



**VALHI**

**2019**

**ANNUAL REPORT**

## VALHI, INC. CORPORATE AND OTHER INFORMATION

### Board of Directors

Thomas E. Barry (a) (b)  
*Emeritus Professor of Marketing at  
Southern Methodist University*

Loretta J. Feehan  
*Chair of Board (non executive)  
Financial Consultant*

Robert D. Graham  
*Vice Chairman, President and  
Chief Executive Officer*

Terri L. Herrington (a)  
*Private Investor*

W. Hayden McIlroy (a) (b)  
*Private Investor*

Mary A. Tidlund (a)  
*Private Investor*

### Board Committees

(a) *Audit Committee*

(b) *Management Development and  
Compensation Committee*

### Corporate Officers

Robert D. Graham  
*Vice Chairman, President and  
Chief Executive Officer*

Kelly D. Luttmer  
*Executive Vice President and  
Chief Tax Officer*

Andrew B. Nace  
*Executive Vice President and General  
Counsel*

Courtney J. Riley  
*Executive Vice President, Environmental  
Affairs*

James W. Brown  
*Senior Vice President and Chief Financial  
Officer*

Steve S. Eaton  
*Vice President, Internal Control*

Jane R. Grimm  
*Vice President and Secretary*

Bryan A. Hanley  
*Vice President and Treasurer*

Janet G. Keckeisen  
*Vice President, Corporate Strategy and  
Investor Relations*

Amy A. Samford  
*Vice President and Controller*

Michael S. Simmons  
*Vice President and Chief Accounting Officer*

John A. Sunny  
*Vice President, Information Technology*

### Management of Subsidiaries

**Kronos Worldwide Inc.**  
Robert D. Graham  
*Vice Chairman, President and  
Chief Executive Officer*

**NL Industries, Inc.**  
Robert D. Graham  
*Vice Chairman and Chief Executive  
Officer*

**CompX International Inc.**  
Scott C. James  
*President and Chief Executive Officer*

**Basic Management, Inc. and  
The LandWell Company**  
T. Mark Paris  
*President and Chief Executive Officer*

### Stock Exchanges

Valhi's common shares are listed on the New York Stock Exchange under the symbol "VHI."

Kronos' common shares are listed on the New York Stock Exchange under the symbol "KRO."

NL's common shares are listed on the New York Stock Exchange under the symbol "NL."

CompX's Class A common shares are listed on the NYSE American under the symbol "CIX."

### Annual Meeting

The 2020 Annual Meeting of Stockholders will be held at the office of the Company, Three Lincoln Centre, 5430 LBJ Freeway, Suite 1700, Dallas, Texas 75240-2620, on the date and time as set forth in the notice of the meeting, proxy statement and form of proxy that will be mailed to stock holders in advance of the meeting

### Form 10-K Report

The Company's Annual Report on Form 10-K for the year ended December 31, 2019, as filed with the Securities and Exchange Commission, is printed as part of this Annual Report. Additional copies are available without charge upon written request to:

Janet G. Keckeisen  
Vice President, Corporate Strategy and  
Investor Relations  
Valhi, Inc.  
Three Lincoln Centre  
5430 LBJ Freeway, Suite 1700  
Dallas, Texas 75240-2620

### Transfer Agent

Computershare acts as transfer agent, registrar and dividend paying agent for the Company's common stock. Communications regarding stockholder accounts, dividends and change of address should be directed to:

Computershare Trust Company, N.A.  
P.O. Box 505000  
Louisville, Kentucky 40233-5000  
(877) 373-6374  
<http://www.computershare.com/investor>

### Visit us on the Web

<http://www.valhi.net>

**UNITED STATES  
SECURITIES AND EXCHANGE COMMISSION  
Washington, D.C. 20549**

**FORM 10-K**

**ANNUAL REPORT PURSUANT TO SECTION 13 OR 15(d)  
OF THE SECURITIES EXCHANGE ACT OF 1934**

For the fiscal year ended December 31, 2019

OR

**TRANSITION REPORT PURSUANT TO SECTION 13 OR 15(d)  
OF THE SECURITIES EXCHANGE ACT OF 1934**

For the transition period from     to

Commission file number 1-5467

**VALHI, INC.**

(Exact name of Registrant as specified in its charter)

**Delaware**  
(State or other jurisdiction of  
Incorporation or organization)

**87-0110150**  
(IRS Employer  
Identification No.)

**5430 LBJ Freeway, Suite 1700,  
Dallas, Texas 75240-2620**

(Address of principal executive offices)

Registrant's telephone number, including area code: (972) 233-1700

Securities registered pursuant to Section 12(b) of the Act:

<u>Title of each class</u>	<u>Trading Symbol(s)</u>	<u>Name of each exchange on which registered</u>
Common stock	VHI	NYSE

**No Securities registered pursuant to Section 12(g) of the Act:**

Indicate by check mark:

If the Registrant is a well-known seasoned issuer, as defined in Rule 405 of the Securities Act. Yes  No

If the Registrant is not required to file reports pursuant to Section 13 or Section 15(d) of the Act. Yes  No

Whether the Registrant (1) has filed all reports required to be filed by Section 13 or 15(d) of the Securities Exchange Act of 1934 during the preceding 12 months (or for such shorter period that the Registrant was required to file such reports), and (2) has been subject to such filing requirements for the past 90 days. Yes  No

Whether the Registrant has submitted electronically every Interactive Data File required to be submitted pursuant to Rule 405 of Regulation S-T (§232.405 of this chapter) during the preceding 12 months (or for such shorter period that the registrant was required to submit such files). Yes  No

Whether the Registrant is a large accelerated filer, an accelerated filer, non-accelerated filer, smaller reporting company or an emerging growth company. See the definitions of "large accelerated filer", "accelerated filer," smaller reporting company," and "emerging growth company" in Rule 12b-2 of the Act.

Large accelerated filer  Accelerated filer

Non-accelerated filer  Smaller reporting company

Emerging growth company

If an emerging growth company, indicate by check mark if the registrant has elected not to use the extended transition period for complying with any new or revised financial accounting standards provided pursuant to Section 13(a) of the Exchange Act.

Whether the Registrant is a shell company (as defined in Rule 12b-2 of the Act). Yes  No .

The aggregate market value of the 28.8 million shares of voting common stock held by nonaffiliates of Valhi, Inc. as of June 28, 2019 (the last business day of the Registrant's most recently-completed second fiscal quarter) approximated \$85.6 million.

Number of shares of the registrant's common stock, \$.01 par value per share, outstanding on March 2, 2020: 339,235,449.

**Documents incorporated by reference**

The information required by Part III is incorporated by reference from the Registrant's definitive proxy statement to be filed with the Commission pursuant to Regulation 14A not later than 120 days after the end of the fiscal year covered by this report.

**Valhi, Inc.**  
(NYSE: VHI)  
December 31, 2019

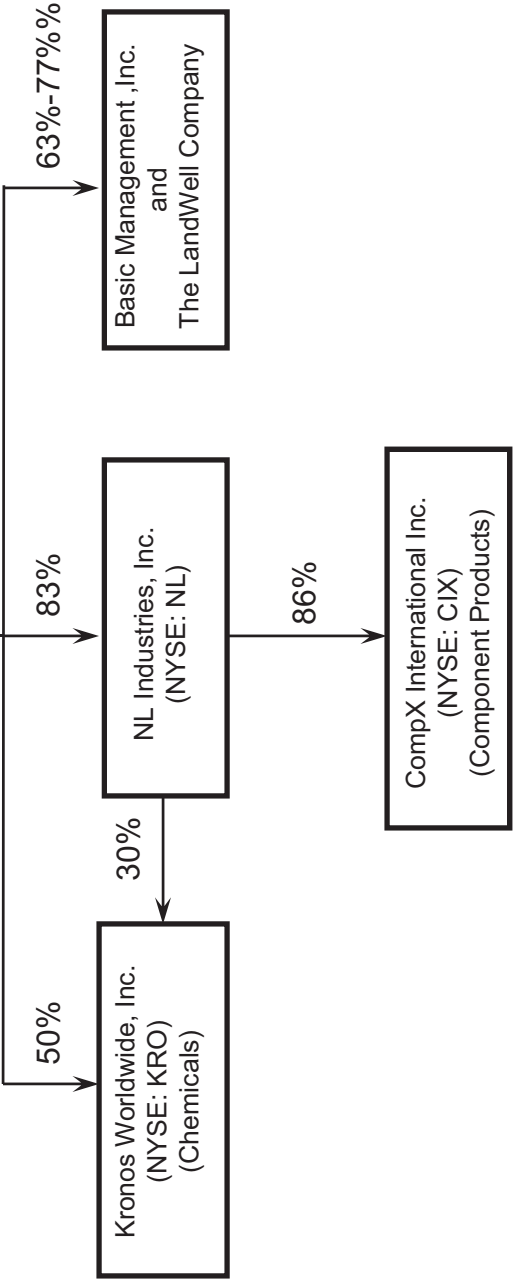

## PART I

### ITEM 1. BUSINESS

Valhi, Inc. (NYSE: VHI) is primarily a holding company. We operate through our wholly-owned and majority-owned subsidiaries, including NL Industries, Inc., Kronos Worldwide, Inc., CompX International Inc., Basic Management, Inc. and The LandWell Company. Kronos (NYSE: KRO), NL (NYSE: NL) and CompX (NYSE American: CIX) each file periodic reports with the U.S. Securities and Exchange Commission (“SEC”).

Our principal executive offices are located at Three Lincoln Center 5430 LBJ Freeway, Suite 1700, Dallas, Texas 75240-2620. Our telephone number is (972) 233-1700. We maintain a website at [www.valhi.net](http://www.valhi.net).

#### Brief History

LLC Corporation, our legal predecessor, was incorporated in Delaware in 1932. We are the successor company of the 1987 merger of LLC Corporation and another entity controlled by Contran Corporation. One of Contran’s wholly-owned subsidiaries held approximately 92% of Valhi’s outstanding common stock at December 31, 2019. As discussed in Note 1 to our Consolidated Financial Statements, Lisa K. Simmons, Serena Simmons Connelly and a trust established for the benefit of Ms. Simmons, Ms. Connelly and their children (the “Family Trust”) may be deemed to control Contran and us.

Key events in our history include:

- 1979—Contran acquires control of LLC;
- 1981—Contran acquires control of our other predecessor company;
- 1982—Contran acquires control of Keystone Consolidated Industries, Inc., a predecessor to CompX;
- 1984—Keystone spins-off an entity that includes what is to become CompX; this entity subsequently merges with LLC;
- 1986—Contran acquires control of NL, which at the time owns 100% of Kronos;
- 1987—LLC and another Contran controlled company merge to form Valhi, our current corporate structure;
- 1995—WCS begins start-up operations;
- 2003—NL completes the spin-off of Kronos through the pro-rata distribution of Kronos shares to its shareholders including us;
- 2004 through 2005—NL distributes Kronos shares to its shareholders, including us, through quarterly dividends;
- 2008—WCS receives a license for the disposal of byproduct material and begins construction of the byproduct facility infrastructure;
- 2009—WCS receives a license for the disposal of Class A, B and C low-level radioactive waste (“LLRW”) and completes construction of the byproduct facility;
- 2010—Kronos completes a secondary offering of its common stock lowering our ownership of Kronos to 80%;
- 2011—WCS begins construction on its Compact and Federal LLRW and mixed LLRW disposal facilities;
- 2012—WCS completes construction of its Compact and Federal LLRW disposal facilities and commences operations at the Compact facility;
- 2012—In December CompX completes the sale of its furniture components business;
- 2013—WCS commences operations at the Federal LLRW facility;
- 2013—In December we purchased an additional ownership interest in and became the majority owner of Basic Management, Inc. and The LandWell Company; both companies are now included in our Consolidated Financial Statements effective December 31, 2013;
- 2015—The first homes in our Cadence planned community were completed by third-party builders and sold to the public; and
- 2018—In January we completed the sale of WCS.

Unless otherwise indicated, references in this report to “we”, “us” or “our” refer to Valhi, Inc. and its subsidiaries, taken as a whole.

## Forward-Looking Statements

This Annual Report on Form 10-K contains forward-looking statements within the meaning of the Private Securities Litigation Reform Act of 1995, as amended. Statements in this Annual Report that are not historical facts are forward-looking in nature and represent management’s beliefs and assumptions based on currently available information. In some cases, you can identify forward-looking statements by the use of words such as “believes,” “intends,” “may,” “should,” “could,” “anticipates,” “expects” or comparable terminology, or by discussions of strategies or trends. Although we believe that the expectations reflected in such forward-looking statements are reasonable, we do not know if these expectations will be correct. Such statements by their nature involve substantial risks and uncertainties that could significantly impact expected results. Actual future results could differ materially from those predicted. The factors that could cause actual future results to differ materially from those described herein are the risks and uncertainties discussed in this Annual Report and those described from time to time in our other filings with the SEC and include, but are not limited to, the following:

- Future supply and demand for our products;
- The extent of the dependence of certain of our businesses on certain market sectors;
- The cyclicity of certain of our businesses (such as Kronos’ TiO<sub>2</sub> operations);
- Customer and producer inventory levels;
- Unexpected or earlier-than-expected industry capacity expansion (such as the TiO<sub>2</sub> industry);
- Changes in raw material and other operating costs (such as ore, zinc, brass, aluminum, steel and energy costs);
- Changes in the availability of raw materials (such as ore);
- General global economic and political conditions that harm the worldwide economy, disrupt our supply chain, increase material costs or reduce demand or perceived demand for TiO<sub>2</sub> and component products (including changes in the level of gross domestic product in various regions of the world, natural disasters, terrorist acts, global conflicts and public health crises such as the coronavirus);
- Competitive products and substitute products;
- Customer and competitor strategies;
- Potential difficulties in integrating future acquisitions;
- Potential difficulties in upgrading or implementing accounting and manufacturing software systems;
- Potential consolidation of our competitors;
- Potential consolidation of our customers;
- The impact of pricing and production decisions;
- Competitive technology positions;
- Our ability to protect or defend intellectual property rights;
- The introduction of trade barriers or trade disputes;
- The ability of our subsidiaries to pay us dividends;
- The impact of current or future government regulations (including employee healthcare benefit related regulations);
- Uncertainties associated with new product development and the development of new product features;
- Fluctuations in currency exchange rates (such as changes in the exchange rate between the U.S. dollar and each of the euro, the Norwegian krone and the Canadian dollar) or possible disruptions to our business resulting from uncertainties associated with the euro or other currencies;
- Operating interruptions (including, but not limited to, labor disputes, leaks, natural disasters, fires, explosions, unscheduled or unplanned downtime, transportation interruptions and cyber-attacks);
- Decisions to sell operating assets other than in the ordinary course of business;

- The timing and amounts of insurance recoveries;
- Our ability to renew, amend, refinance or establish credit facilities;
- Our ability to maintain sufficient liquidity;
- The ultimate outcome of income tax audits, tax settlement initiatives or other tax matters, including future tax reform;
- Our ability to utilize income tax attributes, the benefits of which may or may not have been recognized under the more-likely-than-not recognition criteria;
- Environmental matters (such as those requiring compliance with emission and discharge standards for existing and new facilities, or new developments regarding environmental remediation at sites related to our former operations);
- Government laws and regulations and possible changes therein (such as changes in government regulations which might impose various obligations on former manufacturers of lead pigment and lead-based paint, including NL, with respect to asserted health concerns associated with the use of such products) including new environmental health and safety regulations such as those seeking to limit or classify TiO<sub>2</sub> or its use;
- The ultimate resolution of pending litigation (such as NL's lead pigment and environmental matters);
- Our ability to comply with covenants contained in our revolving bank credit facilities;
- Our ability to complete and comply with the conditions of our licenses and permits;
- Changes in real estate values and construction costs in Henderson, Nevada;
- Water levels in Lake Mead; and
- Possible future litigation.

Should one or more of these risks materialize (or the consequences of such development worsen), or should the underlying assumptions prove incorrect, actual results could differ materially from those currently forecasted or expected. We disclaim any intention or obligation to update or revise any forward-looking statement whether as a result of changes in information, future events or otherwise.

## Segments

We currently have three consolidated reportable operating segments at December 31, 2019:

### **Chemicals**

Kronos Worldwide, Inc.

Our Chemicals Segment is operated through our majority control of Kronos. Kronos is a leading global producer and marketer of value-added titanium dioxide pigments (“TiO<sub>2</sub>”). TiO<sub>2</sub> is used to impart whiteness, brightness, opacity and durability to a wide variety of products, including paints, plastics, paper, fibers and ceramics. Additionally, TiO<sub>2</sub> is a critical component of everyday applications, such as coatings, plastics and paper, as well as many specialty products such as inks, foods and cosmetics.

### **Component Products**

CompX International Inc.

We operate in the component products industry through our majority control of CompX. CompX is a leading manufacturer of security products used in the recreational transportation, postal, office and institutional furniture, cabinetry, tool storage, healthcare and a variety of other industries. CompX also manufactures stainless steel exhaust systems, gauges, throttle controls, wake enhancement systems and trim tabs for the recreational marine industry.

### **Real Estate Management and Development**

Basic Management, Inc. and The LandWell Company

We operate in real estate management and development through our majority control of BMI and LandWell. BMI provides utility services to certain industrial and municipal customers and owns real property in Henderson, Nevada. LandWell is engaged in efforts to develop certain land holdings for commercial, industrial and residential purposes in Henderson, Nevada.

For additional information about our segments and equity investments see “Part II—Item 7. Management’s Discussion and Analysis of Financial Condition and Results of Operations” and Notes 2 and 7 to our Consolidated Financial Statements.

## **CHEMICALS SEGMENT—KRONOS WORLDWIDE, INC.**

### **Business Overview**

Through our majority-controlled subsidiary, Kronos, we are a leading global producer and marketer of value-added titanium dioxide pigments, or TiO<sub>2</sub>, a base industrial product used in a wide range of applications. We, along with our distributors and agents, sell and provide technical services for our products to approximately 4,000 customers in 100 countries with the majority of sales in Europe, North America and the Asia Pacific region. We believe we have developed considerable expertise and efficiency in the manufacture, sale, shipment and service of our products in domestic and international markets.

TiO<sub>2</sub> is a white inorganic pigment used in a wide range of products for its exceptional durability and its ability to impart whiteness, brightness and opacity. TiO<sub>2</sub> is a critical component of everyday applications, such as coatings, plastics and paper, as well as many specialty products such as inks, food and cosmetics. TiO<sub>2</sub> is widely considered to be superior to alternative white pigments in large part due to its hiding power (or opacity), which is the ability to cover or mask other materials effectively and efficiently. TiO<sub>2</sub> is designed, marketed and sold based on specific end-use applications.

TiO<sub>2</sub> is the largest commercially used whitening pigment because it has a high refractive rating, giving it more hiding power than any other commercially produced white pigment. In addition, TiO<sub>2</sub> has excellent resistance to interaction with other chemicals, good thermal stability and resistance to ultraviolet degradation. Although there are other white pigments on the market, we believe there are no effective substitutes for TiO<sub>2</sub> because no other white pigment has the physical properties for achieving comparable opacity and brightness or can be incorporated in as cost-effective a manner. Pigment extenders such as kaolin clays, calcium carbonate and polymeric opacifiers are used together with TiO<sub>2</sub> in a number of end-use markets. However, these products are not able to duplicate the opacity performance characteristics of TiO<sub>2</sub> and we believe these products are unlikely to have a significant impact on the use of TiO<sub>2</sub>.

TiO<sub>2</sub> is considered a “quality-of-life” product. Demand for TiO<sub>2</sub> has generally been driven by worldwide gross domestic product and has generally increased with rising standards of living in various regions of the world. According to industry estimates,



TiO<sub>2</sub> consumption has grown at a compound annual growth rate of approximately 3% since 1990. Per capita consumption of TiO<sub>2</sub> in Western Europe and North America far exceeds that in other areas of the world, and these regions are expected to continue to be the largest consumers of TiO<sub>2</sub> on a per capita basis for the foreseeable future. We believe that Western Europe and North America currently each account for approximately 17% of global TiO<sub>2</sub> consumption. Markets for TiO<sub>2</sub> are generally increasing in South America, Eastern Europe, the Asia Pacific region and China and we believe these are significant markets where we expect continued growth as economies in these regions continue to develop and quality-of-life products, including TiO<sub>2</sub>, experience greater demand.

### **Products and end-use markets**

Including its predecessors, Kronos has produced and marketed TiO<sub>2</sub> in North America and Europe, our primary markets, for over 100 years. We believe we are the largest producer of TiO<sub>2</sub> in Europe with 46% of our 2019 sales volumes attributable to markets in Europe. The table below shows our market share for our significant markets, Europe and North America, for the last three years.

	<u>2017</u>	<u>2018</u>	<u>2019</u>
Europe	17%	13%	18%
North America	18%	17%	19%

We believe we are the leading seller of TiO<sub>2</sub> in several countries, including Germany, with an estimated 9% share of worldwide TiO<sub>2</sub> sales volume in 2019. Overall, we are one of the top five producers of TiO<sub>2</sub> in the world.

We offer our customers a broad portfolio of products that include over 40 different TiO<sub>2</sub> pigment grades under the *KRONOS*<sup>®</sup> trademark, which provide a variety of performance properties to meet customers' specific requirements. Our major customers include domestic and international paint, plastics, decorative laminate and paper manufacturers. We ship TiO<sub>2</sub> to our customers in either a powder or slurry form via rail, truck and/or ocean carrier. Sales of our core TiO<sub>2</sub> pigments represented approximately 94% of our Chemicals Segment's net sales in 2019. We and our agents and distributors primarily sell our products in three major end-use markets: coatings, plastics and paper.

The following tables show our approximate TiO<sub>2</sub> sales volume by geographic region and end-use for the year ended December 31, 2019:

<u>Sales volume percentages by geographic region</u>		<u>Sales volume percentages by end-use</u>	
Europe	46%	Coatings	57%
North America	34%	Plastics	28%
Asia Pacific	10%	Paper	5%
Rest of World	10%	Other	10%

Some of the principal applications for our products include the following:

*TiO<sub>2</sub> for coatings* – Our Chemicals Segment's TiO<sub>2</sub> is used to provide opacity, durability, tinting strength and brightness in industrial coatings, as well as coatings for commercial and residential interiors and exteriors, automobiles, aircraft, machines, appliances, traffic paint and other special purpose coatings. The amount of TiO<sub>2</sub> used in coatings varies widely depending on the opacity, color and quality desired. In general, the higher the opacity requirement of the coating, the greater the TiO<sub>2</sub> content.

*TiO<sub>2</sub> for plastics* – Our Chemicals Segment produces TiO<sub>2</sub> pigments that improve the optical and physical properties of plastics, including whiteness and opacity. TiO<sub>2</sub> is used to provide opacity to items such as containers and packaging materials, and vinyl products such as windows, door profiles and siding. TiO<sub>2</sub> also generally provides hiding power, neutral undertone, brightness and surface durability for housewares, appliances, toys, computer cases and food packages. TiO<sub>2</sub>'s high brightness along with its opacity, is used in some engineering plastics to help mask their undesirable natural color. TiO<sub>2</sub> is also used in masterbatch, which is a concentrate of TiO<sub>2</sub> and other additives and is one of the largest uses for TiO<sub>2</sub> in the plastics end-use market. In masterbatch, the TiO<sub>2</sub> is dispersed at high concentrations into a plastic resin and is then used by manufacturers of plastic containers, bottles, packaging and agricultural films.

*TiO<sub>2</sub> for paper* – Our Chemicals Segment's TiO<sub>2</sub> is used in the production of several types of paper, including laminate (decorative) paper, filled paper and coated paper to provide whiteness, brightness, opacity and color stability. Although we sell our TiO<sub>2</sub> to all segments of the paper end-use market, our primary focus is on the TiO<sub>2</sub> grades used in paper laminates, where several layers of paper are laminated together using melamine resin under high temperature and pressure. The top layer of paper contains TiO<sub>2</sub> and plastic resin and is the layer that is printed with decorative patterns. Paper laminates are used to replace materials such as

wood and tile for such applications as counter tops, furniture and wallboard.  $\text{TiO}_2$  is beneficial in these applications because it assists in preventing the material from fading or changing color after prolonged exposure to sunlight and other weathering agents.

*TiO<sub>2</sub> for other applications* – Our Chemicals Segment produces  $\text{TiO}_2$  to improve the opacity and hiding power of printing inks.  $\text{TiO}_2$  allows inks to achieve very high print quality while not interfering with the technical requirements of printing machinery, including low abrasion, high printing speed and high temperatures. Our  $\text{TiO}_2$  is also used in textile applications where  $\text{TiO}_2$  functions as an opacifying and delustering agent. In man-made fibers such as rayon and polyester,  $\text{TiO}_2$  corrects an otherwise undesirable glossy and translucent appearance. Without the presence of  $\text{TiO}_2$ , these materials would be unsuitable for use in many textile applications.

Our Chemicals Segment produces high purity sulfate process anatase  $\text{TiO}_2$  used to provide opacity, whiteness and brightness in a variety of cosmetic and personal care products, such as skin cream, lipstick, eye shadow and toothpaste. Our  $\text{TiO}_2$  is also found in food products, such as candy and confectionaries, and in pet foods where it is used to obtain uniformity of color and appearance. In pharmaceuticals, our  $\text{TiO}_2$  is used commonly as a colorant in tablet and capsule coatings as well as in liquid medicines to provide uniformity of color and appearance. KRONOS® purified anatase grades meet the applicable requirements of the CTFA (Cosmetics, Toiletries and Fragrances Association), USP and BP (United States Pharmacopoeia and British Pharmacopoeia) and the FDA (United States Food and Drug Administration).

Our Chemicals Segment's  $\text{TiO}_2$  business is enhanced by the following three complementary businesses, which comprised approximately 6% of our Chemicals Segment's net sales in 2019:

- Kronos owns and operates two ilmenite mines in Norway pursuant to a governmental concession with an unlimited term. Ilmenite is a raw material used directly as a feedstock by some sulfate-process  $\text{TiO}_2$  plants. We supply ilmenite to our sulfate plants in Europe. We also sell ilmenite ore to third parties, some of whom are our competitors, and we sell an ilmenite-based specialty product to the oil and gas industry. The mines have estimated ilmenite reserves that are expected to last at least 50 years.
- Kronos manufactures and sells iron-based chemicals, which are co-products and processed co-products of sulfate and chloride process  $\text{TiO}_2$  pigment production. These co-product chemicals are marketed through our Ecochem division and are primarily used as treatment and conditioning agents for industrial effluents and municipal wastewater as well as in the manufacture of iron pigments, cement and agricultural products.
- Kronos manufactures and sells titanium oxychloride and titanyl sulfate, which are side-stream specialty products from the production of  $\text{TiO}_2$ . Titanium oxychloride is used in specialty applications in the formulation of pearlescent pigments, production of electroceramic capacitors for cell phones and other electronic devices. Titanyl sulfate products are used in pearlescent pigments, natural gas pipe and other specialty applications.

### ***Manufacturing, operations and properties***

Our Chemicals Segment produces  $\text{TiO}_2$  in two crystalline forms: rutile and anatase. Rutile  $\text{TiO}_2$  is manufactured using both a chloride production process and a sulfate production process, whereas anatase  $\text{TiO}_2$  is only produced using a sulfate production process. Manufacturers of many end-use applications can use either form, especially during periods of tight supply for  $\text{TiO}_2$ . The chloride process is the preferred form for use in coatings and plastics, the two largest end-use markets. Due to environmental factors and customer considerations, the proportion of  $\text{TiO}_2$  industry sales represented by chloride process pigments has remained stable relative to sulfate process pigments, and in 2019, chloride process production facilities represented approximately 45% of industry capacity. The sulfate process is preferred for use in selected paper products, ceramics, rubber tires, man-made fibers, food products, pharmaceuticals and cosmetics. Once an intermediate  $\text{TiO}_2$  pigment has been produced by either the chloride or sulfate process, it is “finished” into products with specific performance characteristics for particular end-use applications through proprietary processes involving various chemical surface treatments and intensive micronizing (milling).

- *Chloride process* – The chloride process is a continuous process in which chlorine is used to extract rutile  $\text{TiO}_2$ . The chloride process produces less waste than the sulfate process because much of the chlorine is recycled and feedstock bearing higher titanium content is used. The chloride process also has lower energy requirements and is less labor-intensive than the sulfate process, although the chloride process requires a higher-skilled labor force. The chloride process produces an intermediate base pigment with a wide range of properties.
- *Sulfate process* – The sulfate process is a batch process in which sulfuric acid is used to extract the  $\text{TiO}_2$  from ilmenite or titanium slag. After separation from the impurities in the ore (mainly iron), the  $\text{TiO}_2$  is precipitated and calcined to form an intermediate base pigment ready for sale or can be upgraded through finishing treatments.

Our Chemicals Segment produced 546,000 metric tons of  $\text{TiO}_2$  in 2019, up from the 536,000 metric tons we produced in 2018. Our production volumes include our share of the output produced by our  $\text{TiO}_2$  manufacturing joint venture discussed below in

“TiO<sub>2</sub> manufacturing joint venture.” Our average production capacity utilization rates were at full practical capacity in 2017, 95% in 2018 and 98% in 2019. Our TiO<sub>2</sub> production rates in 2018 were impacted by maintenance activities at certain facilities and by the first quarter implementation of a productivity-enhancing improvement project at our Belgian facility.

Our Chemicals Segment operates facilities throughout North America and Europe, including the only sulfate process plant in North America and four TiO<sub>2</sub> plants in Europe (one in each of Leverkusen, Germany; Nordenham, Germany; Langerbrugge, Belgium; and Fredrikstad, Norway). In North America, we have a TiO<sub>2</sub> plant in Varennes, Quebec, Canada and, through the manufacturing joint venture described below in “TiO<sub>2</sub> manufacturing joint venture,” a 50% interest in a TiO<sub>2</sub> plant in Lake Charles, Louisiana.

Our Chemicals Segment’s production capacity has increased by approximately 5% over the past ten years due to debottlenecking programs, incurring moderate capital expenditures. We expect to operate our TiO<sub>2</sub> plants at near full practical capacity levels in 2020.

The following table presents the division of our Chemicals Segment’s expected 2020 manufacturing capacity by plant location and type of manufacturing process:

Facility	Description	% of capacity by TiO <sub>2</sub> manufacturing process	
		Chloride	Sulfate
Leverkusen, Germany (1)	TiO <sub>2</sub> production, chloride and sulfate process, co-products	31%	2%
Nordenham, Germany	TiO <sub>2</sub> production, sulfate process, co-products	-	11
Langerbrugge, Belgium	TiO <sub>2</sub> production, chloride process, co-products, titanium chemicals products	16	-
Fredrikstad, Norway (2)	TiO <sub>2</sub> production, sulfate process, co-products	-	7
Varennes, Canada	TiO <sub>2</sub> production, chloride and sulfate process, slurry facility, titanium chemicals products	16	3
Lake Charles, LA, US (3)	TiO <sub>2</sub> production, chloride process	14	-
Total		<u>77%</u>	<u>23%</u>

- (1) The Leverkusen facility is located within an extensive manufacturing complex owned by Bayer AG. Our Chemicals Segment owns the Leverkusen facility, which represents about one-third of our current TiO<sub>2</sub> production capacity, but we lease the land under the facility from Bayer under a long-term agreement which expires in 2050. Lease payments are periodically negotiated with Bayer for periods of at least two years at a time. A majority-owned subsidiary of Bayer provides some raw materials including chlorine, auxiliary and operating materials, utilities and services necessary to operate the Leverkusen facility under separate supplies and services agreements. In conjunction with our long-term strategy to increase chloride process production, in late 2019 we decided to phase-out sulfate production at the Leverkusen facility by the end of 2020.
- (2) The Fredrikstad facility is located on public land and is leased until 2063.
- (3) Our Chemicals Segment operates the Lake Charles facility in a joint venture with Venator Investments LLC (Venator Investments), a wholly-owned subsidiary of Venator Group, of which Venator Materials PLC (Venator) owns 100% and the amount indicated in the table above represents the share of TiO<sub>2</sub> produced by the joint venture to which we are entitled. See Note 7 to our Consolidated Financial Statements and “TiO<sub>2</sub> manufacturing joint venture.” The joint venture owns the land and the facility.

Kronos owns the land underlying all of its principal production facilities unless otherwise indicated in the table above.

Kronos also operates two ilmenite mines in Norway pursuant to a governmental concession with an unlimited term. In addition, Kronos operates a rutile slurry manufacturing plant near Lake Charles, Louisiana, which converts dry pigment primarily manufactured for us at the Lake Charles TiO<sub>2</sub> facility into a slurry form that is then shipped to customers.

Kronos has corporate and administrative offices located in the U.S., Germany, Norway, Canada, Belgium, France and the United Kingdom and various sales offices located in North America.

### ***TiO<sub>2</sub> manufacturing joint venture***

Kronos Louisiana, Inc., one of our subsidiaries, and Venator Investments each own a 50% interest in a manufacturing joint venture, Louisiana Pigment Company, L.P. (LPC), which owns and operates a chloride-process TiO<sub>2</sub> plant located near Lake Charles, Louisiana. We and Venator share production from the plant equally pursuant to separate offtake agreements, unless we and Venator otherwise agree.

A supervisory committee directs the business and affairs of the joint venture, including production and output decisions. This committee is composed of four members, two of whom we appoint and two of whom Venator appoints. Two general managers manage the operations of the joint venture acting under the direction of the supervisory committee. We appoint one general manager and Venator appoints the other.

LPC is not consolidated in our financial statements, because we do not control it. We account for our interest in the joint venture by the equity method. The joint venture operates on a break-even basis and therefore we do not have any equity in earnings of the joint venture. We are required to purchase one half of the TiO<sub>2</sub> produced by the joint venture. All costs and capital expenditures are shared equally with Venator with the exception of feedstock (purchased natural rutile ore or chlorine slag) and packaging costs for the pigment grades produced. Our share of net costs is reported as cost of sales as the TiO<sub>2</sub> is sold. See Notes 7 and 18 to our Consolidated Financial Statements.

### ***Raw materials***

The primary raw materials used in chloride process TiO<sub>2</sub> are titanium-containing feedstock (purchased natural rutile ore or chlorine slag), chlorine and coke. Chlorine is available from a number of suppliers, while petroleum coke is available from a limited number of suppliers. Titanium-containing feedstock suitable for use in the chloride process is available from a limited but increasing number of suppliers principally in Australia, South Africa, Canada, India and the United States. We purchase chloride process grade slag from Rio Tinto Iron and Titanium Limited under a long-term supply contract which automatically renewed at the end of 2018 and extends through December 31, 2020. The contract automatically renews bi-annually, but can be terminated if written notice is given at least twelve months prior to the current contract end date. We also purchase upgraded slag from Rio Tinto Iron and Titanium Limited under a long-term supply contract that expires at the end of 2021. We purchase natural rutile ore primarily from Sierra Rutile Limited under a contract that expires in 2022 and Base Titanium Limited under a contract that expires at the end of 2022. In the past we have been, and we expect that we will continue to be, successful in obtaining short-term and long-term extensions to these and other existing supply contracts prior to their expiration. We expect the raw materials purchased under these contracts, and contracts that we may enter into, will meet our chloride process feedstock requirements over the next several years.

The primary raw materials used in sulfate process TiO<sub>2</sub> are titanium-containing feedstock, primarily ilmenite or purchased sulfate grade slag and sulfuric acid. Sulfuric acid is available from a number of suppliers. Titanium-containing feedstock suitable for use in the sulfate process is available from a limited number of suppliers principally in Norway, Canada, Australia, India and South Africa. As one of the few vertically-integrated producers of sulfate process TiO<sub>2</sub>, we operate two rock ilmenite mines in Norway, which provided all of the feedstock for our European sulfate process TiO<sub>2</sub> plants in 2019. We expect ilmenite production from our mines to meet our European sulfate process feedstock requirements for the foreseeable future. For our Canadian sulfate process plant, we purchase sulfate grade slag primarily from Rio Tinto Fer et Titane Inc. under a supply contract that renews annually, subject to termination upon twelve months written notice. We expect the raw materials purchased under these contracts, and contracts that we may enter into, to meet our sulfate process feedstock requirements over the next several years.

Many of our Chemicals Segment's raw material contracts contain fixed quantities we are required to purchase, or specify a range of quantities within which we are required to purchase. The pricing under these agreements is generally negotiated quarterly or semi-annually.

The following table summarizes our raw materials purchased or mined in 2019.

<b><u>Production process/raw material</u></b>	<b><u>Raw materials procured or mined (In thousands of metric tons)</u></b>
Chloride process plants -	
Purchased slag or rutile ore	523
Sulfate process plants:	
Ilmenite ore mined and used internally	300
Purchased slag	24

## ***Sales and marketing***

Our Chemicals Segment's marketing strategy is aimed at developing and maintaining strong relationships with new and existing customers. Because TiO<sub>2</sub> represents a significant input cost for our customers, the purchasing decisions are often made by our customers' senior management. We work to maintain close relationships with the key decision makers through in-depth and frequent in-person meetings. We endeavor to extend these commercial and technical relationships to multiple levels within our customers' organization using our direct sales force and technical service group to accomplish this objective. We believe this has helped build customer loyalty to Kronos and strengthened our competitive position. Close cooperation and strong customer relationships enable us to stay closely attuned to trends in our customers' businesses. Where appropriate, we work in conjunction with our customers to solve formulation or application problems by modifying specific product properties or developing new pigment grades. We also focus our sales and marketing efforts on those geographic and end-use market segments where we believe we can realize higher selling prices. This focus includes continuously reviewing and optimizing our customer and product portfolios.

Our Chemicals Segment also works directly with our customers to monitor the success of our products in their end-use applications, evaluate the need for improvements in our product and process technology and identify opportunities to develop new product solutions for our customers. Our marketing staff closely coordinates with our sales force and technical specialists to ensure the needs of our customers are met, and to help develop and commercialize new grades where appropriate.

Kronos sells a majority of our products through our direct sales force operating in Europe and North America. We also utilize sales agents and distributors who are authorized to sell our products in specific geographic areas. In Europe, our sales efforts are conducted primarily through our direct sales force and our sales agents. Our agents do not sell any TiO<sub>2</sub> products other than KRONOS® brand products. In North America, our sales are made primarily through our direct sales force and supported by a network of distributors. In export markets, where we have increased our marketing efforts over the last several years, our sales are made through our direct sales force, sales agents and distributors. In addition to our direct sales force and sales agents, many of our sales agents also act as distributors to service our customers in all regions. We offer customer and technical service to customers who purchase our products through distributors as well as to our larger customers serviced by our direct sales force.

Kronos sells to a diverse customer base with only one customer representing 10% or more of our Chemicals Segment's net sales in 2019 (Behr Process Corporation – 10%). Our largest ten customers accounted for approximately 36% of our Chemicals Segment's net sales in 2019.

Neither our Chemicals Segment's business as a whole nor any of its principal product groups is seasonal to any significant extent. However, TiO<sub>2</sub> sales are generally higher in the second and third quarters of the year, due in part to the increase in coatings production in the spring to meet demand during the spring and summer painting seasons. With certain exceptions, we have historically operated our production facilities at near full capacity rates throughout the entire year, which among other things helps to minimize our per-unit production costs. As a result, we normally will build inventories during the first and fourth quarters of each year in order to maximize our product availability during the higher demand periods normally experienced in the second and third quarters.

## ***Competition***

The TiO<sub>2</sub> industry is highly competitive. We compete primarily on the basis of price, product quality, technical service and the availability of high performance pigment grades. Since TiO<sub>2</sub> is not a traded commodity, its pricing is largely a product of negotiation between suppliers and their respective customers. Price and availability are the most significant competitive factors along with quality and customer service for the majority of our product grades. Increasingly, we are focused on providing pigments that are differentiated to meet specific customer requests and specialty grades that are differentiated from our competitors' products. During 2019, we had an estimated 9% share of worldwide TiO<sub>2</sub> sales volume, and based on sales volume, we believe we are the leading seller of TiO<sub>2</sub> in several countries, including Germany.

Our Chemicals Segment's principal competitors are The Chemours Company, Tronox Incorporated, Lomon Billions and Venator Materials PLC. The top five TiO<sub>2</sub> producers (i.e. we and our four principal competitors) account for approximately 52% of the world's production capacity.

The following chart shows our estimate of worldwide production capacity in 2019:

<b>Worldwide production capacity - 2019</b>	
Chemours	16%
Tronox	12%
Lomon Billions	9%
Venator	8%
Kronos	7%
Other	48%

Chemours has over one-half of total North American TiO<sub>2</sub> production capacity and is our principal North American competitor. In the second quarter of 2019, Tronox acquired certain of the TiO<sub>2</sub> assets of Cristal Global. In 2018, Lomon Billions announced construction plans for an additional 200,000 tons of chloride capacity, a portion of which came on line in 2019. The remainder is scheduled to come on line in 2020.

Over the past ten years, we and our competitors increased industry capacity through debottlenecking projects, which in part compensated for the shut-down of various TiO<sub>2</sub> plants throughout the world. Although overall industry demand is expected to increase in 2020, we do not expect any significant efforts will be undertaken by us or our principal competitors to further increase capacity for the foreseeable future, other than through debottlenecking projects and the Lomon Billions expansion mentioned above. If actual developments differ from our expectations, the TiO<sub>2</sub> industry's and our performance could be unfavorably affected.

The TiO<sub>2</sub> industry is characterized by high barriers to entry consisting of high capital costs, proprietary technology and significant lead times required to construct new facilities or to expand existing capacity. We believe it is unlikely any new TiO<sub>2</sub> plants will be constructed in Europe or North America in the foreseeable future.

### ***Research and development***

Kronos employs scientists, chemists, process engineers and technicians who are engaged in research and development, process technology and quality assurance activities in Leverkusen, Germany. These individuals have the responsibility for improving our chloride and sulfate production processes, improving product quality and strengthening our competitive position by developing new products and applications. Our Chemicals Segment's expenditures for these activities were approximately \$18 million in 2017, \$16 million in 2018 and \$17 million in 2019. Our Chemicals Segment expects to spend approximately \$17 million on research and development in 2020.

We continually seek to improve the quality of our grades and have been successful at developing new grades for existing and new applications to meet the needs of our customers and increase product life cycles. Since the beginning of 2015, we have added ten new grades for pigments and other applications.

### ***Patents, trademarks, trade secrets and other intellectual property rights***

Kronos has a comprehensive intellectual property protection strategy that includes obtaining, maintaining and enforcing our patents, primarily in the United States, Canada and Europe. We also protect our trademark and trade secret rights and have entered into license agreements with third parties concerning various intellectual property matters. We have also from time to time been involved in disputes over intellectual property.

*Patents* – Kronos has obtained patents and has numerous patent applications pending that cover our products and the technology used in the manufacture of our products. Our patent strategy is important to us and our continuing business activities. In addition to maintaining our patent portfolio, we seek patent protection for our technical developments, principally in the United States, Canada and Europe. U.S. patents are generally in effect for 20 years from the date of filing. Our U.S. patent portfolio includes patents having remaining terms ranging from four years to 20 years.

*Trademarks and trade secrets* – Our Chemicals Segment's trademarks, including KRONOS®, are covered by issued and/or pending registrations, including in Canada and the United States. We protect the trademarks that we use in connection with the products we manufacture and sell and have developed goodwill in connection with our long-term use of our trademarks. We conduct research activities in secret and we protect the confidentiality of our trade secrets through reasonable measures, including confidentiality agreements and security procedures, including data security. We rely upon unpatented proprietary knowledge and continuing technological innovation and other trade secrets to develop and maintain our competitive position. Our proprietary chloride production process is an important part of our technology and our business could be harmed if we fail to maintain confidentiality of our trade secrets used in this technology.

## **Employees**

As of December 31, 2019, Kronos employed the following number of people:

Europe	1,805
Canada	340
United States (1)	55
Total	<u>2,200</u>

(1) Excludes employees of our LPC joint venture.

Certain employees at each of our production facilities are organized by labor unions. In Europe, our union employees are covered by master collective bargaining agreements for the chemical industry that are generally renewed annually. In Canada, our union employees are covered by a collective bargaining agreement that expires in June 2021. At December 31, 2019, approximately 86% of our Chemicals Segment's worldwide workforce is organized under collective bargaining agreements. It is possible that there could be future work stoppages or other labor disruptions that could materially and adversely affect our business, results of operations, financial position or liquidity.

### ***Regulatory and environmental matters***

Our Chemicals Segment's operations and properties are governed by various environmental laws and regulations which are complex, change frequently and have tended to become stricter over time. These environmental laws govern, among other things, the generation, storage, handling, use and transportation of hazardous materials; the emission and discharge of hazardous materials into the ground, air or water; and the health and safety of our employees. Certain of our operations are, or have been, engaged in the generation, storage, handling, manufacture or use of substances or compounds that may be considered toxic or hazardous within the meaning of applicable environmental laws and regulations. As with other companies engaged in similar businesses, certain of our past and current operations and products have the potential to cause environmental or other damage. We have implemented and continue to implement various policies and programs in an effort to minimize these risks. Our policy is to comply with applicable environmental laws and regulations at all our facilities and to strive to improve our environmental performance and overall sustainability. We recently updated our Kronos Sustainability Report (available on Kronos' website at [www.kronostio2.com](http://www.kronostio2.com)), which highlights our focus on sustainability of our manufacturing operations, as well as our environmental, social and governance strategy. It is possible that future developments, such as stricter requirements in environmental laws and enforcement policies, could adversely affect our operations, including production, handling, use, storage, transportation, sale or disposal of hazardous or toxic substances or require us to make capital and other expenditures to comply, and could adversely affect our consolidated financial position and results of operations or liquidity.

Our Chemicals Segment's U.S. manufacturing operations are governed by federal, state and local environmental and worker health and safety laws and regulations. These include the Resource Conservation and Recovery Act, or RCRA, the Occupational Safety and Health Act, the Clean Air Act, the Clean Water Act, the Safe Drinking Water Act, the Toxic Substances Control Act and the Comprehensive Environmental Response, Compensation and Liability Act, as amended by the Superfund Amendments and Reauthorization Act, or CERCLA, as well as the state counterparts of these statutes. Some of these laws hold current or previous owners or operators of real property liable for the costs of cleaning up contamination, even if these owners or operators did not know of, and were not responsible for, such contamination. These laws also assess liability on any person who arranges for the disposal or treatment of hazardous substances, regardless of whether the affected site is owned or operated by such person. Although we have not incurred and do not currently anticipate any material liabilities in connection with such environmental laws, we may be required to make expenditures for environmental remediation in the future.

While the laws regulating operations of industrial facilities in Europe vary from country to country, a common regulatory framework is provided by the European Union, or the EU. Germany and Belgium are members of the EU and follow its initiatives. Norway is not a member but generally patterns its environmental regulatory actions after those of the EU.

At our Chemicals Segment's sulfate plant facilities in Germany, we recycle spent sulfuric acid either through contracts with third parties or at our own facilities. In addition, at our German locations we have a contract with a third-party to treat certain sulfate-process effluents. At our Norwegian plant, we ship spent acid to a third-party location where it is used as a neutralization agent. These contracts may be terminated by either party after giving three or four years advance notice, depending on the contract.

From time to time, our facilities may be subject to environmental regulatory enforcement under U.S. and non-U.S. statutes. Typically we establish compliance programs to resolve these matters. Occasionally, we may pay penalties. To date, such penalties have not involved amounts having a material adverse effect on our consolidated financial position, results of operations or liquidity. We believe all of our facilities are in substantial compliance with applicable environmental laws.

From time to time, new environmental, health and safety regulations are passed or proposed in the countries in which we operate or sell our products, seeking to regulate our operations or to restrict, limit or classify TiO<sub>2</sub>. We believe we are in substantial compliance with laws applicable to the regulation of TiO<sub>2</sub>. However, increased regulatory scrutiny could affect consumer perception of TiO<sub>2</sub> or limit the marketability and demand for TiO<sub>2</sub> or products containing TiO<sub>2</sub> and increase our regulatory and compliance costs.

On February 18, 2020, the European Union published the regulation classifying TiO<sub>2</sub> powder and powder mixtures containing TiO<sub>2</sub> as a suspected carcinogen via inhalation under its EU Regulation No. 1272/2008 on classification, labeling and packing of substances and mixtures. The regulation will enter into force on October 1, 2021 at which time hazard labels will be required on certain TiO<sub>2</sub> powder products and certain powder mixtures containing TiO<sub>2</sub> in the EU.

This classification of TiO<sub>2</sub> is based on scientifically questioned animal test data. Separate studies of TiO<sub>2</sub> workers conducted by the TiO<sub>2</sub> industry have shown no TiO<sub>2</sub> specific links to cancer. We intend to comply with the new requirements including working with customers and other stakeholders on compliance matters as appropriate.

Our Chemicals Segment's capital expenditures related to ongoing environmental compliance, protection and improvement programs, including capital expenditures which are primarily focused on increasing operating efficiency but also result in improved environmental protection such as lower emissions from our manufacturing facilities, were \$20.0 million in 2019 and are currently expected to be approximately \$25 million in 2020.

## COMPONENT PRODUCTS SEGMENT—COMPX INTERNATIONAL INC.

### *Business overview*

Through our majority-controlled subsidiary, CompX, we are a leading manufacturer of security products including mechanical and electrical cabinet locks and other locking mechanisms used in recreational transportation, postal, office and institutional furniture, cabinetry, tool storage and healthcare applications. We also manufacture stainless steel exhaust systems, gauges, throttle controls, wake enhancement systems and trim tabs for the recreational marine and other industries. We continuously seek to diversify into new markets and identify new applications and features for our products, which we believe provide a greater potential for higher rates of earnings growth as well as diversification of risk.

### *Manufacturing, operations and products*

*Security Products.* CompX's security products reporting unit manufactures mechanical and electrical cabinet locks and other locking mechanisms used in a variety of applications including ignition systems, mailboxes, file cabinets, desk drawers, tool storage cabinets, high security medical cabinetry, electronic circuit panels, storage compartments, gas station security, vending and cash containment machines. Our security products reporting unit has one manufacturing facility in Mauldin, South Carolina and one in Grayslake, Illinois which is shared with our marine components reporting unit. We believe we are a North American market leader in the manufacture and sale of cabinet locks and other locking mechanisms. These products include:

- disc tumbler locks which provide moderate security and generally represent the lowest cost lock to produce;
- pin tumbler locking mechanisms which are more costly to produce and are used in applications requiring higher levels of security, including *KeSet*<sup>®</sup> and *System 64*<sup>®</sup> (which each allow the user to change the keying on a single lock 64 times without removing the lock from its enclosure), *TuBar*<sup>®</sup> and *Turbine*<sup>™</sup>; and
- our innovative *CompX eLock*<sup>®</sup> and *StealthLock*<sup>®</sup> electronic locks which provide stand-alone or networked security and audit trail capability for drug storage and other valuables through the use of a proximity card, magnetic stripe, radio frequency or other keypad credential.

A substantial portion of Security Products' sales consist of products with specialized adaptations to an individual customer's specifications, some of which are listed above. We also have a standardized product line suitable for many customers, which is offered through a North American distribution network to locksmith and smaller original equipment manufacturer distributors via our *STOCK LOCKS*<sup>®</sup> distribution program.

*Marine Components.* CompX's marine components reporting unit manufactures and distributes stainless steel exhaust components, gauges, throttle controls, wake enhancement systems, trim tabs and related hardware and accessories primarily for performance and ski/wakeboard boats. Our marine components reporting unit has a facility in Neenah, Wisconsin and a facility in Grayslake, Illinois which is shared with our security products reporting unit. Our specialty marine component products are high precision components designed to operate within tight tolerances in the highly demanding marine environment. These products include:

- original equipment and aftermarket stainless steel exhaust headers, exhaust pipes, mufflers and other exhaust components;



- high performance gauges such as GPS speedometers and tachometers;
- mechanical and electronic controls and throttles;
- wake enhancement devices, trim tabs, steering wheels, and billet aluminum accessories; and
- dash panels, LED indicators, wire harnesses and other accessories.

Our Component Products Segment operated three principal operating facilities at December 31, 2019 as shown below.

<u>Facility Name</u>	<u>Reporting Unit</u>	<u>Location</u>	<u>Size (square feet)</u>
<b>Owned Facilities:</b>			
National <sup>(1)</sup>	SP	Mauldin, SC	198,000
Grayslake <sup>(1)</sup>	SP/MC	Grayslake, IL	133,000
Custom <sup>(1)</sup>	MC	Neenah, WI	95,000

- <sup>(1)</sup> ISO-9001 registered facilities  
 SP- Security Products  
 MC- Marine Components

### ***Raw materials***

Our Component Products Segment's primary raw materials are:

- Security Products - zinc and brass (for the manufacture of locking mechanisms).
- Marine Components - stainless steel (for the manufacture of exhaust headers and pipes and wake enhancement systems), aluminum (for the manufacture of throttles and trim tabs) and other components.

These raw materials are purchased from several suppliers, are readily available from numerous sources and accounted for approximately 13% of our Component Products Segment's total cost of sales for 2019. Total material costs, including purchased components, represented approximately 45% of our Component Products Segment's cost of sales in 2019.

Our Component Products Segment occasionally enters into short-term commodity-related raw material supply arrangements to mitigate the impact of future price increases in commodity-related raw materials, including zinc, brass and stainless steel. These arrangements generally provide for stated unit prices based upon specified purchase volumes, which help us to stabilize our commodity-related raw material costs to a certain extent. During 2018, markets for the primary commodity-related raw materials used in the manufacture of our locking mechanisms, primarily zinc and brass, generally strengthened, but these markets moderated at the end of 2018 and remained relatively stable through 2019. Over that same period, the market for stainless steel, the primary raw material used for the manufacture of marine exhaust headers and pipes and wake enhancement systems, remained relatively stable. While we expect the markets for our primary commodity-related raw materials to remain stable during 2020, we recognize that economic conditions could introduce renewed volatility on these and other manufacturing materials. When purchased on the spot market, each of these raw materials may be subject to sudden and unanticipated price increases. When possible, we seek to mitigate the impact of fluctuations in these raw material costs on our margins through improvements in production efficiencies or other operating cost reductions. In the event we are unable to offset raw material cost increases with other cost reductions, it may be difficult to recover those cost increases through increased product selling prices or raw material surcharges due to the competitive nature of the markets served by our products. Consequently, overall operating margins can be affected by commodity-related raw material cost pressures. Commodity market prices are cyclical, reflecting overall economic trends, specific developments in consuming industries and speculative investor activities.

## **Patents and trademarks**

We hold a number of patents relating to our component products, certain of which we believe to be important to us and our continuing business activity. Patents generally have a term of 20 years, and our patents have remaining terms ranging from less than 1 year to 15 years at December 31, 2019. Our major trademarks and brand names in addition to *CompX*<sup>®</sup> include:

<b>Security Products</b>	<b>Security Products</b>	<b>Marine Components</b>
<i>CompX</i> <sup>®</sup> <i>Security Products</i> <sup>™</sup>	<i>Lockview</i> <sup>®</sup>	<i>CompX Marine</i> <sup>®</sup>
<i>National Cabinet Lock</i> <sup>®</sup>	<i>System 64</i> <sup>®</sup>	<i>Custom Marine</i> <sup>®</sup>
<i>Fort Lock</i> <sup>®</sup>	<i>SlamCAM</i> <sup>®</sup>	<i>Livorsi</i> <sup>®</sup> <i>Marine</i>
<i>Timberline</i> <sup>®</sup> <i>Lock</i>	<i>RegulatoR</i> <sup>®</sup>	<i>Livorsi II</i> <sup>®</sup> <i>Marine</i>
<i>Chicago Lock</i> <sup>®</sup>	<i>CompXpress</i> <sup>®</sup>	<i>CMI Industrial</i> <sup>®</sup>
<i>STOCK LOCKS</i> <sup>®</sup>	<i>GEM</i> <sup>®</sup>	<i>Custom Marine</i> <sup>®</sup> <i>Stainless Exhaust</i>
<i>KeSet</i> <sup>®</sup>		<i>The #1 Choice in Performance</i>
<i>TuBar</i> <sup>®</sup>		<i>Boating</i> <sup>®</sup>
<i>StealthLock</i> <sup>®</sup>		<i>Mega Rim</i> <sup>®</sup>
<i>ACE</i> <sup>®</sup>		<i>Race Rim</i> <sup>®</sup>
<i>ACE</i> <sup>®</sup> <i>II</i>		<i>Vantage View</i> <sup>®</sup>
<i>CompX eLock</i> <sup>®</sup>		<i>GEN-X</i> <sup>®</sup>

## **Sales, marketing and distribution**

A majority of our Component Products Segment's sales are direct to large OEM customers through our factory-based sales and marketing professionals supported by engineers working in concert with field salespeople and independent manufacturer's representatives. We select manufacturer's representatives based on special skills in certain markets or relationships with current or potential customers.

In addition to sales to large OEM customers, a substantial portion of our security products sales are made through distributors. We have a significant North American market share of cabinet lock security products sales as a result of the locksmith distribution channel. We support our locksmith distributor sales with a line of standardized products used by the largest segments of the marketplace. These products are packaged and merchandised for easy availability and handling by distributors and end users.

Our Component Products Segment sells to a diverse customer base with only one customer representing 10% or more of our Component Products Segment's sales in 2019 (United States Postal Service representing 14%). Our Component Products Segment's largest ten customers accounted for approximately 47% of its sales in 2019.

## **Competition**

The markets in which our Component Products Segment participates are highly competitive. We compete primarily on the basis of product design, including space utilization and aesthetic factors, product quality and durability, price, on-time delivery, service and technical support. We focus our efforts on the middle and high-end segments of the market, where product design, quality, durability and service are valued by the customer. Our security products reporting unit competes against a number of domestic and foreign manufacturers. Our marine components reporting unit competes with small domestic manufacturers and is minimally affected by foreign competitors.

## **Regulatory and environmental matters**

Our Component Products Segment's operations are subject to federal, state and local laws and regulations relating to the use, storage, handling, generation, transportation, treatment, emission, discharge, disposal, remediation of and exposure to hazardous and non-hazardous substances, materials and wastes ("Environmental Laws"). Our operations also are subject to federal, state and local laws and regulations relating to worker health and safety. We believe we are in substantial compliance with all such laws and regulations. To date, the costs of maintaining compliance with such laws and regulations have not significantly impacted our results. We currently do not anticipate any significant costs or expenses relating to such matters; however, it is possible future laws and regulations may require us to incur significant additional expenditures.

## **Employees**

As of December 31, 2019, our Component Products Segment employed 547 people, all in the United States. We believe our labor relations are good at all of our facilities.

## **REAL ESTATE MANAGEMENT AND DEVELOPMENT SEGMENT—BASIC MANAGEMENT, INC. AND THE LANDWELL COMPANY**

### ***Business overview***

Our Real Estate Management and Development Segment consists of BMI and LandWell. BMI provides utility services, among other things, to an industrial park located in Henderson, Nevada and is responsible for the delivery of water to the City of Henderson and various other users through a water distribution system owned by BMI. LandWell is actively engaged in efforts to develop certain real estate in Henderson, Nevada including approximately 2,100 acres zoned for residential/planned community purposes and approximately 400 acres zoned for commercial and light industrial use.

### ***Operations and services***

Over the years, LandWell and BMI have focused on developing and selling the land transferred to LandWell as part of its formation in the early 1950's as well as additional land holdings acquired by LandWell in the surrounding area subsequent to LandWell's formation (although BMI and LandWell have not had significant real property acquisitions since 2004). Since LandWell's formation, LandWell and BMI have a history of successfully developing and selling over 1,200 acres of retail light industrial, commercial and residential projects in the Henderson, Nevada area. However, a substantial portion of such projects had been completed prior to the 2008 economic downturn which was particularly acute in the Las Vegas area real estate market that includes Henderson. Following such economic downturn, LandWell's land sales were substantially reduced as compared to prior years, and LandWell did not recognize any material amount of land sales in the 2008 to 2013 time period. During this time period, LandWell focused primarily on the remediation and development of a large tract of land in Henderson zoned for residential/planned community purposes (approximately 2,100 acres). Planning and zoning work on such project began in 2007, but LandWell delayed significant development efforts until economic conditions had improved. As general economic conditions improved in 2011 and 2012, LandWell began intensive development efforts of the residential/planned community in 2013 (with LandWell acting as the master developer for all such development efforts). We market and sell our residential/planned community to established home builders in tracts of land that are pre-zoned for a maximum number of home lots. We support the builders' efforts to market and sell specific residential homes within our residential/planned community through joint marketing campaign and community wide education efforts.

In addition, BMI delivers utility services to an industrial park located in Henderson, Nevada and also delivers water to the City of Henderson and various other users through a water delivery system owned by BMI.

### ***Sales***

Through December 31, 2019, LandWell has closed or entered into escrow on approximately 645 acres of the residential/planned community and approximately 65 acres zoned for commercial and light industrial use. Contracts for land sales are negotiated on an individual basis and sales terms and prices will vary based on such factors as location (including location within a planned community), expected development work and individual buyer needs. Although land may be under contract, we do not recognize revenue until we have satisfied the criteria for revenue recognition. In some instances, we will receive cash proceeds at the time the contract closes and record deferred revenue for some or all of the cash amount received, with such deferred revenue being recognized in subsequent periods. Because land held for development was initially recognized at estimated fair value at the acquisition date, we do not expect to recognize significant operating income on land sales for the land currently under contract. We expect the development work to continue for 7 to 10 years on the rest of the land held for development, especially the remainder of the residential/planned community.

Our Real Estate Management and Development Segment's sales consist principally of land sales and water and electric delivery fees. During 2019 we had sales to four customers that each exceeded 10% of our Real Estate Management and Development Segment's net sales: Richmond Homes of Nevada (38%), Grey Stone Nevada, LLC (22%) and Woodside Homes of Nevada, LLC (10%), all related to land sales, and the City of Henderson (10%) related to water delivery sales.

### ***Competition***

There are multiple new construction residential communities in the greater Las Vegas, Nevada area. We compete with these communities on the basis of location; planned community amenities and features; proximity to major retail and recreational activities; and the perception of quality of life within the new community. We believe our residential/planned community is unique within the greater Las Vegas area due to its location and planned amenities which include 490 acres of community and neighborhood parks and open space interconnected with major regional trails and parks. We are marketing our residential/planned community to builders who target first-time to middle market home buyers to maximize sales.

## ***Regulatory and environmental matters***

We and the subcontractors we use must comply with many federal, state and local laws and regulations, including zoning, density and development requirements, building, environmental, advertising, labor and real estate sales rules and regulations. These regulations and requirements affect substantially all aspects of our land development. Our operations are subject to federal, state and local laws and regulations relating to the use, storage, handling, generation, transportation, treatment, emission, discharge, disposal, remediation of and exposure to hazardous and non-hazardous substances, materials and wastes. Our operations also are subject to federal, state and local laws and regulations relating to worker health and safety. We believe we are in substantial compliance with all such laws and regulations. To date, the costs of maintaining compliance with such laws and regulations have not significantly impacted our results. We currently do not anticipate any significant costs or expenses relating to such matters; however, it is possible future laws and regulations may require us to incur significant additional expenditures.

## ***Employees***

At December 31, 2019, our Real Estate Management and Development Segment had 28 employees. We believe our labor relations are good.

## **OTHER**

***NL Industries, Inc.***—At December 31, 2019, NL owned 86% of CompX and 30% of Kronos. NL also owns 100% of EWI RE, Inc., an insurance brokerage and risk management services company. In the fourth quarter of 2019, NL sold the insurance and risk management business of EWI for proceeds of \$3.25 million and recognized a gain of \$3.0 million. NL also holds certain marketable securities and other investments. See Note 17 to our Consolidated Financial Statements for additional information.

***Tremont LLC***—Tremont is primarily a holding company through which we hold our 63% ownership interest in BMI and our 77% ownership interest in LandWell. Such 77% ownership interest in LandWell includes 27% we hold through our ownership of Tremont and 50% held by a subsidiary of BMI. Tremont also owns 100% of Tall Pines Insurance Company, an insurance company that also holds certain marketable securities and other investments. Tremont also owns certain real property in Henderson, Nevada. See Note 17 to our Consolidated Financial Statements.

In addition, we also own real property related to certain of our former business units.

***Discontinued Operations***—On January 26, 2018, we completed the sale of the Waste Management Segment to JFL-WCS Partners, LLC, an entity sponsored by certain investment affiliates of J.F. Lehman & Company, for consideration consisting of the assumption of all of the Waste Management Segment's third-party indebtedness and other liabilities. We recognized a pre-tax gain of approximately \$58 million on the transaction in the first quarter of 2018 because the carrying value of the liabilities of the business assumed by the purchaser exceeded the carrying value of the assets sold at the time of sale in large part due to the long-lived asset impairment of \$170.6 million recognized with respect to the Waste Management Segment in the second quarter of 2017. Such pre-tax gain is classified as part of discontinued operations. See Note 3 to our Consolidated Financial Statements for additional information.

***Business Strategy***—We routinely compare our liquidity requirements and alternative uses of capital against the estimated future cash flows to be received from our subsidiaries and unconsolidated affiliates, and the estimated sales value of those businesses. As a result, we have in the past, and may in the future, seek to raise additional capital, refinance or restructure indebtedness, repurchase indebtedness in the market or otherwise, modify our dividend policy, consider the sale of an interest in our subsidiaries, business units, marketable securities or other assets, or take a combination of these or other steps, to increase liquidity, reduce indebtedness and fund future activities, which have in the past and may in the future involve related companies. From time to time, we and our related entities consider restructuring ownership interests among our subsidiaries and related companies. We expect to continue this activity in the future.

We and other entities that may be deemed to be controlled by or affiliated with Ms. Simmons, Ms. Connelly and the Family Trust routinely evaluate acquisitions of interests in, or combinations with, companies, including related companies, we perceive to be undervalued in the marketplace. These companies may or may not be engaged in businesses related to our current businesses. In some instances we actively manage the businesses we acquire with a focus on maximizing return-on-investment through cost reductions, capital expenditures, improved operating efficiencies, selective marketing to address market niches, disposition of marginal operations, use of leverage and redeployment of capital to more productive assets. In other instances, we have disposed of our interest in a company prior to gaining control. We intend to consider such activities in the future and may, in connection with such activities, consider issuing additional equity securities and increasing our indebtedness.

***Website and Available Information***—Our fiscal year ends December 31. We furnish our stockholders with annual reports containing audited financial statements. In addition, we file annual, quarterly and current reports, proxy and information statements and other information with the SEC. Certain of our consolidated subsidiaries (Kronos, NL and CompX) also file annual, quarterly and current reports, proxy and information statements and other information with the SEC. We also make our annual reports on Form 10-

K, quarterly reports on Form 10-Q, current reports on Form 8-K and amendments thereto, available free of charge through our website at [www.valhi.net](http://www.valhi.net) as soon as reasonably practical after they have been filed with the SEC. We also provide to anyone, without charge, copies of such documents upon written request. Requests should be directed to the attention of the Corporate Secretary at our address on the cover page of this Form 10-K.

Additional information, including our Audit Committee charter, our Code of Business Conduct and Ethics and our Corporate Governance Guidelines, can also be found on our website. Information contained on our website is not part of this Annual Report.

The SEC maintains an Internet website at [www.sec.gov](http://www.sec.gov) that contains reports, proxy and information statements and other information regarding issuers, such as us, that file electronically with the SEC.

## ITEM 1A. RISK FACTORS

Listed below are certain risk factors associated with us and our businesses. See also certain risk factors discussed in Item 7 — “*Management’s Discussion and Analysis of Financial Condition and Results of Operations — Critical Accounting Policies and Estimates.*” In addition to the potential effect of these risk factors, any risk factor which could result in reduced earnings or increased operating losses, or reduced liquidity, could in turn adversely affect our ability to service our liabilities or pay dividends on our common stock or adversely affect the quoted market prices for our securities.

### **Our assets consist primarily of investments in our operating subsidiaries, and we are dependent upon distributions from our subsidiaries to service our liabilities.**

The majority of our operating cash flows are generated by our operating subsidiaries, and our ability to service liabilities and pay dividends on our common stock depends to a large extent upon the cash dividends or other distributions we receive from our subsidiaries. Our subsidiaries are separate and distinct legal entities and they have no obligation, contingent or otherwise, to pay cash dividends or other distributions to us. In addition, the payment of dividends or other distributions from our subsidiaries could be subject to restrictions under applicable law, monetary transfer restrictions, currency exchange regulations in jurisdictions in which our subsidiaries operate or any other restrictions imposed by current or future agreements to which our subsidiaries may be a party, including debt instruments. Events beyond our control, including changes in general business and economic conditions, could adversely impact the ability of our subsidiaries to pay dividends or make other distributions to us. If our subsidiaries were to become unable to make sufficient cash dividends or other distributions to us, our ability to service our liabilities and to pay dividends on our common stock could be adversely affected.

In addition, a significant portion of our assets consist of ownership interests in our subsidiaries. If we were required to liquidate our subsidiaries’ securities in order to generate funds to satisfy our liabilities, we may be required to sell such securities at a time or times for less than what we believe to be the long-term value of such assets.

### **Demand for, and prices of, certain of our Chemicals Segment’s products are influenced by changing market conditions for its products, which may result in reduced earnings or operating losses.**

Our Chemicals Segment’s sales and profitability are largely dependent on the TiO<sub>2</sub> industry. In 2019, 94% of our Chemicals Segment’s sales were attributable to sales of TiO<sub>2</sub>. TiO<sub>2</sub> is used in many “quality of life” products for which demand historically has been linked to global, regional and local gross domestic product and discretionary spending, which can be negatively impacted by regional and world events or economic conditions. Such events are likely to cause a decrease in demand for our products and, as a result, may have an adverse effect on our results of operations and financial condition.

Pricing within the global TiO<sub>2</sub> industry over the long term is cyclical and changes in economic conditions worldwide can significantly impact our earnings and operating cash flows. Historically, the markets for many of our products have experienced alternating periods of increasing and decreasing demand. Relative changes in the selling prices for our products are one of the main factors that affect the level of our profitability. In periods of increasing demand, our selling prices and profit margins generally will tend to increase, while in periods of decreasing demand our selling prices and profit margins generally tend to decrease. In addition, pricing may affect customer inventory levels as customers may from time to time accelerate purchases of TiO<sub>2</sub> in advance of anticipated price increases or defer purchases of TiO<sub>2</sub> in advance of anticipated price decreases. Our ability to further increase capacity without additional investment in greenfield or brownfield capacity increases may be limited and as a result, our profitability may become even more dependent upon the selling prices of our products.

### **The TiO<sub>2</sub> industry is concentrated and highly competitive and we face price pressures in the markets in which we operate, which may result in reduced earnings or operating losses.**

The global market in which we operate our Chemicals Segment is concentrated, with the top five TiO<sub>2</sub> producers accounting for approximately 52% of the world’s production capacity, and is highly competitive. Competition is based on a number of factors, such as price, product quality and service. Some of our competitors may be able to drive down prices for our products if their costs are lower than our costs. In addition, some of our competitors’ financial, technological and other resources may be greater than our resources and such competitors may be better able to withstand changes in market conditions. Our competitors may be able to respond more quickly than we can to new or emerging technologies and changes in customer requirements. Further, consolidation of our competitors or customers may result in reduced demand for our products or make it more difficult for us to compete with our competitors. The occurrence of any of these events could result in reduced earnings or operating losses.

### **Higher costs or limited availability of our raw materials may reduce our earnings and decrease our liquidity. In addition, many of our raw material contracts contain fixed quantities we are required to purchase.**

For our Chemicals Segment, the number of sources for and availability of certain raw materials is specific to the particular geographical region in which a facility is located. For example, titanium-containing feedstocks suitable for use in our Chemicals Segment’s TiO<sub>2</sub> facilities are available from a limited number of suppliers around the world. Political and economic instability in the countries from which we purchase our raw material supplies could adversely affect their availability. If our Chemicals Segment’s

worldwide vendors were unable to meet their contractual obligations and we were unable to obtain necessary raw materials, we could incur higher costs for raw materials or may be required to reduce production levels. Our Chemicals Segment experienced increases in feedstock costs in 2018 and 2019, and we expect our feedstock costs to continue to increase in the first half of 2020 before moderating slightly in the second half of 2020. Our Chemicals Segment may also experience higher operating costs such as energy costs, which could affect our profitability. We may not always be able to increase its selling prices to offset the impact of any higher costs or reduced production levels, which could reduce our earnings and decrease our liquidity.

Our Chemicals Segment has long-term supply contracts that provide for our TiO<sub>2</sub> feedstock requirements that currently expire through 2022. While we believe we will be able to renew these contracts, there can be no assurance we will be successful in renewing them or in obtaining long-term extensions to them prior to expiration. Our current agreements (including those entered into through February 2020) require us to purchase certain minimum quantities of feedstock with minimum purchase commitments aggregating approximately \$897 million beginning in 2020. In addition, we have other long-term supply and service contracts that provide for various raw materials and services. These agreements require us to purchase certain minimum quantities or services with minimum purchase commitments aggregating approximately \$74 million at December 31, 2019. Our commitments under these contracts could adversely affect our financial results if we significantly reduce our production and were unable to modify the contractual commitments.

Certain raw materials used in our Component Products Segment's products are commodities that are subject to significant fluctuations in price in response to world-wide supply and demand as well as speculative investor activity. Zinc and brass are the principal raw materials used in the manufacture of security products. Stainless steel and aluminum are the major raw materials used in the manufacture of marine components. These raw materials are purchased from several suppliers and are generally readily available from numerous sources. Our Component Products Segment occasionally enters into short-term raw material supply arrangements to mitigate the impact of future increases in commodity-related raw material costs. Materials purchased outside of these arrangements are sometimes subject to unanticipated and sudden price increases.

Certain components used in our Component Products Segment's products are manufactured by foreign suppliers located in China and elsewhere. Global economic and political conditions, including natural disasters, terrorist acts, global conflict and public health crises such as the coronavirus, could prevent our Component Products Segment's vendors from being able to supply these components. Should our Component Products Segment's vendors not be able to meet their contractual obligations or should it be otherwise unable to obtain necessary raw materials or components, it may incur higher supply costs or may be required to reduce production levels, either of which may decrease our liquidity or negatively impact our financial condition or results of operations as our Component Products Segment may be unable to offset the higher costs with increases in its selling prices or reductions in other operating costs.

**We could incur significant costs related to legal and environmental remediation matters.**

NL formerly manufactured lead pigments for use in paint. NL and others have been named as defendants in various legal proceedings seeking damages for personal injury, property damage and governmental expenditures allegedly caused by the use of lead-based paints. These lawsuits seek recovery under a variety of theories, including public and private nuisance, negligent product design, negligent failure to warn, strict liability, breach of warranty, conspiracy/concert of action, aiding and abetting, enterprise liability, market share or risk contribution liability, intentional tort, fraud and misrepresentation, violations of state consumer protection statutes, supplier negligence and similar claims. The plaintiffs in these actions generally seek to impose on the defendants responsibility for lead paint abatement and health concerns associated with the use of lead-based paints, including damages for personal injury, contribution and/or indemnification for medical expenses, medical monitoring expenses and costs for educational programs. NL entered into a legal settlement in one public-nuisance lead pigment case and has recognized a material liability related to the settlement. Any additional liability we might incur in the future for these matters could be material. See also Item 3 - "Legal Proceedings - Lead pigment litigation - NL."

Certain properties and facilities used in our former operations are the subject of litigation, administrative proceedings or investigations arising under various environmental laws. These proceedings seek cleanup costs, personal injury or property damages and/or damages for injury to natural resources. Some of these proceedings involve claims for substantial amounts. Environmental obligations are difficult to assess and estimate for numerous reasons, and we may incur costs for environmental remediation in the future in excess of amounts currently estimated. Any liability we might incur in the future could be material. See also Item 3 - "Legal Proceedings - Environmental matters and litigation."

**Many of the markets in which our Component Products Segment operates are mature and highly competitive resulting in pricing pressure and the need to continuously reduce costs.**

Many of the markets our Component Products Segment serves are highly competitive, with a number of competitors offering similar products. We focus our efforts on the middle and high-end segment of the market where we feel that we can compete due to the importance of product design, quality and durability to the customer. However, our ability to effectively compete is impacted by a number of factors. The occurrence of any of these factors could result in reduced earnings or operating losses.

- Competitors may be able to drive down prices for our products beyond our ability to adjust costs because their costs are lower than ours, especially products sourced from Asia.
- Competitors' financial, technological and other resources may be greater than our resources, which may enable them to more effectively withstand changes in market conditions.
- Competitors may be able to respond more quickly than we can to new or emerging technologies and changes in customer requirements.
- A reduction of our market share with one or more of our key customers, or a reduction in one or more of our key customers' market share for their end-use products, may reduce demand for our products.
- New competitors could emerge by modifying their existing production facilities to manufacture products that compete with our products.
- We may not be able to sustain a cost structure that enables us to be competitive.
- Customers may no longer value our product design, quality or durability over the lower cost products of our competitors.

**Our development of innovative features for current products is critical to sustaining and growing our Component Product Segment's sales.**

Historically, our Component Products Segment's ability to provide value-added custom engineered products that address requirements of technology and space utilization has been a key element of our success. We spend a significant amount of time and effort to refine, improve and adapt our existing products for new customers and applications. Since expenditures for these types of activities are not considered research and development expense under accounting principles generally accepted in the United States of America ("GAAP"), the amount of our research and development expenditures, which is not significant, is not indicative of the overall effort involved in the development of new product features. The introduction of new product features requires the coordination of the design, manufacturing and marketing of the new product features with current and potential customers. The ability to coordinate these activities with current and potential customers may be affected by factors beyond our control. While we will continue to emphasize the introduction of innovative new product features that target customer-specific opportunities, we do not know if any new product features we introduce will achieve the same degree of success that we have achieved with our existing products. Introduction of new product features typically requires us to increase production volumes on a timely basis while maintaining product quality. Manufacturers often encounter difficulties in increasing production volumes, including delays, quality control problems and shortages of qualified personnel or raw materials. As we attempt to introduce new product features in the future, we do not know if we will be able to increase production volumes without encountering these or other problems, which might negatively impact our financial condition or results of operations.

**If our intellectual property were to be declared invalid, or copied by or become known to competitors, or if our competitors were to develop similar or superior intellectual property or technology, our ability to compete could be adversely impacted.**

Protection of our intellectual property rights, including patents, trade secrets, confidential information, trademarks and tradenames, is important to our businesses and our competitive positions. We endeavor to protect our intellectual property rights in key jurisdictions in which our products are produced or used and in jurisdictions into which our products are imported. However, we may be unable to obtain protection for our intellectual property in key jurisdictions. Although we own and have applied for numerous patents and trademarks throughout the world, we may have to rely on judicial enforcement of our patents and other proprietary rights. Our patents and other intellectual property rights may be challenged, invalidated, circumvented, and rendered unenforceable or otherwise compromised. A failure to protect, defend or enforce our intellectual property could have an adverse effect on our financial condition and results of operations. Similarly, third parties may assert claims against us and our customers and distributors alleging our products infringe upon third-party intellectual property rights.

It is the practice of our Chemicals Segment to enter into confidentiality agreements with its employees and third parties to protect our proprietary expertise and other trade secrets; however these agreements may not provide sufficient protection for our trade secrets or proprietary know-how, or adequate remedies for breaches of such agreements may not be available in the event of an unauthorized use or disclosure of such trade secrets and know-how. We also may not be able to readily detect breaches of such agreements. The failure of our patents or confidentiality agreements to protect our proprietary technology, know-how or trade secrets could result in a material loss of our competitive position, which could lead to significantly lower revenues, reduced profit margins or loss of market share.



Our Component Products Segment relies on patent, trademark and trade secret laws in the United States and similar laws in other countries to establish and maintain our intellectual property rights in our technology and designs. Despite these measures, any of our intellectual property rights could be challenged, invalidated, circumvented or misappropriated. Others may independently discover our trade secrets and proprietary information, and in such cases we could not assert any trade secret rights against such parties. Further, we do not know if any of our pending trademark or patent applications will be approved. Costly and time-consuming litigation could be necessary to enforce and determine the scope of our intellectual property rights. In addition, the laws of certain countries do not protect intellectual property rights to the same extent as the laws of the United States. Therefore, in certain jurisdictions, we may be unable to protect our technology and designs adequately against unauthorized third party use, which could adversely affect our competitive position.

Third parties may claim that we or our customers are infringing upon their intellectual property rights. Even if we believe that such claims are without merit, they can be time-consuming and costly to defend and distract our management's and technical staff's attention and resources. Claims of intellectual property infringement also might require us to redesign affected technology, enter into costly settlement or license agreements or pay costly damage awards, or face a temporary or permanent injunction prohibiting us from marketing or selling certain of our technology. If we cannot or do not license the infringed technology on reasonable pricing terms or at all, or substitute similar technology from another source, our business could be adversely impacted.

If we must take legal action to protect, defend or enforce our intellectual property rights, any suits or proceedings could result in significant costs and diversion of resources and management's attention, and we may not prevail in any such suits or proceedings. A failure to protect, defend or enforce our intellectual property rights could have an adverse effect on our financial condition and results of operations.

**Our Real Estate Management and Development Segment owns a significant amount of real property in Henderson, Nevada. A prolonged downturn in the local real estate market in Nevada could negatively impact our ability to successfully complete the development of such real property.**

A substantial portion of the revenues and assets associated with our Real Estate Management and Development Segment relates to certain real estate under development in Henderson, Nevada, including approximately 2,100 acres zoned for residential/planned community purposes and approximately 400 acres zoned for commercial and light industrial use. A prolonged downturn in the local real estate market in Nevada or other events could negatively impact our ability to successfully complete the development of such real property, either by requiring us to incur future development costs in excess of our current estimates, or by resulting in selling prices for future land sales lower than what we currently expect. If any of these events were to occur, revenue and profits in our Real Estate Management and Development segment may be significantly and negatively affected.

**Our leverage may impair our financial condition or limit our ability to operate our businesses.**

We have a significant amount of debt, primarily related to Kronos' Senior Notes, our loan from Contran Corporation, and the BMI and LandWell bank notes. As of December 31, 2019, our total consolidated debt was approximately \$794 million. Our level of debt could have important consequences to our stockholders and creditors, including:

- making it more difficult for us to satisfy our obligations with respect to our liabilities;
- increasing our vulnerability to adverse general economic and industry conditions;
- requiring that a portion of our cash flows from operations be used for the payment of interest on our debt, which reduces our ability to use our cash flow to fund working capital, capital expenditures, dividends on our common stock, acquisitions or general corporate requirements;
- limiting the ability of our subsidiaries to pay dividends to us;
- limiting our ability to obtain additional financing to fund future working capital, capital expenditures, acquisitions or general corporate requirements;
- limiting our flexibility in planning for, or reacting to, changes in our businesses and the industries in which we operate; and
- placing us at a competitive disadvantage relative to other less leveraged competitors.

In addition to our indebtedness, we are party to various lease and other agreements (including feedstock ore purchase contracts as previously described) pursuant to which, along with our indebtedness, we are committed to pay approximately \$642 million in 2020. Our ability to make payments on and refinance our debt and to fund planned capital expenditures depends on our future ability to generate cash flow. To some extent, this is subject to general economic, financial, competitive, legislative, regulatory and other factors that are beyond our control. In addition, our ability to borrow funds under certain of our revolving credit

facilities in the future will, in some instances, depend in part on these subsidiaries' ability to maintain specified financial ratios and satisfy certain financial covenants contained in the applicable credit agreement.

Our businesses may not generate cash flows from operating activities sufficient to enable us to pay our debts when they become due and to fund our other liquidity needs. As a result, we may need to refinance all or a portion of our debt before maturity. We may not be able to refinance any of our debt in a timely manner on favorable terms, if at all, in the current credit markets. Any inability to generate sufficient cash flows or to refinance our debt on favorable terms could have a material adverse effect on our financial condition.

**Operating as a global business presents risks associated with global and regional economic, political and regulatory environments.**

We have significant international operations which, along with our customers and suppliers, could be substantially affected by a number of risks arising from operating a multi-national business, including trade barriers, tariffs, exchange controls, global and regional economic downturns, terrorism, health crises (such as the coronavirus) and political conditions. We may encounter difficulties enforcing agreements or other legal rights and our effective tax rate may fluctuate based on the variability of geographic earnings and statutory tax rates, including costs associated with the repatriation of non-U.S. earnings. These risks, individually or in the aggregate, could have an adverse effect on our results of operations and financial condition.

**Changes in exchange rates and interest rates can adversely affect our net sales, profits and cash flows.**

We operate our businesses in several different countries and sell our products worldwide. For example, during 2019, 46% of our Chemicals Segment's sales volumes were sold into European markets. The majority (but not all) of our sales from our Chemicals Segment's operations outside the United States are denominated in currencies other than the United States dollar, primarily the euro, other major European currencies and the Canadian dollar. Therefore, we are exposed to risks related to the need to convert currencies we receive from the sale of our products into the currencies required to pay for certain of our operating costs and expenses and other liabilities (including indebtedness), all of which could result in future losses depending on fluctuations in currency exchange rates and affect the comparability of our results of operations between periods.

**Environmental, health and safety laws and regulations may result in increased regulatory scrutiny which could decrease demand for our products, increase our manufacturing and compliance costs or obligations and result in unanticipated losses which could negatively impact our financial results or limit our ability to operate our Chemicals Segment's business.**

From time to time, new environmental, health and safety regulations are passed or proposed in the countries in which we operate or sell our products, seeking to regulate our operations or to restrict, limit or classify TiO<sub>2</sub>, or its use (such as the classification of TiO<sub>2</sub> powder as a suspected carcinogen in the EU). Increased regulatory scrutiny could affect consumer perception of TiO<sub>2</sub> or limit the marketability and demand for TiO<sub>2</sub> or products containing TiO<sub>2</sub>, and increase our manufacturing and regulatory compliance obligations and costs. Increased compliance obligations and costs or restrictions on certain TiO<sub>2</sub> applications could negatively impact our future financial results through increased costs of production, or reduced sales which may decrease our liquidity, operating income and results of operations.

**Global climate change legislation could negatively impact our financial results or limit our ability to operate our businesses.**

We operate production facilities in several countries. In many of the countries in which we operate, legislation has been passed, or proposed legislation is being considered, to limit greenhouse gases through various means, including emissions permits and/or energy taxes. In several of our production facilities, we consume large amounts of energy, primarily electricity and natural gas. To date, the permit system in effect in the various countries in which we operate has not had a material adverse effect on our financial results. However, if further greenhouse gas legislation were to be enacted in one or more countries, it could negatively impact our future results of operations through increased costs of production, particularly as it relates to our energy requirements or our need to obtain emissions permits. If such increased costs of production were to materialize, we may be unable to pass price increases on to our customers to compensate for increased production costs, which may decrease our liquidity, operating income and results of operations.

**Technology failures or cyber security breaches could have a material adverse effect on our operations.**

We rely on integrated information technology systems to manage, process and analyze data, including to facilitate the manufacture and distribution of our products to and from our plants, receive, process and ship orders, manage the billing of and collections from our customers and manage payments to our vendors. Although we have systems and procedures in place to protect our information technology systems, there can be no assurance that such systems and procedures would be sufficiently effective. Therefore, any of our information technology systems may be susceptible to outages, disruptions or destruction as well as

cyber security breaches or attacks, resulting in a disruption of our business operations, injury to people, harm to the environment or our assets, and/or the inability to access our information technology systems. If any of these events were to occur, our results of operations and financial condition could be adversely affected.

#### **ITEM 1B. UNRESOLVED STAFF COMMENTS**

None.

#### **ITEM 2. PROPERTIES**

We along with our subsidiaries, Kronos, CompX and NL lease office space through Contran for our principal executive offices in Dallas, Texas. Our BMI and LandWell subsidiaries' principal offices are in an owned building in Henderson, Nevada. A list of principal operating facilities for each of our subsidiaries is described in the applicable business sections of Item 1—"Business." We believe our facilities are generally adequate and suitable for their respective uses.

#### **ITEM 3. LEGAL PROCEEDINGS**

We are involved in various legal proceedings. In addition to information included below, certain information called for by this Item is included in Note 18 to our Consolidated Financial Statements, which is incorporated herein by reference.

##### ***Lead Pigment Litigation—NL***

Our former operations included the manufacture of lead pigments for use in paint and lead-based paint. We, other former manufacturers of lead pigments for use in paint and lead-based paint (together, the "former pigment manufacturers"), and the Lead Industries Association (LIA), which discontinued business operations in 2002, have been named as defendants in various legal proceedings seeking damages for personal injury, property damage and governmental expenditures allegedly caused by the use of lead-based paints. Certain of these actions have been filed by or on behalf of states, counties, cities or their public housing authorities and school districts, and certain others have been asserted as class actions. These lawsuits seek recovery under a variety of theories, including public and private nuisance, negligent product design, negligent failure to warn, strict liability, breach of warranty, conspiracy/concert of action, aiding and abetting, enterprise liability, market share or risk contribution liability, intentional tort, fraud and misrepresentation, violations of state consumer protection statutes, supplier negligence and similar claims.

The plaintiffs in these actions generally seek to impose on the defendants responsibility for lead paint abatement and health concerns associated with the use of lead-based paints, including damages for personal injury, contribution and/or indemnification for medical expenses, medical monitoring expenses and costs for educational programs. To the extent the plaintiffs seek compensatory or punitive damages in these actions, such damages are generally unspecified. In some cases, the damages are unspecified pursuant to the requirements of applicable state law. A number of cases are inactive or have been dismissed or withdrawn. Most of the remaining cases are in various pre-trial stages. Some are on appeal following dismissal or summary judgment rulings or a trial verdict in favor of either the defendants or the plaintiffs.

We believe that these actions are without merit, and we intend to continue to deny all allegations of wrongdoing and liability and to defend against all actions vigorously. Other than with respect to the Santa Clara California public nuisance case discussed below, we do not believe it is probable that we have incurred any liability with respect to all of the lead pigment litigation cases to which we are a party, and with respect to all such lead pigment litigation cases to which we are a party, other than with respect to the Santa Clara case discussed below, we believe liability to us that may result, if any, in this regard cannot be reasonably estimated, because:

- we have never settled any of the market share, intentional tort, fraud, nuisance, supplier negligence, breach of warranty, conspiracy, misrepresentation, aiding and abetting, enterprise liability, or statutory cases (other than the Santa Clara case discussed below),
- no final, non-appealable adverse verdicts have ever been entered against NL, and
- we have never ultimately been found liable with respect to any such litigation matters, including over 100 cases over a thirty-year period for which we were previously a party and for which we have been dismissed without any finding of liability.

Accordingly, other than with respect to the Santa Clara case discussed below, we have not accrued any amounts for any of the pending lead pigment and lead-based paint litigation cases filed by or on behalf of states, counties, cities or their public housing authorities and school districts, or those asserted as class actions other than the Santa Clara case noted below. In addition, we have determined that

liability to us which may result, if any, cannot be reasonably estimated at this time because there is no prior history of a loss of this nature on which an estimate could be made and there is no substantive information available upon which an estimate could be based.

In the matter titled *County of Santa Clara v. Atlantic Richfield Company, et al.* (Superior Court of the State of California, County of Santa Clara, Case No. 1-00-CV-788657) on July 24, 2019, an order approving a global settlement agreement entered into among all of the plaintiffs and the three defendants remaining in the case (the Sherwin Williams Company, ConAgra Grocery Products and NL) was entered by the court and the case was dismissed with prejudice. The global settlement agreement provides that an aggregate \$305 million will be paid collectively by the three co-defendants in full satisfaction of all claims resulting in a dismissal of the case with prejudice and the resolution of (i) all pending and future claims by the plaintiffs in the case, and (ii) all potential claims for contribution or indemnity between NL and its co-defendants in respect to the case. In the agreement, NL expressly denies any and all liability and the dismissal of the case with prejudice was entered by the court without a final judgment of liability entered against NL. The settlement agreement fully concludes this matter.

Under the terms of the global settlement agreement, each defendant must pay an aggregate \$101.7 million to the plaintiffs as follows: \$25.0 million within sixty days of the court's approval of the settlement and dismissal of the case, and the remaining \$76.7 million in six annual installments beginning on the first anniversary of the initial payment (\$12.0 million for the first five installments and \$16.7 million for the sixth installment). NL's sixth installment will be made with funds already on deposit at the court that are committed to the settlement, including all accrued interest at the date of payment, with any remaining balance to be paid by NL (and any amounts on deposit in excess of the final payment would be returned to NL).

As previously disclosed during the second quarter of 2018 and based on the terms of a May 2018 settlement agreement between NL and the plaintiffs which had an aggregate cost of \$80 million to NL, we determined that the loss to NL could be reasonably estimated and recognized a net \$62 million pre-tax charge with respect to this matter (\$45 million for the amount to be paid by NL upon approval of the terms of the settlement and \$17 million for the net present value of the five payments aggregating \$20 million to be paid by NL in installments beginning four years from such approval). The May 2018 settlement was never approved by the court and was superseded in July 2019 by the global settlement agreement discussed above.

At June 30, 2019, based on the terms of the global settlement agreement approved by the court in July 2019 we increased the amount accrued for the litigation settlement and a final immaterial adjustment was made to the litigation settlement accrual in the third quarter of 2019. For financial reporting purposes, using a discount rate of 1.9% per annum, we discounted the aggregate \$101.7 million settlement to the estimated net present value of \$96.3 million. We recognized litigation settlement expense of \$19.3 million (\$19.6 million expense in the second quarter of 2019 and \$.3 million credit in the third quarter of 2019). NL made the initial \$25.0 million payment in September 2019 and recognized an aggregate of \$.6 million in accretion expense in the second half of 2019.

For purposes of our Consolidated Balance Sheet at December 31, 2019, we have recognized the net present value of the \$12.0 million payment due in 2020, \$11.8 million, as a current liability and the net present value of the five remaining annual installments, \$60.1 million, as a noncurrent liability. Under the terms of the settlement, we reclassified the \$15.6 million on deposit at the court from an accrued insurance receivable to noncurrent restricted cash during the third quarter. Pursuant to the settlement agreement, also during the third quarter of 2019 NL placed an additional \$9.0 million into an escrow account which is included in noncurrent restricted cash on our Consolidated Balance Sheet.

In June 2000, a complaint was filed in Illinois state court, *Lewis, et al. v. Lead Industries Association, et al* (Circuit Court of Cook County, Illinois, County Department, Chancery Division, Case No. 00CH09800.) Plaintiffs seek to represent two classes, one consisting of minors between the ages of six months and six years who resided in housing in Illinois built before 1978, and another consisting of individuals between the ages of six and twenty years who lived in Illinois housing built before 1978 when they were between the ages of six months and six years and who had blood lead levels of 10 micrograms/deciliter or more. The complaint seeks damages jointly and severally from the former pigment manufacturers and the LIA to establish a medical screening fund for the first class to determine blood lead levels, a medical monitoring fund for the second class to detect the onset of latent diseases and a fund for a public education campaign. In April 2008, the trial court judge certified a class of children whose blood lead levels were screened venously between August 1995 and February 2008 and who had incurred expenses associated with such screening. In March 2012, the trial court judge decertified the class. In June 2012, the trial court judge granted plaintiffs the right to appeal his decertification order, and in August 2012 the appellate court granted plaintiffs permission to appeal. In March 2013, the appellate court agreed with the trial court's rationale regarding legislative requirements to screen children's blood lead levels and remanded the case for further proceedings in the trial court. In July 2013, plaintiffs moved to vacate the decertification. In October 2013, the judge denied plaintiffs' motion to vacate the decertification of the class. In March 2014, plaintiffs filed a new class certification motion. In April 2015, a class was certified consisting of parents or legal guardians of children who lived in certain "high risk" areas in Illinois between August 18, 1995 and February 19, 2008, and incurred an expense or liability for having their children's blood lead levels tested. In January 2019, the Illinois Supreme Court agreed to hear an interlocutory appeal addressing whether certain parents whose children's lead testing costs were fully paid by Medicaid fell within the certified class of persons who had incurred an expense for such testing. A favorable resolution of that issue could result in a reduction in the number of persons in the certified class.

In November 2018, NL was served with two complaints filed by county governments in Pennsylvania. Each county alleges that NL and several other defendants created a public nuisance by selling and promoting lead-containing paints and pigments in the counties. The plaintiffs seek abatement and declaratory relief. We believe these lawsuits are inconsistent with Pennsylvania law and without merit, and we intend to defend ourselves vigorously.

New cases may continue to be filed against NL. We cannot assure you that NL will not incur liability in the future in respect of any of the pending or possible litigation in view of the inherent uncertainties involved in court and jury rulings. In the future, if new information regarding such matters becomes available to us (such as a final, non-appealable adverse verdict against NL or otherwise ultimately being found liable with respect to such matters), at that time we would consider such information in evaluating any remaining cases then-pending against NL as to whether it might then have become probable NL has incurred liability with respect to these matters, and whether such liability, if any, could have become reasonably estimable. The resolution of any of these cases could result in the recognition of a loss contingency accrual that could have a material adverse impact on our net income for the interim or annual period during which such liability is recognized and a material adverse impact on our consolidated financial condition and liquidity.

### ***Environmental Matters and Litigation***

NL's operations are governed by various environmental laws and regulations. Certain of NL's businesses are and have been engaged in the handling, manufacture or use of substances or compounds that may be considered toxic or hazardous within the meaning of applicable environmental laws and regulations. As with other companies engaged in similar businesses, certain of our past and current operations and products have the potential to cause environmental or other damage. NL has implemented and continues to implement various policies and programs in an effort to minimize these risks. NL's policy is to maintain compliance with applicable environmental laws and regulations at all of our plants and to strive to improve environmental performance. From time to time, NL may be subject to environmental regulatory enforcement under U.S. and non-U.S. statutes, the resolution of which typically involves the establishment of compliance programs. It is possible that future developments, such as stricter requirements of environmental laws and enforcement policies, could adversely affect our production, handling, use, storage, transportation, sale or disposal of such substances. We believe all our facilities are in substantial compliance with applicable environmental laws.

Certain properties and facilities used in NL's former operations, including divested primary and secondary lead smelters and former mining locations, are the subject of civil litigation, administrative proceedings or investigations arising under federal and state environmental laws and common law. Additionally, in connection with past operating practices, NL is currently involved as a defendant, potentially responsible party (PRP) or both, pursuant to the Comprehensive Environmental Response, Compensation and Liability Act, as amended by the Superfund Amendments and Reauthorization Act (CERCLA), and similar state laws in various governmental and private actions associated with waste disposal sites, mining locations, and facilities that NL or its predecessors, subsidiaries or their predecessors currently or previously owned, operated or used, certain of which are on the United States Environmental Protection Agency's (EPA) Superfund National Priorities List or similar state lists. These proceedings seek cleanup costs, damages for personal injury or property damage and/or damages for injury to natural resources. Certain of these proceedings involve claims for substantial amounts. Although NL may be jointly and severally liable for these costs, in most cases they are only one of a number of PRPs who may also be jointly and severally liable, and among whom costs may be shared or allocated. In addition, we are occasionally named as a party in a number of personal injury lawsuits filed in various jurisdictions alleging claims related to environmental conditions alleged to have resulted from its operations.

Obligations associated with environmental remediation and related matters are difficult to assess and estimate for numerous reasons including the:

- complexity and differing interpretations of governmental regulations,
- number of PRPs and their ability or willingness to fund such allocation of costs,
- financial capabilities of the PRPs and the allocation of costs among them,
- solvency of other PRPs,
- multiplicity of possible solutions,
- number of years of investigatory, remedial and monitoring activity required,
- uncertainty over the extent, if any, to which our former operations might have contributed to the conditions allegedly giving rise to such personal injury, property damage, natural resource and related claims, and
- number of years between former operations and notice of claims and lack of information and documents about the former operations.

In addition, the imposition of more stringent standards or requirements under environmental laws or regulations, new developments or changes regarding site cleanup costs or the allocation of costs among PRPs, solvency of other PRPs, the results of future testing and analysis undertaken with respect to certain sites or a determination that we are potentially responsible for the release of hazardous substances at other sites, could cause our expenditures to exceed our current estimates. We cannot assure you that actual costs will not exceed accrued amounts or the upper end of the range for sites for which estimates have been made, and we cannot assure you that costs will not be incurred for sites where no estimates presently can be made. Further, additional environmental and related matters may arise in the future. If we were to incur any future liability, this could have a material adverse effect on our consolidated financial statements, results of operations and liquidity.

We record liabilities related to environmental remediation and related matters (including costs associated with damages for personal injury or property damage and/or damages for injury to natural resources) when estimated future expenditures are probable and reasonably estimable. We adjust such accruals as further information becomes available to us or as circumstances change. Unless the amounts and timing of such estimated future expenditures are fixed and reasonably determinable, we generally do not discount estimated future expenditures to their present value due to the uncertainty of the timing of the payout. We recognize recoveries of costs from other parties, if any, as assets when their receipt is deemed probable. At December 31, 2018 we had recognized \$15.0 million of receivables for recoveries related to the lead pigment litigation in California discussed above, and at December 31, 2019 we had not recognized any receivables for recoveries.

We do not know and cannot estimate the exact time frame over which we will make payments for our accrued environmental and related costs. Timing of payments depends upon a number of factors, including but not limited to the timing of the actual remediation process; which in turn depends on factors outside of its control. At each balance sheet date, we estimate the amount of the accrued environmental and related costs we expect to pay within the next twelve months, and we classify this estimate as a current liability. We classify the remaining accrued environmental costs as a noncurrent liability.

On a quarterly basis, we evaluate the potential range of our liability for environmental remediation and related costs at sites where we have been named as a PRP or defendant, including sites for which our wholly-owned environmental management subsidiary, NL Environmental Management Services, Inc., (EMS), has contractually assumed our obligations. At December 31, 2019, NL had accrued approximately \$95 million related to approximately 32 sites associated with remediation and related matters that NL believes are at the present time and/or in their current phase reasonably estimable. The upper end of the range of reasonably possible costs to NL for remediation and related matters for which NL believes it is possible to estimate costs is approximately \$115 million, including the amount currently accrued.

NL believes that it is not reasonably possible to estimate the range of costs for certain sites. At December 31, 2019, there were approximately five sites for which it is not currently able to reasonably estimate a range of costs. For these sites, generally the investigation is in the early stages, and we are unable to determine whether or not it actually had any association with the site, the nature of its responsibility, if any, for the contamination at the site and the extent of contamination at and cost to remediate the site. The timing and availability of information on these sites is dependent on events outside of its control, such as when the party alleging liability provides information to NL. At certain of these previously inactive sites, NL has received general and special notices of liability from the EPA and/or state agencies alleging that it, sometimes with other PRPs, are liable for past and future costs of remediating environmental contamination allegedly caused by former operations. These notifications may assert that NL, along with any other alleged PRPs, are liable for past and/or future clean-up costs. As further information becomes available to us for any of these sites, which would allow us to estimate a range of costs, we would at that time adjust our accruals. Any such adjustment could result in the recognition of an accrual that would have a material effect on our consolidated financial statements, results of operations and liquidity.

In June 2008, NL received a Directive and Notice to Insurers from the New Jersey Department of Environmental Protection (NJDEP) regarding the Margaret's Creek site in Old Bridge Township, New Jersey. NJDEP alleged that a waste hauler transported waste from one of its former facilities for disposal at the site in the early 1970s. NJDEP referred the site to the EPA, and in November 2009, the EPA added the site to the National Priorities List under the name "Raritan Bay Slag Site." In 2012, EPA notified NL of its potential liability at this site. In May 2013, EPA issued its Record of Decision for the site. In June 2013, NL filed a contribution suit under CERCLA and the New Jersey Spill Act titled *NL Industries, Inc. v. Old Bridge Township, et al.* (United States District Court for the District of New Jersey, Civil Action No. 3:13-cv-03493-MAS-TJB) against the current owner, Old Bridge Township, and several federal and state entities NL alleges designed and operated the site and who have significant potential liability as compared to NL which is alleged to have been a potential source of material placed at the site by others. NL's suit also names certain former NL customers of the former NL facility alleged to be the source of some of the materials. In January 2014, EPA issued a Unilateral Administrative Order (UAO) to NL for clean-up of the site based on the EPA's preferred remedy set forth in the Record of Decision. NL is in discussions with EPA about NL's performance of a defined amount of the work at the site and is otherwise taking actions necessary to respond to the UAO. If these discussions and actions are unsuccessful, NL will defend vigorously against all claims while continuing to seek contribution from other PRPs. In March 2017, in a parallel lawsuit initiated by NL in state court against the State of New Jersey, which has significant potential liability as compared to NL, the New Jersey Supreme Court ruled that the State of New Jersey had not waived its immunity under the Spill Act for its pre-1977 conduct. In August 2017, NL filed an amended complaint in the state court alleging post-1977 conduct by the State that led to contamination. In September 2017, the State filed its

answer and counterclaims. NL has denied liability on the State's counterclaims and intends to continue to seek contribution from the State.

In August 2009, NL was served with a complaint in *Raritan Baykeeper, Inc. d/b/a NY/NJ Baykeeper et al. v. NL Industries, Inc. et al.* (United States District Court, District of New Jersey, Case No. 3:09-cv-04117). This is a citizen's suit filed by two local environmental groups pursuant to the Resource Conservation and Recovery Act and the Clean Water Act against NL, current owners, developers and state and local government entities. The complaint alleges that hazardous substances were and continue to be discharged from its former Sayreville, New Jersey property into the sediments of the adjacent Raritan River. The former Sayreville site is currently being remediated by owner/developer parties under the oversight of the NJDEP. The plaintiffs seek a declaratory judgment, injunctive relief, imposition of civil penalties and an award of costs. NL has denied liability and will defend vigorously against all claims.

In June 2011, NL was served in *ASARCO LLC v. NL Industries, Inc., et al.* (United States District Court, Western District of Missouri, Case No. 4:11-cv-00138-DGK). The plaintiff brought this CERCLA contribution action against several defendants to recover a portion of the amount it paid in settlement with the U.S. Government during its Chapter 11 bankruptcy in relation to the Tar Creek site, the Cherokee County Superfund Site in southeast Kansas, the Oronogo-Duenweg Lead Mining Belt Superfund Site in Jasper County, Missouri and the Newton County Mine Tailing Site in Newton County, Missouri. NL has denied liability and will defend vigorously against all of the claims. In the second quarter of 2012, NL filed a motion to stay the case. In the first quarter of 2013, NL's motion was granted and the court entered an indefinite stay. In the first quarter of 2015, Asarco was granted permission to seek an interlocutory appeal of that stay order. In March 2015, the Eighth Circuit Court of Appeals denied Asarco's request for an interlocutory appeal of the stay order and the trial court's indefinite stay remains in place.

In September 2011, NL was served in *ASARCO LLC v. NL Industries, Inc., et al.* (United States District Court, Eastern District of Missouri, Case No. 4:11-cv-00864). The plaintiff brought this CERCLA contribution action against several defendants to recover a portion of the amount it paid in settlement with the U.S. Government during its Chapter 11 bankruptcy in relation to the Southeast Missouri Mining District. In May 2015, the trial court on its own motion entered an indefinite stay of the litigation. In June 2015, Asarco filed an appeal of the stay in the Eighth Circuit Court of Appeals. NL has moved to dismiss that appeal as improperly filed. In October 2015, the Eighth Circuit Court of Appeals granted NL's motion to dismiss Asarco's appeal and the trial court's indefinite stay remains in place.

In July 2012, NL was served in *EPEC Polymers, Inc., v. NL Industries, Inc.*, (United States District Court for the District of New Jersey, Case 3:12-cv-03842-PGS-TJB). The plaintiff, a landowner of property located across the Raritan River from NL's former Sayreville, New Jersey operation, claims that contaminants from NL's former Sayreville operation came to be located on its land. The complaint seeks compensatory and punitive damages and alleges, among other things, trespass, private nuisance, negligence, strict liability, and claims under CERCLA and the New Jersey Spill Act. In April 2016, the case was stayed and administratively terminated pending court-ordered mediation. In October 2017, the parties informed the court that further mediation would not be fruitful. The case was reopened in December 2017. NL will continue to deny liability and defend vigorously against all of the claims.

In September 2013, EPA issued to NL and 34 other PRPs general notice of potential liability and a demand for payment of past costs and performance of a Remedial Design for the Gowanus Canal Superfund Site in Brooklyn, New York. In March 2014, EPA issued a UAO to NL and approximately 27 other PRPs for performance of the Remedial Design at the site. EPA contends that NL is liable as the alleged successor to the Doehler Die Casting Company, and therefore responsible for any potential contamination at the site resulting from Doehler's ownership/operation of a warehouse and a die casting plant it owned 90 years ago. In April 2019, EPA issued a second UAO to NL and approximately 27 other PRPs for performance of certain work related to the Remedial Design at the site. NL believes that it has no liability at the site. NL is currently in discussions with EPA regarding a *de minimis* settlement and is otherwise taking actions necessary to respond to the UAO. If these discussions are unsuccessful, NL will continue to deny liability and will defend vigorously against all of the claims.

In August 2017, NL was served in *Refined Metals Corporation v. NL Industries, Inc.*, (United States District Court for the Southern District of Indiana, Case 1:17-cv-2565). This is a CERCLA and state law contribution action brought by the current owner of a former secondary lead smelting facility located in Beech Grove, Indiana. NL intends to deny liability and will defend vigorously against all claims. In September 2018, the court dismissed the case, holding that all federal claims brought against NL were barred by the statute of limitations and finding that the court lacked jurisdiction to consider the state law claims. In October 2019, Refined Metals filed a new complaint against NL alleging only state law claims. NL will continue to deny liability and will vigorously defend against all claims in the court of appeals.

In January 2020, we were sued in *Atlantic Richfield, Co. v. NL Industries, Inc.*, (United States District Court for the District of Colorado, Case 1:20-cv-00234). This is a CERCLA cost recovery action brought by a past owner and operator of certain mining properties located in Rico, Colorado. We intend to deny liability and will defend vigorously against all claims.

## ***Other Litigation***

NL— NL has been named as a defendant in various lawsuits in several jurisdictions, alleging personal injuries as a result of occupational exposure primarily to products manufactured by our former operations containing asbestos, silica and/or mixed dust. In addition, some plaintiffs allege exposure to asbestos from working in various facilities previously owned and/or operated by NL. There are 108 of these types of cases pending, involving a total of approximately 583 plaintiffs. In addition, the claims of approximately 8,715 plaintiffs have been administratively dismissed or placed on the inactive docket in Ohio courts. We do not expect these claims will be re-opened unless the plaintiffs meet the courts' medical criteria for asbestos-related claims. We have not accrued any amounts for this litigation because of the uncertainty of liability and inability to reasonably estimate the liability, if any. To date, NL has not been adjudicated liable in any of these matters. Based on information available to us, including:

- facts concerning historical operations,
- the rate of new claims,
- the number of claims from which NL has been dismissed, and
- its prior experience in the defense of these matters,

We believe that the range of reasonably possible outcomes of these matters will be consistent with NL's historical costs (which are not material). Furthermore, we do not expect any reasonably possible outcome would involve amounts material to our consolidated financial position, results of operations or liquidity. NL has sought and will continue to vigorously seek, dismissal and/or a finding of no liability from each claim. In addition, from time to time, we have received notices regarding asbestos or silica claims purporting to be brought against former subsidiaries, including notices provided to insurers with which it has entered into settlements extinguishing certain insurance policies. These insurers may seek indemnification from NL.

*Other*—In addition to the matters described above, we and our affiliates are also involved in various other environmental, contractual, product liability, patent (or intellectual property), employment and other claims and disputes incidental to present and former businesses. In certain cases, we have insurance coverage for these items, although we do not expect additional material insurance coverage for environmental claims. We currently believe that the disposition of all of these various other claims and disputes (including asbestos related claims), individually or in the aggregate, should not have a material adverse effect on our consolidated financial position, results of operations or liquidity beyond the accruals already provided.

## ***Insurance Coverage Claims—NL***

NL is involved in certain legal proceedings with a number of its former insurance carriers regarding the nature and extent of the carriers' obligations to NL under insurance policies with respect to certain lead pigment and asbestos lawsuits. The issue of whether insurance coverage for defense costs or indemnity or both will be found to exist for NL's lead pigment and asbestos litigation depends upon a variety of factors and we cannot assure you that such insurance coverage will be available.

NL has agreements with certain of its former insurance carriers pursuant to which the carriers reimburse it for a portion of its future lead pigment litigation defense costs, and one such carrier reimburses NL for a portion of its future asbestos litigation defense costs. We are not able to determine how much NL will ultimately recover from these carriers for defense costs incurred by NL because of certain issues that arise regarding which defense costs qualify for reimbursement. While NL continues to seek additional insurance recoveries, we do not know if it will be successful in obtaining reimbursement for either defense costs or indemnity. Accordingly, we recognize insurance recoveries in income only when receipt of the recovery is probable and we are able to reasonably estimate the amount of the recovery.

In January 2014, NL was served with a complaint in *Certain Underwriters at Lloyds, London, et al v. NL Industries, Inc.* (Supreme Court of the State of New York, County of New York, Index No. 14/650103). The plaintiff, a former insurance carrier of NL, is seeking a declaratory judgment of its obligations to NL under insurance policies issued to NL by the plaintiff with respect to certain lead pigment lawsuits. Other insurers have been added as parties to the case and have also sought a declaratory judgment regarding their obligations under certain insurance policies. NL has filed a counterclaim seeking a declaratory judgment that all of the insurers are obligated to provide NL with certain coverage and seeking damages for breach of contract. The case is now proceeding in the trial court. We believe the insurers' claims are without merit and NL intends to defend its rights and prosecute its claims in this action vigorously.

NL has settled insurance coverage claims concerning environmental claims with certain of its principal former carriers. We do not expect further material settlements relating to environmental remediation coverage.

## **ITEM 4. MINE SAFETY DISCLOSURES**

Not applicable.



## PART II

### ITEM 5. MARKET FOR REGISTRANT'S COMMON EQUITY, RELATED STOCKHOLDER MATTERS AND ISSUER PURCHASES OR EQUITY SECURITIES

*Common Stock and Dividends*—Our common stock is listed and traded on the New York Stock Exchange (symbol: VHI). As of February 28, 2020, there were approximately 1,700 holders of record of our common stock.

*Performance Graph*—Set forth below is a line graph comparing the yearly change in our cumulative total stockholder return on our common stock against the cumulative total return of the S&P 500 Composite Stock Price Index and the S&P 500 Industrial Conglomerates Index for the period from December 31, 2014 through December 31, 2019. The graph shows the value at December 31 of each year assuming an original investment of \$100 at December 31, 2014, and assumes the reinvestment of our regular quarterly dividends in shares of our stock.

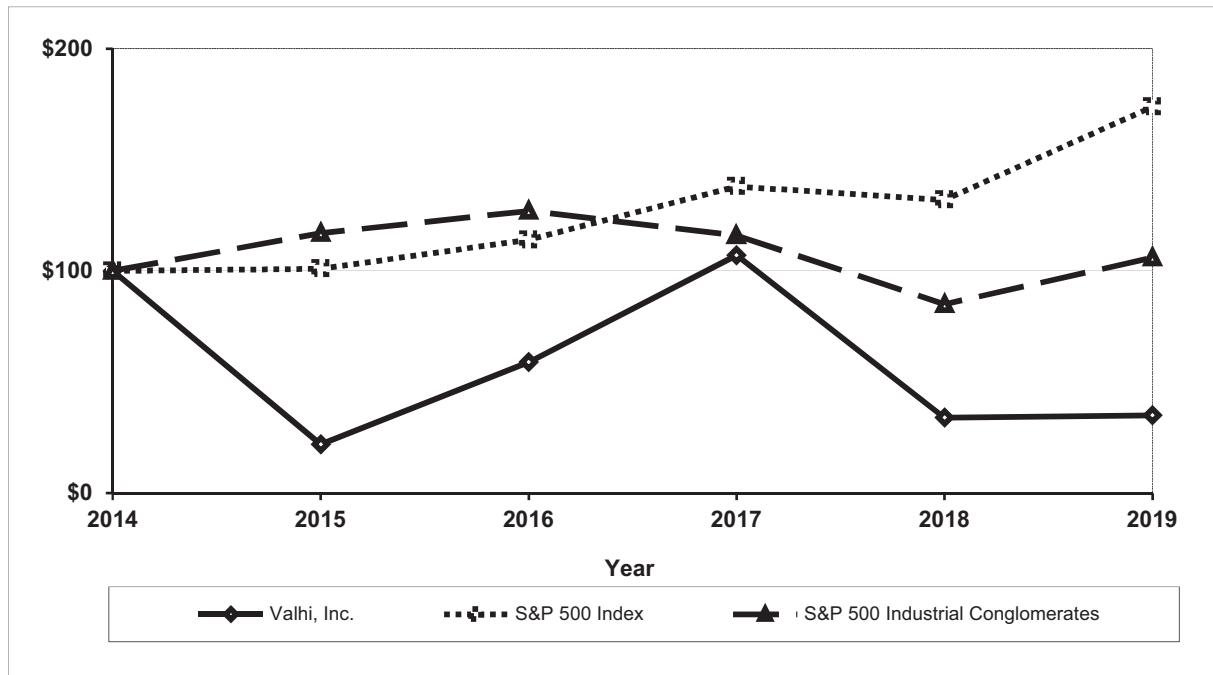

	December 31,					
	2014	2015	2016	2017	2018	2019
Valhi common stock	\$ 100	\$ 22	\$ 59	\$ 107	\$ 34	\$ 35
S&P 500 Composite Stock Price Index	100	101	114	138	132	174
S&P 500 Industrial Conglomerates Index	100	117	127	116	85	106

The information contained in the performance graph shall not be deemed “soliciting material” or “filed” with the SEC, or subject to the liabilities of Section 18 of the Securities Exchange Act, as amended, except to the extent we specifically request that the material be treated as soliciting material or specifically incorporate this performance graph by reference into a document filed under the Securities Act or the Securities Exchange Act.

*Equity Compensation Plan Information*—We have an equity compensation plan, which was approved by our stockholders, pursuant to which an aggregate of 200,000 shares of our common stock can be awarded to members of our board of directors. At December 31, 2019, an aggregate of 74,000 shares were available for future award under this plan. See Note 16 to our Consolidated Financial Statements.

*Treasury Stock Purchases*—In March 2005, our board of directors authorized the repurchase of up to 5.0 million shares of our common stock in open market transactions, including block purchases, or in privately negotiated transactions, which may include transactions with our affiliates. In November 2006, our board of directors authorized the repurchase of an additional 5.0 million shares. We may purchase the stock from time to time as market conditions permit. The stock repurchase program does not include specific price targets or timetables and may be suspended at any time. Depending on market conditions, we could terminate the program prior to completion. We will use our cash on hand to acquire the shares. Repurchased shares will be retired and cancelled or

may be added to our treasury stock and used for employee benefit plans, future acquisitions or other corporate purposes. See Note 16 to our Consolidated Financial Statements.

## ITEM 6. SELECTED FINANCIAL DATA

The following selected financial data should be read in conjunction with our Consolidated Financial Statements and related Notes and Item 7—“*Management’s Discussion and Analysis of Financial Condition and Results of Operations.*”

	Years ended December 31,				
	2015	2016	2017	2018	2019
	(In millions, except per share data)				
<b>STATEMENTS OF OPERATIONS DATA:</b>					
Net sales:					
Chemicals	\$ 1,348.8	\$ 1,364.3	\$ 1,729.0	\$ 1,661.9	\$ 1,731.2
Component products	109.0	108.9	112.0	118.2	124.2
Real estate management and development	30.1	46.2	38.4	40.0	42.1
Total net sales	<u>\$ 1,487.9</u>	<u>\$ 1,519.4</u>	<u>\$ 1,879.4</u>	<u>\$ 1,820.1</u>	<u>\$ 1,897.5</u>
Operating income:					
Chemicals <sup>(2)</sup>	\$ 19.2	\$ 102.8	\$ 358.5	\$ 342.9	\$ 160.1
Component products	14.0	15.6	15.2	17.8	17.8
Real estate management and development	-	.8	6.6	10.0	14.8
Total operating income	<u>\$ 33.2</u>	<u>\$ 119.2</u>	<u>\$ 380.3</u>	<u>\$ 370.7</u>	<u>\$ 192.7</u>
Net income (loss)	<u>\$ (171.1)</u>	<u>\$ (3.0)</u>	<u>\$ 302.6</u>	<u>\$ 301.0</u>	<u>\$ 78.2</u>
Amounts attributable to Valhi stockholders:					
Income (loss) from continuing operations	\$ (111.9)	\$ 8.1	\$ 316.7	\$ 228.1	\$ 49.2
Income (loss) from discontinued operations <sup>(1)</sup>	(21.7)	(24.0)	(109.2)	34.1	-
Net income (loss)	<u>\$ (133.6)</u>	<u>\$ (15.9)</u>	<u>\$ 207.5</u>	<u>\$ 262.2</u>	<u>\$ 49.2</u>
<b>DILUTED EARNINGS PER SHARE DATA:</b>					
Net income (loss) attributable to Valhi stockholders:					
Income (loss) from continuing operations	\$ (.33)	\$ .02	\$ .93	\$ .67	\$ .14
Income (loss) from discontinued operations <sup>(1)</sup>	(.06)	(.07)	(.32)	.10	-
Net income (loss)	<u>\$ (.39)</u>	<u>\$ (.05)</u>	<u>\$ .61</u>	<u>\$ .77</u>	<u>\$ .14</u>
Cash dividends	\$ .08	\$ .08	\$ .08	\$ .08	\$ .08
Weighted average common shares outstanding	342.0	342.0	342.0	342.0	342.1
<b>STATEMENTS OF CASH FLOW DATA:</b>					
Cash provided by (used in):					
Operating activities	\$ 22.1	\$ 79.8	\$ 259.3	\$ 165.5	\$ 177.2
Investing activities	(54.1)	(61.6)	(74.4)	(57.0)	(50.7)
Financing activities	(10.6)	(45.5)	93.6	(59.8)	(64.1)
<b>BALANCE SHEET DATA (at year end):</b>					
Total assets <sup>(3)</sup>	\$ 2,537.4	\$ 2,443.2	\$ 2,907.5	\$ 2,709.6	\$ 2,794.4
Long-term debt <sup>(4)</sup>	879.7	889.3	1,041.5	797.5	789.4
Valhi stockholders' equity	268.7	200.9	424.4	635.4	640.0
Total equity	526.9	444.4	766.7	989.0	980.1

(1) In January 2018 we completed the sale of our Waste Management Segment. The results of operations of our Waste Management Segment have been reclassified as discontinued operations in our Consolidated Statements of Operations for the years ended December 31, 2015, 2016, 2017 and 2018. See Note 3 to our Consolidated Financial Statements.

(2) Prior period amounts have been reclassified to reflect the adoption on January 1, 2018 of ASU 2017-07, *Compensation – Retirement Benefits (Topic 715) Improving the Presentation of Net Periodic Pension Cost and Net Periodic Postretirement Benefit Cost*. As a result, Chemicals Segment operating income increased by \$12.1 million, \$11.8 million and \$17.4 million in 2015, 2016 and 2017, respectively. There was no impact to net income (loss) in any period as a result of this reclassification.

(3) On January 1, 2019 we adopted ASU 2016-02, *Leases (Topic 842)*. Our December 31, 2019 total assets include \$29.0 million of right-of-use leased assets. Prior periods were not restated.

(4) Excludes any indebtedness of our Waste Management Segment. The assets and liabilities of our Waste Management Segment have been reclassified as discontinued operations in our Consolidated Balance Sheet at December 31, 2015, 2016 and 2017.

## ITEM 7. MANAGEMENT'S DISCUSSION AND ANALYSIS OF FINANCIAL CONDITION AND RESULTS OF OPERATIONS

### RESULTS OF OPERATIONS

#### Business Overview

We are primarily a holding company. We operate through our wholly-owned and majority-owned subsidiaries, including NL Industries, Inc., Kronos Worldwide, Inc., CompX International, Inc., Tremont LLC, Basic Management, Inc. ("BMI") and the LandWell Company ("LandWell"). Kronos (NYSE: KRO), NL (NYSE: NL) and CompX (NYSE American: CIX) each file periodic reports with the SEC.

On January 26, 2018 we completed the sale of our Waste Management Segment to JFL-WCS Partners, LLC ("JFL Partners"), an entity sponsored by certain investment affiliates of J.F. Lehman & Company, for consideration consisting of the assumption of all of WCS' third-party indebtedness and other liabilities. Accordingly the results of operations of our Waste Management Segment is reflected as discontinued operations in our Consolidated Statements of Income for the years ended December 31, 2017 and 2018. We recognized a pre-tax gain of approximately \$58 million on the transaction in the first quarter of 2018 because the carrying value of the liabilities of the business assumed by the purchaser exceeded the carrying value of the assets sold at the time of sale in large part due to a long-lived asset impairment of \$170.6 million recognized with respect to the Waste Management Segment in the second quarter of 2017. Such pre-tax gain is classified as part of discontinued operations. Our Waste Management Segment, which operated in the low-level radioactive, hazardous, toxic and other waste disposal industry historically struggled to generate sufficient recurring disposal volumes to generate positive operating results or cash flows. The sale enabled us to focus more effort on continuing to develop our remaining segments which we believe have greater opportunity for higher returns. See Note 3 to our Consolidated Financial Statements.

We have three consolidated reportable operating segments:

- *Chemicals*—Our Chemicals Segment is operated through our majority control of Kronos. Kronos is a leading global producer and marketer of value-added TiO<sub>2</sub>. TiO<sub>2</sub> is used to impart whiteness, brightness, opacity and durability to a wide variety of products, including paints, plastics, paper, fibers and ceramics. Additionally, TiO<sub>2</sub> is a critical component of everyday applications, such as coatings, plastics and paper, as well as many specialty products such as inks, foods and cosmetics.
- *Component Products*—We operate in the component products industry through our majority control of CompX. CompX is a leading manufacturer of security products used in the recreational transportation, postal, office and institutional furniture, cabinetry, tool storage, healthcare and a variety of other industries. CompX also manufactures stainless steel exhaust systems, gauges, throttle controls, wake enhancements systems and trim tabs for the recreational marine and other industries.
- *Real Estate Management and Development*—We operate in real estate management and development through our majority control of BMI and LandWell. BMI provides utility services to certain industrial and municipal customers and owns real property in Henderson, Nevada. LandWell is engaged in efforts to develop certain land holdings for commercial, industrial and residential purposes in Henderson, Nevada.

#### Income (Loss) from Continuing Operations Overview

*Year Ended December 31, 2019 Compared to Year Ended December 31, 2018—*

We reported net income from continuing operations attributable to Valhi stockholders of \$49.2 million or \$.14 per diluted share in 2019 compared to \$228.1 million or \$.67 per diluted share in 2018.

Our net income from continuing operations attributable to Valhi stockholders decreased from 2018 to 2019 primarily due to the net effects of:

- the recognition of an aggregate non-cash deferred income tax benefit of \$112 million in 2018 related to a change in the deferred income tax liability related to our investment in Kronos, net of the revaluation of such change resulting from the reduction in the U.S. federal corporate income tax rate as a result of the 2017 Tax Act;
- lower operating income from our Chemicals Segment in 2019 compared to 2018;
- a pre-tax litigation settlement expense of \$19.3 million recognized in 2019 compared to \$62.0 million recognized in 2018;

- a securities transaction gain of \$12.5 million recognized in 2018 related to the sale of our interest in Amalgamated Sugar Company LLC (“Amalgamated”);
- the recognition of a gain on sale of land of \$4.4 million in 2019 compared to \$12.5 million recognized in 2018;
- income from tax increment infrastructure reimbursement of \$8.8 million in 2019 compared to \$3.1 million in 2018;
- insurance recoveries of \$7.7 million in 2019 compared to \$1.3 million in 2018;
- a gain of \$3.0 million in 2019 related to the sale of our insurance and risk management business;
- lower interest expense in 2019 as a result of the deemed repayment of the Snake River debt in August 2018;
- lower dividend and interest income in 2019 as a result of the deemed redemption of our investment in the Amalgamated Sugar Company in August 2018; and
- lower litigation fees and related costs in 2019.

Our net diluted income from continuing operations per share in 2019 includes:

- a charge of \$.04 per diluted share related to the litigation settlement expense recognized;
- a gain of \$.01 per diluted share related to tax increment infrastructure reimbursement;
- a gain of \$.01 per diluted share related to insurance recoveries;
- a gain of \$.01 per diluted share related to the sale of land not used in our operations; and
- a gain of \$.01 per diluted share related to the sale of our insurance and risk management business.

Our net diluted income from continuing operations per share in 2018 includes:

- a non-cash deferred income tax benefit of \$.33 per diluted share related to a change in the deferred income tax liability related to our investment in Kronos as a result of the 2017 Tax Act;
- a gain of \$.03 per diluted share related to a securities transaction gain related to the sale of our interest in Amalgamated;
- a gain of \$.03 per diluted share related to the sale of land not used in our operations;
- a charge of \$.12 per diluted share related to the litigation settlement expense recognized; and
- a charge of \$.01 per diluted share current cash income tax expense recognized related to GILTI.

We discuss these amounts more fully below.

*Year Ended December 31, 2018 Compared to Year Ended December 31, 2017—*

We reported net income from continuing operations attributable to Valhi stockholders of \$228.1 million or \$.67 per diluted share in 2018 compared to \$316.7 million or \$.93 per diluted share in 2017.

Our net income from continuing operations attributable to Valhi stockholders decreased from 2017 to 2018 primarily due to the net effects of:

- the recognition of an aggregate non-cash deferred income tax benefit of \$112 million in 2018 related to a change in the deferred income tax liability related to our investment in Kronos, net of the revaluation of such change resulting from the reduction in the U.S. federal corporate income tax rate as a result of the 2017 Tax Act;
- the recognition of an aggregate non-cash deferred income tax benefit of \$186.7 million in 2017 as a result of a decrease in our deferred income tax asset valuation allowance related to our Chemicals Segment’s German and Belgian operations;
- a pre-tax litigation settlement expense of \$62.0 million recognized in 2018;
- a securities transaction gain of \$12.5 million recognized in 2018 related to the sale of our interest in Amalgamated;
- recognition of a gain on sale of land of \$12.5 million in 2018;
- an aggregate charge of \$7.1 million recognized in 2017 related to the loss on prepayment of debt;
- lower operating income from our Chemicals Segments in 2018 compared to 2017 somewhat offset by higher operating income at our other segments (Component Products and Real Estate Management and Development);

- the fourth quarter 2018 recognition of a \$4.0 million current cash income tax expense related to tax on global intangible low-tax income (“GILTI”);
- the fourth quarter 2017 recognition of an \$18.7 million non-cash deferred income tax benefit as a result of the reversal of our deferred income tax asset valuation allowance related to certain U.S. deferred income tax assets of one of our non-U.S. subsidiaries (which subsidiary is treated as a dual resident for U.S. income tax purposes);
- the recognition of an \$11.8 million aggregate income tax benefit in 2017 related to the execution and finalization of an Advance Pricing Agreement (“APA”) between Canada and Germany, mostly recognized in the third quarter (which includes an \$8.6 million non-cash income tax benefit as a result of a net decrease in our reserve for uncertain tax positions);
- the fourth quarter 2017 recognition of a \$76.2 million provisional current income tax expense as a result of the 2017 Tax Act for the one-time repatriation tax imposed on the post-1986 undistributed earnings of our non-U.S. subsidiaries;
- the fourth quarter 2017 recognition of a \$77.1 million non-cash deferred income tax benefit related to the revaluation of our net deferred income tax liability resulting from the reduction in the U.S. federal corporate income tax rate enacted as part of the 2017 Tax Act; and
- 2017 recognition of a \$5.3 million provisional non-cash deferred income tax expense related to a change in our conclusions regarding our permanent reinvestment assertion with respect to the post-1986 undistributed earnings of our European subsidiaries.

Our net diluted income from continuing operations per share in 2018 includes:

- a non-cash deferred income tax benefit of \$.33 per diluted share related to a change in the deferred income tax liability related to our investment in Kronos as a result of the 2017 Tax Act;
- a gain of \$.03 per diluted share related to a securities transaction gain related to the sale of our interest in Amalgamated;
- a gain of \$.03 per diluted share related to the sale of land not used in our operations;
- a charge of \$.12 per diluted share related to the litigation settlement expense recognized;
- a charge of \$.01 per diluted share current cash income tax expense recognized related to GILTI.

Our net diluted income from continuing operations per share in 2017 includes:

- a \$.32 per diluted share non-cash deferred income tax benefit as a result of the reversal of our deferred income tax asset valuation allowances associated with our German and Belgian operations, mostly recognized in the second quarter;
- a \$.03 per diluted share non-cash deferred income tax benefit as a result of the reversal of our deferred income tax asset valuation allowance related to certain U.S. deferred income tax assets of one of our non-U.S. subsidiaries (which subsidiary is treated as a dual resident for U.S. income tax purposes) recognized in the fourth quarter;
- a \$.02 per diluted share income tax benefit related to the execution and finalization of an APA between Canada and Germany, mostly recognized in the third quarter;
- a \$.13 per diluted share provisional current income tax expense as a result of the 2017 Tax Act for the one-time repatriation tax imposed on the post-1986 undistributed earnings of our non-U.S. subsidiaries recognized in the fourth quarter;
- a \$.22 per diluted share non-cash deferred income tax benefit related to the revaluation of our net deferred income tax liability resulting from the reduction in the U.S. federal corporate income tax rate enacted as part of the 2017 Tax Act;
- a \$.01 per diluted share provisional non-cash deferred income tax expense related to a change in our conclusions regarding our permanent reinvestment assertion with respect to the post-1986 undistributed earnings of our European subsidiaries recognized in the fourth quarter; and
- an aggregate charge of \$.01 per diluted share recognized in the third quarter related to the loss on prepayment of debt.

We discuss these amounts more fully below.

#### *Current Forecast for 2020—*

We currently expect to report lower consolidated operating income for 2020 as compared to 2019 primarily due to the net effects of:

- lower operating income from our Chemicals Segment in 2020 due to the unfavorable impact of lower expected sales volumes and higher raw material costs (principally feedstock ore) in 2020; and
- higher operating income from our Real Estate Management and Development Segment in 2020 as we anticipate increased tax infrastructure reimbursement and increased land development activities.

Our expectations for our future operating results are based upon a number of factors beyond our control, including worldwide growth of gross domestic product, competition in the marketplace, continued operation of competitors, technological advances, worldwide production capacity and the consequences arising directly or indirectly out of the recent coronavirus outbreak. The extent of the impact of the coronavirus outbreak on our operational and financial performance will depend on future developments, including the severity, duration and spread of the outbreak and its impact on, among other things, overall demand for our products and our customers' products, supply chains, our operations and the operations of our competitors, all of which are uncertain and cannot be predicted. If actual developments differ from our expectations, our results of operations could be unfavorably affected.

#### *Segment Operating Results—2019 Compared to 2018 and 2018 Compared to 2017*

##### **Chemicals—**

We consider TiO<sub>2</sub> to be a “quality of life” product, with demand affected by gross domestic product, or GDP, and overall economic conditions in our markets located in various regions of the world. Over the long-term, we expect demand for TiO<sub>2</sub> will grow by 2% to 3% per year, consistent with our expectations for the long-term growth in GDP. However, even if we and our competitors maintain consistent shares of the worldwide market, demand for TiO<sub>2</sub> in any interim or annual period may not change in the same proportion as the change in GDP, in part due to relative changes in the TiO<sub>2</sub> inventory levels of our customers. We believe that our customers' inventory levels are influenced in part by their expectation for future changes in TiO<sub>2</sub> selling prices as well as their expectation for future availability of product. Although certain of our TiO<sub>2</sub> grades are considered specialty pigments, the majority of our grades and substantially all of our production are considered commodity pigment products with price and availability being the most significant competitive factors along with product quality and customer and technical support services.

The factors having the most impact on our reported operating results are:

- TiO<sub>2</sub> selling prices,
- Our TiO<sub>2</sub> sales and production volumes,
- Manufacturing costs, particularly raw materials such as third-party feedstock ore, maintenance and energy-related expenses, and
- Currency exchange rates (particularly the exchange rate for the U.S. dollar relative to the euro, the Norwegian krone and the Canadian dollar).

Our key performance indicators are our TiO<sub>2</sub> average selling prices, our level of TiO<sub>2</sub> sales and production volumes and the cost of our third-party feedstock ore. TiO<sub>2</sub> selling prices generally follow industry trends and selling prices will increase or decrease generally as a result of competitive market pressures.

	Years ended December 31,			% Change	
	2017	2018	2019	2017-18	2018-19
	(Dollars in millions)				
Net sales	\$ 1,729.0	\$ 1,661.9	\$ 1,731.2	(4)%	4%
Cost of sales	1,161.2	1,101.7	1,346.8	(5)%	22%
Gross margin	\$ 567.8	\$ 560.2	\$ 384.4	(1)%	(31)%
Operating income	\$ 358.5	\$ 342.9	\$ 160.1	(4)%	(53)%
Percent of net sales:					
Cost of sales	67%	66%	78%		
Gross margin	33%	34%	22%		
Operating income	21%	21%	9%		
TiO <sub>2</sub> operating statistics:					
Sales volumes*	586	491	566	(16)%	15%
Production volumes*	576	536	546	(7)	2
Production rate as percent of capacity	100%	95%	98%		
Percent change in TiO <sub>2</sub> net sales:					
TiO <sub>2</sub> product pricing				13%	(6)%
TiO <sub>2</sub> sales volumes				(16)	15
TiO <sub>2</sub> product mix/other				(4)	(2)
Changes in currency exchange rates				3	(3)
Total				(4)%	4%

\* Thousands of metric tons

*Industry Conditions and 2019 Overview* – At the beginning of 2019, our Chemicals Segment’s average TiO<sub>2</sub> selling prices were 3% lower than at the beginning of 2018 and from that point, average selling prices, though lower than 2018 selling prices, were relatively stable throughout 2019. Our Chemicals Segment’s average selling prices at the end of the fourth quarter of 2019 were 1% lower than at the end of the third quarter of 2019 and 1% lower than at the end of 2018. We experienced higher sales volumes in the European, North American and export markets in 2019 as compared to sales volumes in 2018, with the European market experiencing the most significant increase.

The following table shows our capacity utilization rates during 2018 and 2019.

	2018	2019
First Quarter	95%	97%
Second Quarter	97%	97%
Third Quarter	92%	97%
Fourth Quarter	95%	100%
Overall	95%	98%

Primarily due to a moderate rise in the cost of third-party feedstock we procured in 2018 and 2019, our cost of sales per metric ton of TiO<sub>2</sub> sold in 2019 was higher as compared to 2018 (excluding the effect of changes in currency exchange rates).

*Net sales* – Our Chemicals Segment’s net sales increased 4% or \$69.2 million in 2019 compared to 2018, primarily due to the net effect of a 6% decrease in average TiO<sub>2</sub> selling prices (which decreased net sales by approximately \$100 million), a 15% increase in sales volumes (which increased net sales by approximately \$249 million) and changes in currency exchange rates. TiO<sub>2</sub> selling prices will increase or decrease generally as a result of competitive market pressures, changes in the relative level of supply and demand as well as changes in raw material and other manufacturing costs. Our Chemicals Segment’s sales volumes increased 15% in 2019 as compared to the sales volumes of 2018 primarily due to strength in the European, North American and export markets in 2019 as compared to 2018. In addition to the impact of changes in average TiO<sub>2</sub> selling prices and sales volumes, we estimate that changes in currency exchange rates decreased our net sales by approximately \$49 million, or 3%, as compared to 2018.

Our Chemicals Segment's net sales decreased 4% or \$67.1 million in 2018 compared to 2017, primarily due to the net effect of a 13% increase in average TiO<sub>2</sub> selling prices (which increased net sales by approximately \$225 million) and a 16% decrease in sales volumes (which decreased net sales by approximately \$277 million). TiO<sub>2</sub> selling prices will increase or decrease generally as a result of competitive market pressures, changes in the relative level of supply and demand as well as changes in raw material and other manufacturing costs.

Our Chemicals Segment's sales volumes decreased 16% in 2018 as compared to the record sales volumes of 2017 primarily due to a combination of factors including (i) lower sales in all major markets resulting from a controlled ramp-up in January 2018 as we brought the second phase of our new global enterprise resource planning system online; (ii) inventory management to assure adequate supply to our customers during the spring and summer necessitated by the lower production volumes in the first three months of the year (as discussed below); (iii) product availability in the second quarter; and (iv) customer inventory level changes in the second, third and fourth quarters as customer inventory levels returned to more normal levels. In addition to the impact of changes in average TiO<sub>2</sub> selling prices and sales volumes, we estimate that changes in currency exchange rates increased our net sales by approximately \$49 million, or 3%, as compared to 2017.

*Cost of Sales and Gross Margin*— Our Chemicals Segment's cost of sales increased \$245.2 million or 22% in 2019 compared to 2018 primarily due to the net impact of a 15% increase in sales volumes, higher raw materials and other production costs of approximately \$122 million (including higher cost for third-party feedstock, energy and other raw materials) and currency fluctuations (primarily the euro relative to the U.S. dollar). Our Chemicals Segment's cost of sales as a percentage of net sales increased to 78% in 2019 compared to 66% in 2018 primarily due to the unfavorable effects of lower average selling prices and higher raw materials and other production costs, as discussed above.

Gross margin as a percentage of net sales decreased to 22% in 2019 compared to 34% in 2018. As discussed and quantified above, our gross margin decreased primarily due to the net effect of lower average selling prices, higher sales volumes and higher raw materials and other production costs.

Our Chemicals Segment's cost of sales decreased 5% in 2018 compared to 2017 due to the net impact of a 16% decrease in sales volumes, a 7% decrease in TiO<sub>2</sub> production volumes, higher raw materials and other production costs of approximately \$103 million (primarily caused by higher third-party feedstock ore costs) and currency fluctuations (primarily the euro). The decrease in TiO<sub>2</sub> production volumes in 2018 compared to the production volumes in 2017 was primarily due to increased maintenance activities at certain facilities in 2018, and the implementation of a productivity-enhancing improvement project at our Belgian facility in the first quarter of 2018. Our Chemicals Segment's cost of sales as a percentage of net sales decreased to 66% in 2018 compared to 67% in 2017 as the favorable effects of higher average selling prices more than offset the unfavorable effects related to lower production volumes and higher raw materials and other production costs, as discussed above.

Gross margin as a percentage of net sales increased to 34% in 2018 compared to 33% in 2017. As discussed and quantified above, our gross margin increased primarily due to the net effect of higher average selling prices, lower sales and production volumes and higher raw materials and other production costs.

*Operating Income*— Our Chemicals Segment's operating income decreased 53% in 2019 compared to 2018 and operating income as a percentage of net sales decreased to 9% in 2019 from 21% in 2018. This decrease was driven by the decrease in gross margin discussed above for the comparable periods. We estimate that changes in currency exchange rates decreased operating income by approximately \$3 million in 2019 as compared to 2018.

Our Chemicals Segment's operating income decreased 4% in 2018 compared to 2017 and operating income as a percentage of net sales was flat at 21% in 2018 and 2017. This decrease was in part due to higher general and administrative costs related to the implementation of a new accounting and manufacturing software system of \$11 million, higher shipping and handling costs of \$4 million and higher sales support costs of \$3 million to better serve our customers. We estimate that changes in currency exchange rates increased our Chemicals Segment's operating income by approximately \$33 million in 2018 as compared to 2017.

Our Chemicals Segment's operating income is net of amortization of purchase accounting adjustments made in conjunction with our acquisitions of interests in NL and Kronos. As a result, we recognize additional depreciation expense above the amounts Kronos reports separately, substantially all of which is included within cost of sales. We recognized additional depreciation expense of \$2.2 million in 2017, \$2.3 million in 2018 and \$2.2 million in 2019, which reduced our reported Chemicals Segment's operating income (loss) as compared to amounts reported by Kronos.

*Currency Exchange Rates*— Our Chemicals Segment has substantial operations and assets located outside the United States (primarily in Germany, Belgium, Norway and Canada). The majority of our Chemicals Segment's sales from non-U.S. operations are denominated in currencies other than the U.S. dollar, principally the euro, other major European currencies and the Canadian dollar. A portion of our sales generated from our non-U.S. operations is denominated in the U.S. dollar (and consequently our non-U.S.



operations will generally hold U.S. dollars from time to time). Certain raw materials used in all our production facilities, primarily titanium-containing feedstocks, are purchased primarily in U.S. dollars, while labor and other production costs are purchased primarily in local currencies. Consequently, the translated U.S. dollar value of our non-U.S. sales and operating results are subject to currency exchange rate fluctuations which may favorably or unfavorably impact reported earnings and may affect the comparability of period-to-period operating results. In addition to the impact of the translation of sales and expenses over time, our non-U.S. operations also generate currency transaction gains and losses which primarily relate to (i) the difference between the currency exchange rates in effect when non-local currency sales or operating costs (primarily U.S. dollar denominated) are initially accrued and when such amounts are settled with the non-local currency, (ii) changes in currency exchange rates during time periods when our non-U.S. operations are holding non-local currency (primarily U.S. dollars), and (iii) relative changes in the aggregate fair value of currency forward contracts held from time to time. As discussed in Note 19 to our Consolidated Financial Statements, we periodically use currency forward contracts to manage a portion of our currency exchange risk, and relative changes in the aggregate fair value of any currency forward contracts we hold from time to time serves in part to mitigate the currency transaction gains or losses we would otherwise recognize from the first two items described above.

Overall, we estimate that fluctuations in currency exchange rates had the following effects on our Chemicals Segment's sales and income from operations for the periods indicated.

**Impact of changes in currency exchange rates - 2019 vs. 2018**

	<b>Transaction gains/(losses) recognized</b>			<b>Translation gains/(losses) impact of rate changes</b>	<b>Total currency impact 2019 vs. 2018</b>
	<b>2018</b>	<b>2019</b>	<b>Change</b>		
	<b>(In millions)</b>				
<b>Impact on:</b>					
Net sales	\$ -	\$ -	\$ -	\$ (49)	\$ (49)
Operating income	10	2	(8)	5	(3)

The \$49 million decrease in net sales (translation loss) was caused primarily by a strengthening of the U.S. dollar relative to the euro, as our euro-denominated sales were translated into fewer U.S. dollars in 2019 as compared to 2018. The strengthening of the U.S. dollar relative to the Canadian dollar and the Norwegian krone in 2019 did not have a significant effect on the reported amount of our net sales, as a substantial portion of the sales generated by our Chemicals Segment's Canadian and Norwegian operations are denominated in the U.S. dollar.

The \$3 million decrease in operating income was comprised of the following:

- Approximately \$8 million from net currency transaction losses primarily caused by relative changes in currency exchange rates at each applicable balance sheet date between the U.S. dollar and the euro, Canadian dollar and the Norwegian krone, which causes increases or decreases, as applicable, in U.S. dollar-denominated receivables and payables and U.S. dollar currency held by our Chemicals Segment's non-U.S. operations, and
- Approximately \$5 million from net currency translation gains primarily caused by the strengthening of the U.S. dollar relative to the Canadian dollar and Norwegian krone, as its local currency-denominated operating costs were translated into fewer U.S. dollars in 2019 as compared to 2018, partially offset by the strengthening of the U.S. dollar relative to the euro as the reduction in net sales caused by such strengthening of the stronger U.S. dollar on euro-denominated sales more than offset the favorable effect of euro-denominated operating costs being translated into fewer U.S. dollars in 2019 as compared to 2018.

**Impact of changes in currency exchange rates - 2018 vs. 2017**

	<b>Transaction gains/(losses) recognized</b>			<b>Translation gains-impact of rate changes</b>	<b>Total currency impact 2018 vs. 2017</b>
	<b>2017</b>	<b>2018</b>	<b>Change</b>		
	<b>(In millions)</b>				
<b>Impact on:</b>					
Net sales	\$ -	\$ -	\$ -	\$ 49	\$ 49
Operating income	(8)	10	18	15	33

The \$49 million increase in net sales (translation gain) was caused primarily by a weakening of the U.S. dollar relative to the euro, as our Chemicals Segment's euro-denominated sales were translated into more U.S. dollars in 2018 as compared to 2017. The

weakening of the U.S. dollar relative to the Canadian dollar and the Norwegian krone in 2018 did not have a significant effect on the reported amount of our net sales, as a substantial portion of the sales generated by our Chemicals Segment's Canadian and Norwegian operations are denominated in the U.S. dollar.

The \$33 million increase in operating income was comprised of the following:

- Approximately \$18 million from net currency transaction gains primarily caused by relative changes in currency exchange rates at each applicable balance sheet date between the U.S. dollar and the euro, Canadian dollar and the Norwegian krone, which causes increases or decreases, as applicable, in U.S. dollar-denominated receivables and payables and U.S. dollar currency held by our Chemicals Segment's non-U.S. operations, and
- Approximately \$15 million from net currency translation gains primarily caused by a weakening of the U.S. dollar relative to the euro as the positive effects of the weaker U.S. dollar on euro-denominated sales more than offset the unfavorable effects of euro-denominated operating costs being translated into more U.S. dollars in 2018 as compared to 2017, partially offset by the weakening of the U.S. dollar relative to the Canadian dollar, as its local currency-denominated operating costs were translated into more U.S. dollars in 2018 as compared to 2017.

*Outlook*— During 2019 we operated our Chemicals Segment's production facilities at 98% of practical capacity compared to 95% of practical capacity in 2018. We expect our Chemicals Segment's production volumes in 2020 to be slightly higher as compared to the 2019 production volumes. Based on anticipated production levels, and assuming stable global economic conditions continue, including limited impact on our Chemicals Segment's business from the coronavirus discussed below, we expect our Chemicals Segment's 2020 sales volumes to be slightly lower as compared to 2019 sales volumes. We will continue to monitor current and anticipated near-term customer demand levels throughout the year and align our production and inventories accordingly.

The cost of third-party feedstock we purchased in the last half of 2018 and throughout 2019 was higher as compared to the first half of 2018 and such higher cost feedstock was reflected in our results of operations in 2019. Consequently, our cost of sales per metric ton of TiO<sub>2</sub> sold in 2019 was higher than our per-metric ton cost in 2018 (excluding the effect of changes in currency exchange rates). We expect our cost of sales per metric ton of TiO<sub>2</sub> sold in 2020 to be higher than our per-metric ton cost in 2019 primarily due to continued higher feedstock costs.

At the beginning of 2019, our average TiO<sub>2</sub> selling prices were 3% lower than at the beginning of 2018 and from that point, average selling prices, though lower than 2018 selling prices, were relatively stable, declining an additional 1% during 2019. Producer inventories of certain grades of TiO<sub>2</sub> remain tight, while inventories of certain other grades are adequate. Considering all of the foregoing factors, including rising raw material costs and steady demand, we expect selling prices to remain stable during the first quarter of 2020.

Overall, we expect our Chemicals Segment's sales in 2020 will be slightly lower than in 2019, principally as a result of the unfavorable impact of lower expected sales volumes. In addition, we expect our Chemicals Segment's operating income in 2020 will be lower as compared to 2019 due to the unfavorable impact of lower expected sales volumes and higher raw material costs (principally feedstock).

Our expectations for our future operating results are based upon a number of factors beyond our control, including worldwide growth of gross domestic product, competition in the marketplace, continued operation of competitors, technological advances, worldwide production capacity and the consequences arising directly or indirectly out of the recent coronavirus outbreak. The extent of the impact of the coronavirus outbreak on our Chemicals Segment's operational and financial performance will depend on future developments, including the severity, duration and spread of the outbreak and its impact on, among other things, overall demand for our Chemicals Segment's products and its customers' products, supply chains, its operations and the operations of its competitors, all of which are uncertain and cannot be predicted. If actual developments differ from our expectations, our results of operations could be unfavorably affected.

### **Component Products—**

Our Component Products Segment's product offerings consist of a large number of products that have a wide variation in selling price and manufacturing cost, which results in certain practical limitations on our ability to quantify the impact of changes in individual product sales quantities and selling prices on our net sales, cost of sales and gross margin. In addition, small variations in period-to-period net sales, cost of sales and gross margin can result from changes in the relative mix of our products sold. The key performance indicator for our Component Products Segment is operating income margins.

	Years ended December 31,			% Change	
	2017	2018	2019	2017-18	2018-19
	(Dollars in millions)				
Net sales:					
Security products	\$ 96.6	\$ 98.4	\$ 99.3	2%	1 %
Marine components	15.4	19.8	24.9	29	26
Total net sales	112.0	118.2	124.2	6	5
Cost of sales	77.2	79.9	85.2	4	7
Gross margin	\$ 34.8	\$ 38.3	\$ 39.0	10	2
Operating income	\$ 15.2	\$ 17.8	\$ 17.7	17	(1)
Percent of net sales:					
Cost of sales	69%	68%	69%		
Gross margin	31%	32%	31%		
Operating income	14%	15%	14%		

*Net Sales*—Our Component Products Segment’s net sales increased approximately \$6.0 million in 2019 compared to 2018 primarily due to higher marine component sales to the towboat market. Relative changes in selling prices did not have a material impact on net sales comparisons.

Our Component Products Segment’s net sales increased approximately \$6.2 million in 2018 compared to 2017 primarily due to higher marine component sales volumes to manufacturers of ski/wakeboard boats and larger center-console boats, and to a lesser extent higher security product sales to certain markets, particularly transportation and office furniture. Relative changes in selling prices did not have a material impact on net sales comparisons.

*Costs Sales and Gross Margin*—Our Component Products Segment’s cost of sales increased in 2019 compared to 2018 due to the effects of increased sales volumes for both the security products and marine components reporting units and increased labor costs at the security products reporting unit. As a result, gross margin as a percentage of sales decreased over the same period. The decrease in gross margin percentage is the result of the decline in gross margin percentage at the security products reporting unit in 2019 as compared to 2018.

Our Component Products Segment’s cost of sales increased from 2017 to 2018 primarily due to increased sales volumes for both security products and marine components. Gross margin dollars and gross margin as a percentage of sales increased from 2017 to 2018 primarily due to greater fixed cost leverage facilitated by higher production volumes for each of our Component Products Segment’s business units.

*Operating Income*—Our Component Products Segment operating income decreased in 2019 compared to 2018. Operating margin decreased in 2019 compared to 2018 primarily due to the factors impacting cost of sales and gross margin above. Operating costs and expenses consists primarily of sales and administrative-related personnel costs, sales commissions and advertising expenses directly related to product sales and administrative costs relating to business unit and corporate management activities, as well as gains and losses on disposal of property and equipment. Operating costs and expenses increased \$.8 million in 2019 compared to 2018.

Our Component Products Segment operating income improved in 2018 compared to 2017 primarily due to the increase in gross margin. Operating costs and expenses increased \$.9 million in 2018 compared to 2017.

*General*— Our Component Products Segment’s profitability primarily depends on our ability to utilize our production capacity effectively, which is affected by, among other things, the demand for our products and our ability to control our manufacturing costs, primarily comprised of labor costs and materials. The materials used in our Component Products Segment’s products consist of purchased components and raw materials, some of which are subject to fluctuations in the commodity markets such as zinc, brass and stainless steel. Total material costs represented approximately 45% of our Component Products Segment’s cost of sales in 2019, with commodity-related raw materials accounting for approximately 13% of our cost of sales. During 2018, markets for the primary commodity-related raw materials used in the manufacture of our locking mechanisms, primarily zinc and brass, generally strengthened, but moderated at the end of 2018 and remained relatively stable through 2019. Over that same period, the market for stainless steel, the primary raw material used for the manufacture of marine exhaust headers and pipes and wake enhancement systems, remained relatively stable. While we expect the markets for our Component Products Segment’s primary commodity-related raw materials to remain stable during 2020, we recognize that economic conditions could introduce renewed volatility on these and other manufacturing materials.

Our Component Products Segment occasionally enters into short-term commodity-related raw material supply arrangements to mitigate the impact of future increases in commodity related raw material costs. See Item 1 - “Business – Component Products Segment – CompX International, Inc. - Raw Materials.”

*Outlook*— 2019 was a breakout year for our Component Product Segment’s marine components reporting unit which sustained the significant growth experienced in the second half of 2018 and for the full year of 2019. Growth of the marine components reporting unit will be more normalized in 2020. Our Component Product Segment’s security products reporting unit experienced modest sales growth in 2019 however we began to notice headwinds late in 2019 which may carry into 2020. In 2020, we plan to capitalize on the positive momentum the marine components reporting unit has experienced over the last two years while maintaining strong results at the security products reporting unit. We will continue to monitor economic conditions and sales order rates and respond to fluctuations in customer demand through continuous evaluation of staffing levels and consistent execution of our lean manufacturing and cost improvement initiatives. Additionally, we continue to seek opportunities to gain market share in markets we currently serve, to expand into new markets and to develop new product features in order to mitigate the impact of changes in demand as well as broaden our sales base.

#### Real Estate Management and Development—

	Years ended December 31,		
	2017	2018	2019
	(In millions)		
Net sales:			
Land sales	\$ 30.2	\$ 32.3	\$ 33.5
Water delivery sales	6.0	5.6	6.8
Utility and other	2.2	2.1	1.8
Total net sales	<u>38.4</u>	<u>40.0</u>	<u>42.1</u>
Cost of sales	<u>28.1</u>	<u>29.3</u>	<u>30.8</u>
Gross margin	<u>\$ 10.3</u>	<u>\$ 10.7</u>	<u>\$ 11.3</u>
Operating income	<u>\$ 6.6</u>	<u>\$ 10.0</u>	<u>\$ 14.8</u>

*General*—Our Real Estate Management and Development Segment consists of BMI and LandWell. BMI provides utility services, among other things, to an industrial park located in Henderson, Nevada, and is responsible for the delivery of water to the City of Henderson and various other users through a water distribution system owned by BMI. LandWell is actively engaged in efforts to develop certain real estate in Henderson, Nevada including approximately 2,100 acres zoned for residential/planned community purposes and approximately 400 acres zoned for commercial and light industrial use.

Beginning in December 2013 and through the end of 2019, LandWell has closed or entered into escrow on approximately 645 acres of the residential/planned community and approximately 65 acres zoned for commercial and light industrial use. Contracts for land sales are negotiated on an individual basis and sales terms and prices will vary based on such factors as location (including location within a planned community), expected development work, and individual buyer needs. Although land may be under contract, we do not recognize revenue until we have satisfied the criteria for revenue recognition set forth in ASC Topic 606. In some instances, we will receive cash proceeds at the time the contract closes and record deferred revenue for some or all of the cash amount received, with such deferred revenue being recognized in subsequent periods. We expect the development work to continue for 10 to 15 years on the rest of the land held for development, especially the remainder of the residential/planned community.

*Net Sales and Operating Income*— A substantial portion of the net sales from our Real Estate Management and Development segment in 2019 consisted of revenues from land sales. We recognized \$33.5 million in revenues on land sales during 2019 compared to \$32.3 million in 2018. As noted above, we recognize revenue in our residential/planned community over time using cost based input methods (previously known as percentage completion method) and substantially all of the revenue we recognized in 2018 and 2019 was under this method of revenue recognition. The contracts on these sales (both within the planned community and otherwise) include approximately 630 acres of the residential planned community and certain other acreage which closed in December 2013 and through the end of 2019. Cost of sales related to land sales revenues was \$24.5 million in 2019 compared to \$23.5 million in 2018. Land sales revenues were slightly higher in 2019 as compared to 2018 due to an increase in the amount of acreage sold in 2019 as compared to 2018 and due to higher infrastructure development spending in 2019. Land infrastructure development spending increased in 2019 as we balanced development requirements with home builder outputs during the periods along with developing new phases of our master planned community. Operating income in 2019 also includes \$8.8 million of income related to the recognition of tax increment reimbursement note receivables compared to \$3.1 million of such income in 2018, as discussed in Note 7 to our Consolidated Financial Statements.

We recognized \$32.3 million in revenues on land sales during 2018 compared to \$30.2 million in 2017. Cost of sales related to land sales revenues was \$23.5 million in 2018 compared to \$22.2 million in 2017. Land sales revenues were higher in 2018 as compared to 2017 primarily due to higher infrastructure development spending in 2018 and the relatively higher percentage completion of land sales in existing development phases during the period.

The remainder of net sales and cost of sales related to this segment primarily relates to water delivery fees and expenses. We deliver water to several customers under long-term contracts. Water delivery sales were higher in 2019 due to the timing of water delivery to our largest customer in 2018 which delayed revenue recognition until 2019.

*Outlook*— We are actively pursuing opportunities to maximize cash proceeds from the sale of our land held for development. In the near term, we are focused on developing and selling land we manage, primarily to residential builders, for the approximately 2,100 acres zoned for residential/planned community in Henderson, Nevada. We expect the development work for the first phase of the residential/planned community to continue over the next several years, including those parcels currently under contract for which the development work is expected to be completed in 2020. We do not expect to recognize significant amounts of operating income related to these sales for the parcels currently under contract because our basis in the land value is the December 2013 acquisition date fair value; however, we do expect to generate cash proceeds from these sales in excess of our acquisition costs, which proceeds are expected to be used, in part, to fund ongoing development work for the remainder of these properties. Beginning in the fourth quarter of 2017, we began sales of parcels that have a lower book value than the parcels previously sold; as a result we would expect to recognize more land sales related operating income in 2020 than in 2019.

### ***General Corporate Items, Interest Expense, Provision for Income Taxes (Benefit), Noncontrolling Interest and Related Party Transactions***

*Securities Earnings*— A significant portion of our interest and dividend income in 2017 and 2018 relates to the distributions we received from The Amalgamated Sugar Company LLC. We recognized dividend income from Amalgamated of \$25.4 million in 2017 and \$16.9 million in 2018. On August 31, 2018, we sold our interest in Amalgamated for consideration consisting of \$12.5 million in cash and the deemed payment in full of our \$250 million in loans we owed Snake River Sugar Company. We recognized a \$12.5 million securities gain on this transaction. Securities earnings were significantly lower in 2019 as compared to 2018 and 2017 primarily due to the August 2018 sale of our interest in Amalgamated. See Note 6 to our Consolidated Financial Statements.

*Insurance Recoveries*—NL has agreements with certain insurance carriers pursuant to which the carriers reimburse NL for a portion of its past lead pigment and asbestos litigation defense costs. Insurance recoveries include amounts NL received from these insurance carriers. NL received insurance recoveries of \$5.1 million in 2019 primarily related to a settlement NL reached with one of its insurance carriers in which they agreed to reimburse NL for a portion of NL's past and future litigation defense costs. In addition, Kronos recognized \$2.6 million of insurance recoveries in 2019 related to a property damage claim.

The agreements with certain of NL's insurance carriers also include reimbursement for a portion of its future litigation defense costs. We are not able to determine how much we will ultimately recover from these carriers for defense costs incurred by NL because of certain issues that arise regarding which defense costs qualify for reimbursement. Accordingly, these insurance recoveries are recognized when the receipt is probable and the amount is determinable. See Note 18 to our Consolidated Financial Statements.

*Gain on Land Sales*—In the first quarter of 2018 and the third quarter of 2019 we sold two parcels and one parcel, respectively, of land not used in our operating activities. See Note 13 to our Consolidated Financial Statements.

*Gain on Sale of Business*—In the fourth quarter of 2019, NL sold its insurance and risk management business for proceeds of \$3.25 million and recognized a pre-tax gain of \$3.0 million on the sale. See Note 13 to our Consolidated Financial Statements.

*Litigation Settlement Expense*—We recognized a pre-tax \$62.0 million and \$19.3 million litigation settlement expense in the second quarter of 2018 and 2019, respectively, related to NL's lead pigment litigation in California. See Note 18 to our Consolidated Financial Statements.

*Other Components of Net Periodic Pension Expense*—We recognized other components of net periodic pension expense of \$16.5 million in 2019, \$14.5 million in 2018, and \$17.7 million in 2017. The change in expense is primarily due to pension costs as a result of actuarial amortizations and expected returns on plan assets. See Note 11 to our Consolidated Financial Statements.

*Changes in the Market Value of Valhi Common Stock held by Subsidiaries*— Our subsidiaries Kronos and NL hold shares of our common stock. As discussed in Note 16 to our Consolidated Financial Statements, we account for our proportional interest in these shares of our common stock as treasury stock, at Kronos' and NL's historical cost basis. The remaining portion of these shares of our common stock, which are attributable to the noncontrolling interest of Kronos and NL, are reflected in our consolidated balance sheet at fair value. Prior to 2018, any unrealized gains or losses on the shares of our common stock attributable to the noncontrolling interest of Kronos and NL were recognized through other comprehensive income or loss, net of deferred income taxes, attributable to

such noncontrolling interests. Beginning on January 1, 2018 with the adoption of ASU 2016-01, *Financial Instruments – Overall (Subtopic 825-10): Recognition of Financial Assets and Financial Liabilities*, Kronos and NL recognize unrealized gains or losses in the determination of each of their respective net income or loss. Under the principles of consolidation we eliminate any gains or losses associated with our common stock to the extent of our proportional ownership interest in each subsidiary. The \$.2 and \$12.2 million loss recognized in our Consolidated Financial Statements in 2019 and 2018, respectively, represents the unrealized loss in respect of these shares during such periods attributable to the noncontrolling interest of Kronos and NL.

*Other General Corporate Items*— Corporate expenses were 12% lower at \$37.5 million in 2019 compared to \$42.4 million in 2018 primarily due to lower litigation and related costs and lower environmental remediation and related costs. Included in corporate expense are:

- litigation and related costs at NL of \$4.0 million in 2019 compared to \$6.2 million in 2018; and
- environmental remediation and related costs of \$.3 million in 2019 compared to \$3.1 million 2018.

Corporate expenses were 22% higher at \$42.4 million in 2018 compared to \$34.7 million in 2017. Corporate expenses increased due to higher administrative costs and higher litigation and related costs in 2018 somewhat offset by lower environmental remediation and related costs. Included in corporate expense are:

- litigation and related costs at NL of \$6.2 million in 2018 compared to \$3.8 million in 2017; and
- environmental remediation and related costs of \$3.1 million in 2018 compared to \$4.1 million in 2017.

Overall, we currently expect that our net general corporate expenses in 2020 will be consistent with 2019.

The level of our litigation and related expenses varies from period to period depending upon, among other things, the number of cases in which we are currently involved, the nature of such cases and the current stage of such cases (e.g. discovery, pre-trial motions, trial or appeal, if applicable). See Note 18 to our Consolidated Financial Statements. If our current expectations regarding the number of cases in which we expect to be involved during 2020, or the nature of such cases, were to change our corporate expenses could be higher than we currently estimate.

Obligations for environmental remediation and related costs are difficult to assess and estimate, and it is possible that actual costs for environmental remediation and related costs will exceed accrued amounts or that costs will be incurred in the future for sites in which we cannot currently estimate the liability. If these events occur in 2020, our corporate expense could be higher than we currently estimate. In addition, we adjust our accruals for environmental remediation and related costs as further information becomes available to us or as circumstances change. Such further information or changed circumstances could result in an increase or reduction in our accrued environmental remediation and related costs. See Note 18 to our Consolidated Financial Statements.

*Loss on Prepayment of Debt*— We recognized a loss on prepayment of debt in the third quarter of 2017 aggregating \$7.1 million, associated with the prepayment and termination of our Chemicals Segment’s term loan indebtedness. See Note 9 to our Consolidated Financial Statements.

*Interest Expense*— Interest expense decreased to \$40.8 million in 2019 from \$55.7 million in 2018 primarily due to the net effects of lower 2019 average debt levels due to the deemed redemption of the Snake River promissory notes in August 2018 and higher average interest rates on variable-rate indebtedness.

Interest expense decreased to \$55.7 million in 2018 from \$58.9 million in 2017 primarily due to the net effects of lower 2018 average debt levels somewhat offset by higher average interest rates.

We expect interest expense will be consistent in 2020 as compared to 2019 due to similar average balances of outstanding borrowings and consistent average rates. See Note 19 to our Consolidated Financial Statements.

*Provision for Income Taxes (Benefit)*—We recognized income tax expense of \$26.5 million in 2019 compared to an income tax benefit of \$30.7 million in 2018. As discussed in Note 14 to our Consolidated Financial Statements, the difference is primarily due to the third quarter 2018 recognition of a change in the deferred income tax liability related to our investment in Kronos as a result of the 2017 Tax Act and the effect of lower income from operations in 2019. We recognized an income tax benefit of \$30.7 million in 2018 compared to an income tax benefit of \$120.0 million in 2017. The difference is primarily due to the effects of our deferred income tax asset valuation allowance associated with our Chemicals Segment’s German and Belgian operations in 2017 and the impact of the 2017 Tax Act, as discussed in Note 14 to our Consolidated Financial Statements.

Our income tax expense in 2019 includes an income tax benefit of \$3.0 million related to the favorable settlement of a prior year tax matter in Germany, with \$1.5 million recognized as a current cash tax benefit and \$1.5 million recognized as a non-cash

deferred income tax benefit related to an increase to our German net operating loss carryforward. In addition, we recognized a non-cash deferred income tax expense of \$4.7 million related to the revaluation of our net deferred income tax asset in Germany resulting from a decrease in the German trade tax rate.

Our income tax benefit in 2018 includes the following:

- an aggregate non-cash deferred income tax benefit of \$112 million in 2018 related to a change in the deferred income tax liability related to our investment in Kronos, net of the revaluation of such change resulting from the reduction in the U.S. federal corporate tax rate as a result of the 2017 Tax Act;
- a \$1.8 million non-cash deferred income tax benefit related to a decrease in our effective state income tax rate; this decrease is a direct result of the sale of our interest in Amalgamated which will reduce the number of state jurisdictions in which we are required to file;
- a net \$1.4 million non-cash income tax benefit related to an APA tax settlement payment between Kronos' German and Canadian subsidiaries; and
- a \$4.0 million current cash income tax expense related to tax on GILTI.

Our income tax benefit in 2017 includes the following:

- a \$186.7 million non-cash deferred income tax benefit as a result of the reversal of our deferred income tax asset valuation allowances associated with our Chemicals Segment's German and Belgian operations mostly recognized in the second quarter;
- an \$18.7 million non-cash deferred income tax benefit as a result of the reversal of our deferred income tax asset valuation allowance related to certain U.S. deferred income tax assets of one of our Chemicals Segment's non-U.S. subsidiaries (which subsidiary is treated as a dual resident for U.S. income tax purposes);
- a \$76.2 million provisional current income tax expense as a result of the 2017 Tax Act for the one-time repatriation tax imposed on the post-1986 undistributed earnings of our Chemicals Segment's non-U.S. subsidiaries;
- a \$77.1 million non-cash deferred income tax benefit related to the revaluation of our net deferred income tax liability resulting from the reduction in the U.S. federal corporate income tax rate enacted as part of the 2017 Tax Act;
- an \$11.8 million aggregate income tax benefit related to the execution and finalization of an APA between Canada and Germany, mostly recognized in the third quarter (which includes an \$8.6 million non-cash income tax benefit as a result of a net decrease in our reserve for uncertain tax positions); and
- a \$5.3 million provisional non-cash deferred income tax expense related to a change in our conclusions regarding our permanent reinvestment assertion with respect to the post-1986 undistributed earnings of our Chemicals Segment's European subsidiaries.

Our earnings are subject to income tax in various U.S. and non-U.S. jurisdictions. Beginning in 2018 (following enactment of the 2017 Tax Act), the income tax rates applicable to the pre-tax earnings (losses) of our Chemicals Segment's non-U.S. operations are generally higher than the income tax rates applicable to our U.S. operations. Excluding the effect of any increase or decrease in our deferred income tax asset valuation allowance or changes in our reserve for uncertain tax positions, we would generally expect our overall effective tax rate to be higher than the U.S. federal statutory tax rate of 21% primarily because of our non-U.S. operations. Prior to 2018, the income tax rates applicable to the pre-tax earnings (losses) of our non-U.S. operations were generally lower than the U.S. federal statutory tax rate of 35%.

Our consolidated effective income tax rate in 2020 is expected to be higher than the U.S. federal statutory rate of 21% because the income tax rates applicable to the earnings (losses) of our non-U.S. operations will be higher than the income tax rates applicable to our U.S. operations.

See Note 14 to our Consolidated Financial Statements for more information about our 2019 income tax items, including a tabular reconciliation of our statutory tax expense (benefit) to our actual tax expense (benefit).

*Discontinued Operations*—On January 26, 2018, we completed the sale of the Waste Management Segment to JFL-WCS Partners, LLC, an entity sponsored by certain investment affiliates of J.F. Lehman & Company, for consideration consisting of the assumption of all of the Waste Management Segment's third-party indebtedness and other liabilities. We recognized a pre-tax gain of approximately \$58 million on the transaction in the first quarter of 2018 because the carrying value of the liabilities of the business assumed by the purchaser exceeded the carrying value of the assets sold in large part due to the long-lived asset impairment of \$170.6 million recognized in the second quarter of 2017 with respect to our Waste Management Segment. Such pre-tax gain is classified as part of discontinued operations. See Note 3 to our Consolidated Financial Statements for additional information.

*Noncontrolling Interest in Net Income (Loss) of Subsidiaries*—Noncontrolling interest in operations of subsidiaries decreased from 2018 to 2019 and decreased from 2017 to 2018 primarily due to changes in operating income at Kronos.

*Related Party Transactions*—We are a party to certain transactions with related parties. See Note 17 to our Consolidated Financial Statements.

## **Foreign Operations**

We have substantial operations located outside the United States, principally our Chemicals Segment's operations in Europe and Canada. The functional currency of these operations is the local currency. As a result, the reported amount of our assets and liabilities related to these foreign operations will fluctuate based upon changes in currency exchange rates. At December 31, 2019, we had substantial net assets denominated in the euro, Canadian dollar and Norwegian krone.

## **Critical accounting policies and estimates**

Our significant accounting policies are more fully described in Note 1 to our Consolidated Financial Statements. Our Consolidated Financial Statements have been prepared in accordance with accounting principles generally accepted in the United States of America, or GAAP, which requires management to make estimates, judgments and assumptions that we believe are reasonable based on our historical experience, observance of known trends in our Company and industry as a whole and information available from outside sources. Our estimates affect the reported amounts of assets and liabilities and related disclosures of contingent assets and liabilities at the date of the financial statements and the reported amounts of revenue and expense during the reporting period. Actual results may differ significantly from those initial estimates.

We believe the most critical accounting policies and estimates involving significant judgment and estimates primarily relate to goodwill, long-lived assets, revenue recognized over time using cost based inputs, defined benefit pension plans, income taxes and litigation and environmental liabilities.

*Goodwill*—Our net goodwill totaled \$379.7 million at December 31, 2019 primarily resulting from our various step acquisitions of Kronos and NL (which occurred before the implementation of the current accounting standards related to noncontrolling interest) and to a lesser extent CompX's purchase of various businesses. In accordance with the applicable accounting standards for goodwill, we do not amortize goodwill.

We perform a goodwill impairment test annually in the third quarter of each year. Goodwill is also evaluated for impairment at other times whenever an event occurs or circumstances change that would more likely than not reduce the fair value of a reporting unit below its carrying value. An entity may first assess qualitative factors to determine whether it is necessary to complete the two-step quantitative impairment test using a more-likely-than-not criteria. If an entity believes it is more-likely-than-not the fair value of a reporting unit is greater than its carrying value, including goodwill, the two-step quantitative impairment test can be bypassed. Alternatively, an entity has an unconditional option to bypass the qualitative assessment and proceed directly to performing the two-step quantitative impairment test.

When performing a qualitative assessment considerable management judgment is necessary to evaluate the qualitative impact of events and circumstances on the fair value of a reporting unit. Events and circumstances considered in our impairment evaluations, such as historical profits and stability of the markets served, are consistent with factors utilized with our internal projections and operating plan. However, future events and circumstances could result in materially different findings which could result in the recognition of a material goodwill impairment.

Evaluations of possible impairment utilizing the two-step quantitative impairment test require us to estimate, among other factors: forecasts of future operating results, revenue growth, operating margin, tax rates, capital expenditures, depreciation, working capital, weighted average cost of capital, long-term growth rates, risk premiums, terminal values, and fair values of our reporting units and assets. The goodwill impairment test is subject to uncertainties arising from such events as changes in competitive conditions, the current general economic environment, material changes in growth rate assumptions that could positively or negatively impact anticipated future operating conditions and cash flows, changes in the discount rate, and the impact of strategic decisions. If any of these factors were to materially change such change may require revaluation of our goodwill. Changes in estimates or the application of alternative assumptions could produce significantly different results.

A reporting unit can be a segment or an operating division based on the operations of the segment. For example, our Chemicals Segment produces a globally coordinated homogeneous product whereas our Component Products Segment operates as two distinct reporting units. If the fair value of the reporting unit is less than its book value, the goodwill is written down to estimated fair value.

For our Chemicals Segment, we use Level 1 inputs of publicly traded market prices to compare the book value to assess impairment. We also consider control premiums when assessing fair value. When we performed our annual goodwill impairment test in the third quarter of 2019 for our Chemicals Segment goodwill we concluded there was no impairment of such goodwill. However,



future events and circumstances could change (i.e. a significant decline in quoted market prices) and result in a materially different finding which could result in the recognition of a material impairment with respect to such goodwill.

Substantially all of the goodwill for our Component Products Segment relates to our security products reporting unit. In 2019, we used the qualitative assessment for our annual impairment test and determined it was not necessary to perform the quantitative goodwill impairment test, as we concluded it is more-likely-than-not that the fair value of the security products reporting unit exceeded its carrying amount.

*Long-lived assets*—The net book value of our property and equipment totaled \$563.0 million at December 31, 2019. We assess property and equipment for impairment only when circumstances indicate an impairment may exist. Our determination is based upon, among other things, our estimates of the amount of future net cash flows to be generated by the long-lived asset (Level 3 inputs) and our estimates of the current fair value of the asset. Significant judgment is required in estimating such cash flows. Adverse changes in such estimates of future net cash flows or estimates of fair value could result in an inability to recover the carrying value of the long-lived asset, thereby possibly requiring an impairment charge to be recognized in the future. We do not assess our property and equipment for impairment unless certain impairment indicators are present. We did not evaluate any long-lived assets for impairment during 2019 because no such impairment indicators were present.

*Revenue recognized over time using cost based inputs (formerly percentage completion revenue recognition)*—Certain real estate land sales by our Real Estate Management and Development segment (generally land sales associated with our residential/planned community) require us to complete property development and improvements after title passes to the buyer and we have received all or a substantial portion of the selling price. To date, all of the land sales associated with the residential/planned community have been recognized over time using cost based inputs of accounting in accordance with ASC 606. Under such method, revenues and profits are recognized in the same proportion of our progress towards completion of our contractual obligations, with our progress measured by costs incurred as a percentage of total costs estimated to be incurred. Such costs incurred and total estimated costs include amounts specifically identifiable with the parcels sold as well as certain development costs for the entire residential/planned community which are allocated to the parcels sold under applicable GAAP. Estimates of total costs expected to be incurred require significant management judgment, and the amount of revenue and profits that have been recognized to date are subject to revisions throughout the development period. The impact on the amount of revenue recognized resulting from any future change in the estimate of total costs estimated to be incurred would be accounted for prospectively in accordance with GAAP.

*Defined benefit pension plans*—We maintain various defined benefit pension plans in the U.S., Europe and Canada. See Note 11 to our Consolidated Financial Statements. We recognized consolidated defined benefit pension plan expense of \$29.9 million in 2017, \$26.9 million in 2018 and \$29.6 million in 2019. The amount of funding requirements for these defined benefit pension plans is generally based upon applicable regulations (such as ERISA in the U.S.) and will generally differ from pension expense for financial reporting purposes. We made contributions to all of our defined benefit pension plans of \$17.1 million in 2017, \$19.9 million in 2018 and \$19.4 million in 2019.

Under defined benefit pension plan accounting, defined benefit pension plan expense, pension assets and accrued pension costs are each recognized based on certain actuarial assumptions. These assumptions are principally the discount rate, the assumed long-term rate of return on plan assets, the fair value of plan assets and the assumed increase in future compensation levels. We recognize the funded status of our defined benefit pension plans as either an asset (for overfunded plans) or a liability (for underfunded plans) in our Consolidated Balance Sheet.

The discount rates we use for determining defined benefit pension expense and the related pension obligations are based on current interest rates earned on long-term bonds that receive one of the two highest ratings given by recognized rating agencies in the applicable country where the defined benefit pension benefits are being paid. In addition, we receive third-party advice about appropriate discount rates and these advisors may in some cases use their own market indices. We adjust these discount rates as of each December 31 valuation date to reflect then-current interest rates on such long-term bonds. We use these discount rates to determine the actuarial present value of the pension obligations as of December 31 of that year. We also use these discount rates to determine the interest component of defined benefit pension expense for the following year.

At December 31, 2019, approximately 68%, 14%, 6% and 8% of the projected benefit obligations related to our plans in Germany, Canada, Norway and the U.S., respectively. We use several different discount rate assumptions in determining our consolidated defined benefit pension plan obligation and expense. This is because we maintain defined benefit pension plans in several different countries in Europe and North America and the interest rate environment differs from country to country.

We used the following discount rates for our defined benefit pension plans:

	Discount rates used for:		
	Obligations at December 31, 2017 and expense in 2018	Obligations at December 31, 2018 and expense in 2019	Obligations at December 31, 2019 and expense in 2020
Kronos and NL Plans:			
Germany	1.8%	1.8%	1.0%
Canada	3.3%	3.5%	3.0%
Norway	2.5%	2.5%	2.3%
U.S.	3.5%	4.1%	3.1%

The assumed long-term rate of return on plan assets represents the estimated average rate of earnings expected to be earned on the funds invested or to be invested in the plans' assets provided to fund the benefit payments inherent in the projected benefit obligations. Unlike the discount rate, which is adjusted each year based on changes in current long-term interest rates, the assumed long-term rate of return on plan assets will not necessarily change based upon the actual short-term performance of the plan assets in any given year. Defined benefit pension expense each year is based upon the assumed long-term rate of return on plan assets for each plan, the actual fair value of the plan assets as of the beginning of the year and an estimate of the amount of contributions to and distributions from the plan during the year. Differences between the expected return on plan assets for a given year and the actual return are deferred and amortized over future periods based either upon the expected average remaining service life of the active plan participants (for plans for which benefits are still being earned by active employees) or the average remaining life expectancy of the inactive participants (for plans for which benefits are not still being earned by active employees).

At December 31, 2019, the fair value of plan assets for all defined benefit plans comprised \$48.4 million related to U.S. plans and \$450.0 million related to foreign plans. Substantially all of plan assets attributable to foreign plans related to plans maintained by Kronos, and approximately 70% and 30% of the plan assets attributable to U.S. plans related to plans maintained by NL and Kronos, respectively. At December 31, 2019, approximately 53%, 21%, 10% and 10% of the plan assets related to our plans in Germany, Canada, Norway and the U.S, respectively. We use several different long-term rates of return on plan asset assumptions in determining our consolidated defined benefit pension plan expense. This is because the plan assets in different countries are invested in a different mix of investments and the long-term rates of return for different investments differ from country to country.

In determining the expected long-term rate of return on plan asset assumptions, we consider the long-term asset mix (e.g. equity vs. fixed income) for the assets for each of our plans and the expected long-term rates of return for such asset components. In addition, we receive third-party advice about appropriate long-term rates of return. We regularly review our actual asset allocation for each of our U.S. and non-U.S. plans and will periodically rebalance the investments in each plan to more accurately reflect the targeted allocation when considered appropriate.

The assumed long-term rates of return on plan assets used for purposes of determining net period pension cost for 2017, 2018 and 2019 were as follows:

	2017	2018	2019
Kronos and NL plans:			
Germany	1.3%	2.0%	2.3%
Canada	4.3%	4.2%	4.0%
Norway	3.5%	4.0%	4.0%
U.S.	7.5%	7.5%	5.5%

Our long-term rate of return on plan asset assumptions in 2020 used for purposes of determining our 2020 defined benefit pension plan expense for Germany, Canada, Norway and the U.S. are 1.0%, 3.5%, 4.0% and 4.5%, respectively.

We follow ASC Topic 820, *Fair Value Measurements and Disclosures*, in determining the fair value of plan assets within our defined benefit pension plans. While we believe the valuation methods used to determine the fair value of plan assets are appropriate, the use of different methodologies or assumptions to determine the fair value of certain financial instruments could result in a different estimate of fair value at the reporting date.

To the extent that a plan's particular pension benefit formula calculates the pension benefit in whole or in part based upon future compensation levels, the projected benefit obligations and the pension expense will be based in part upon expected increases in future compensation levels. For all of our plans for which the benefit formula is so calculated, we generally base the assumed expected increase in future compensation levels upon average long-term inflation rates for the applicable country.

In addition to the actuarial assumptions discussed above, the amount of recognized defined benefit pension expense and the amount of net pension asset and net pension liability will vary based upon relative changes in currency exchange rates. See Note 11 to our Consolidated Financial Statements for additional discussion of actuarial assumptions used in determining defined benefit pension assets, liabilities and expenses.

Based on the actuarial assumptions described above and our current expectation for what actual average currency exchange rates will be during 2020, we expect our defined benefit pension expense will approximate \$33 million in 2020. In comparison, we expect to be required to contribute approximately \$19 million to such plans during 2020.

As noted above, defined benefit pension expense and the amounts recognized as accrued pension costs are based upon the actuarial assumptions discussed above. We believe all of the actuarial assumptions used are reasonable and appropriate. However, if we had lowered the assumed discount rate by 25 basis points for all plans as of December 31, 2019, our aggregate projected benefit obligations would have increased by approximately \$36 million at that date and our defined benefit pension expense would be expected to increase by approximately \$2 million during 2020. Similarly, if we lowered the assumed long-term rate of return on plan assets by 25 basis points for all of our plans, our defined benefit pension expense would be expected to increase by approximately \$1 million during 2020.

*Income taxes*—We recognize deferred taxes for future tax effects of temporary differences between financial and income tax reporting. Deferred income tax assets and liabilities for each tax-paying jurisdiction in which we operate are netted and presented as either a noncurrent deferred income tax asset or liability, as applicable. We record a valuation allowance to reduce our deferred income tax assets to the amount that is believed to be realized under the more-likely-than-not recognition criteria. While we have considered future taxable income and ongoing prudent and feasible tax planning strategies in assessing the need for a valuation allowance, it is possible that we may change our estimate of the amount of the deferred income tax assets that would more-likely-than-not be realized in the future, resulting in an adjustment to the deferred income tax asset valuation allowance that would either increase or decrease, as applicable, reported net income in the period such change in estimate was made.

For example, at December 31, 2019 our Chemicals Segment has substantial net operating loss (NOL) carryforwards in Germany (the equivalent of \$501 million for German corporate tax purposes) and in Belgium (the equivalent of \$8 million for Belgian corporate tax purposes), all of which have an indefinite carryforward period. As a result, we have or have had net deferred income tax assets with respect to these two jurisdictions, primarily related to these NOL carryforwards. As more fully described in Note 14 to our Consolidated Financial Statements we had a deferred income tax asset valuation allowance recognized with respect to such net deferred income tax assets of our Chemicals Segment's Belgian and German operations beginning June 30, 2015. At June 30, 2017 our Chemicals Segment concluded we had sufficient positive evidence under the more-likely-than-not recognition criteria to support reversal of the entire valuation allowance related to our German and Belgian operations.

*Litigation and environmental liabilities*—We are involved in numerous legal and environmental actions in part due to NL's former involvement in the manufacture of lead-based products. In accordance with applicable GAAP for accounting for contingencies, we record accruals for these liabilities when estimated future expenditures associated with such contingencies become probable, and we can reasonably estimate the amounts of such future expenditures. However, new information may become available to us, or circumstances (such as applicable laws and regulations) may change, thereby resulting in an increase or decrease in the amount we are required to accrue for such matters (and therefore a decrease or increase in our reported net income in the period of such change). At December 31, 2019 we have recorded total accrued environmental liabilities of \$99.7 million.

Obligations for environmental remediation and related costs are difficult to assess and estimate, and it is possible that actual costs for environmental remediation and related costs will exceed accrued amounts or that costs will be incurred in the future for sites in which we cannot currently estimate the liability. If these events occur in 2020, our corporate expense could be higher than we currently estimate. In addition, we adjust our accruals for environmental remediation and related costs as further information becomes available to us or as circumstances change. Such further information or changed circumstances could result in an increase or reduction in our accrued environmental remediation and related costs. See Note 18 to our Consolidated Financial Statements.

## LIQUIDITY AND CAPITAL RESOURCES

### Consolidated Cash Flows

#### *Operating Activities—*

Trends in cash flows as a result of our operating income (excluding the impact of significant asset dispositions and relative changes in assets and liabilities) are generally similar to trends in our earnings. In addition to the impact of the operating, investing and financing cash flows discussed below, changes in the amount of cash, cash equivalents and restricted cash we report from year to year can be impacted by changes in currency exchange rates, since a portion of our cash, cash equivalents and restricted cash is held by our Chemicals Segment's non-U.S. subsidiaries. For example, during 2019, relative changes in currency exchange rates resulted in a \$2.3 million decrease in the reported amount of our cash, cash equivalents and restricted cash compared to a \$14.4 million decrease in 2018 and a \$14.4 million increase in 2017.

Cash flows from operating activities increased to \$177.2 million in 2019 from \$165.5 million in 2018. This \$11.7 million increase in cash provided by operations was primarily due to the net effect of the following items:

- consolidated operating income of \$192.7 million in 2019, a decline of \$178.0 million compared to operating income of \$370.7 million in 2018;
- lower net cash paid for income taxes in 2019 of \$35.1 million due to the timing of tax payments as well as the aggregate \$11.9 million we paid in 2018 related to the Transition Tax provisions of the 2017 Tax Act;
- lower cash paid for interest in 2019 of \$16.0 million, primarily due to the redemption of the Snake River promissory notes in August 2018;
- lower net distributions to our TiO<sub>2</sub> manufacturing joint venture in 2019 of \$13.3 million, primarily due to the timing of the joint venture's working capital needs; and
- changes in receivables, inventories, payables and accrued liabilities in 2019 used \$7.1 million in net cash compared to \$89.6 million in net cash used in 2018, a decrease in the amount of cash used of \$82.5 million compared to 2018, primarily due to the relative changes in our inventories, receivables, prepaids, land held for development, payables and accruals.

Cash flows from operating activities decreased to \$165.5 million in 2018 from \$259.3 million in 2017. This \$93.8 million decrease in cash provided by operations was primarily due to the net effect of the following items:

- consolidated operating income of \$370.7 million in 2018, a decline of \$9.6 million compared to operating income of \$380.3 million in 2017;
- higher net cash paid for income taxes in 2018 of \$6.2 million due to the timing of tax payments as well as the aggregate \$11.9 million we paid in 2018 related to the Transition Tax provisions of the 2017 Tax Act;
- lower cash paid for interest in 2018 of \$5.4 million, primarily due to the redemption of the Snake River promissory notes in August 2018;
- a \$15.7 million decrease in cash provided by WCS in 2018 as a result of the sale of WCS assets in January 2018;
- higher net distributions to our TiO<sub>2</sub> manufacturing joint venture in 2018 of \$10.0 million, primarily due to the timing of the joint venture's working capital needs; and
- changes in receivables, inventories, payables and accrued liabilities in 2018 used \$89.6 million in net cash compared to \$29.9 million in net cash provided in 2017, an increase in the amount of cash used of \$119.4 million compared to 2017, primarily due to the relative changes in our inventories, receivables, prepaids, land held for development, payables and accruals.

Changes in working capital were affected by accounts receivable and inventory changes, as shown below:

- Kronos' average days sales outstanding ("DSO") was lower from December 31, 2018 to December 31, 2019, primarily due to the relative changes in the timing of collections.
- Kronos' average days sales in inventory ("DSI") decreased from December 31, 2018 to December 31, 2019 primarily due to lower inventory volumes attributable to sales volumes exceeding production volumes in 2019.
- CompX's average DSO decreased from December 31, 2018 to December 31, 2019 primarily as a result of the timing of sales and collections in the last month of 2019 as compared to 2018.
- CompX's average DSI was comparable from December 31, 2018 to December 31, 2019.

For comparative purposes, we have also provided comparable prior year numbers below.

	<u>December 31, 2017</u>	<u>December 31, 2018</u>	<u>December 31, 2019</u>
Kronos:			
Days sales outstanding	63 days	76 days	71 days
Days sales in inventory	62 days	113 days	83 days
CompX:			
Days sales outstanding	38 days	40 days	36 days
Days sales in inventory	79 days	80 days	81 days

We do not have complete access to the cash flows of our majority-owned subsidiaries, due in part to limitations contained in certain credit agreements of our subsidiaries and because we do not own 100% of these subsidiaries. A detail of our consolidated cash flows from operating activities is presented in the table below. Intercompany dividends have been eliminated.

	<u>Years ended December 31,</u>		
	<u>2017</u>	<u>2018</u>	<u>2019</u>
	(In millions)		
<i>Cash provided by (used in) operating activities:</i>			
Kronos	\$ 276.1	\$ 188.4	\$ 160.2
Valhi exclusive of subsidiaries	2.8	37.4	38.3
CompX	12.5	17.7	18.5
NL exclusive of subsidiaries	7.1	.3	10.8
Waste Control Specialists <sup>(1)</sup>	18.0	2.3	-
Tremont	(3.4)	5.8	27.0
BMI	9.1	2.9	30.2
LandWell	10.9	10.4	38.8
Eliminations	(73.8)	(99.7)	(146.6)
Total	<u>\$ 259.3</u>	<u>\$ 165.5</u>	<u>\$ 177.2</u>

(1) Discontinued operations

#### *Investing Activities—*

We disclose capital expenditures by our business segments in Note 2 to our Consolidated Financial Statements. All of our capitalized permit costs relate to our Waste Management Segment.

During 2019 we:

- had proceeds from the sale of land not used in our operations of \$4.6 million in the third quarter;
- had cash proceeds from the sale of NL's insurance and risk management business of \$2.9 million in the fourth quarter;
- received \$2.6 million from an insurance settlement related to a property damage claim in the fourth quarter; and
- had net purchases of \$.6 million of marketable securities.

During 2018 we:

- had net proceeds (excluding Amalgamated) of \$1.3 million of marketable securities;
- had proceeds from the sale of land not used in our operations of \$19.5 million in the first quarter; and
- received \$12.5 million as part of the sale of our investment in Amalgamated in the third quarter.

During 2017 we had net purchases of \$.7 million of marketable securities.

#### *Financing Activities –*

During 2019:

- we repaid a net \$1.3 million on Valhi's credit facility with Contran;
- Kronos acquired 264,992 shares of its common stock for an aggregate purchase price of \$3.1 million; and

- we repaid \$7.4 million under Tremont's promissory note payable.

During 2018, we:

- repaid a net \$6.3 million on Valhi's credit facility with Contran; and
- repaid \$3.7 million under Tremont's promissory note payable.

During 2017:

- we borrowed a net \$5.4 million on Valhi's credit facility with Contran and repaid \$1.5 million under Tremont's promissory note payable;
- Kronos issued €400 million (\$477.6 million) aggregate principal amount of 3.75% Senior Secured Notes on September 13, 2017;
- Kronos repaid the remaining balance of \$340.4 million on its term loan; and
- Kronos borrowed \$253.9 million under its North American revolving credit facility and subsequently repaid \$253.9 million.

We paid aggregate cash dividends on our common stock of \$27.2 million in 2017 and \$27.1 million in each of 2018 and 2019 (\$.02 per share each quarter). Distributions to noncontrolling interest in 2017, 2018 and 2019 are primarily comprised of: CompX dividends paid to shareholders other than NL; Kronos dividends paid to shareholders other than us and NL, and BMI and LandWell dividends paid to shareholders other than us.

### **Outstanding Debt Obligations**

At December 31, 2019, our consolidated indebtedness was comprised of:

- Valhi's \$313.0 million outstanding on its \$360 million credit facility with Contran which is due no earlier than December 31, 2021;
- €400 million aggregate outstanding on Kronos' 3.75% Senior Secured Notes (\$442.6 million carrying amount, net of unamortized debt issuance costs) due in September 2025;
- Tremont's promissory note payable (\$2.0 million outstanding) due in December 2023;
- \$17.9 million on BMI's bank loan (\$17.2 million carrying amount, net of debt issuance costs) due June 2032;
- \$15.0 million on LandWell's bank loan due April 2036;
- \$1.6 million on LandWell's note payable to the City of Henderson due in October 2020; and
- approximately \$2.9 million of other indebtedness, primarily capital lease obligations.

Certain of our credit facilities require the respective borrowers to maintain a number of covenants and restrictions which, among other things, restrict our ability to incur additional debt, incur liens, pay dividends or merge or consolidate with, or sell or transfer substantially all of our assets to, another entity, and contain other provisions and restrictive covenants customary in lending transactions of this type. Certain of our credit agreements contain provisions which could result in the acceleration of indebtedness prior to their stated maturity for reasons other than defaults for failure to comply with typical financial or payment covenants. For example, certain credit agreements allow the lender to accelerate the maturity of the indebtedness upon a change of control (as defined in the agreement) of the borrower. In addition, certain credit agreements could result in the acceleration of all or a portion of the indebtedness following a sale of assets outside the ordinary course of business. Kronos' North American and European revolvers contain a number of covenants and restrictions which, among other things, restrict its ability to incur additional debt, incur liens, pay dividends or merge or consolidate with, or sell or transfer substantially all of its assets to, another entity, and contains other provisions and restrictive covenants customary in lending transactions of this type. Kronos' European revolving credit facility also requires the maintenance of certain financial ratios, and one of such requirements is based on the ratio of net debt to the last twelve months earnings before income tax, interest, depreciation and amortization expense (EBITDA) of the borrowers. The terms of all of our debt instruments (including revolving lines of credit for which we have no outstanding borrowings at December 31, 2019) are discussed in Note 9 to our Consolidated Financial Statements. We are in compliance with all of our debt covenants at December 31, 2019. We believe that we will be able to continue to comply with the financial covenants contained in our credit facilities through their maturity; however, if future operating results differ materially from our expectations we may be unable to maintain compliance.

## Future Cash Requirements

### *Liquidity—*

Our primary source of liquidity on an ongoing basis is our cash flows from operating activities and borrowings under various lines of credit and notes. We generally use these amounts to (i) fund capital expenditures, (ii) repay short-term indebtedness incurred primarily for working capital purposes and (iii) provide for the payment of dividends (including dividends paid to us by our subsidiaries) or treasury stock purchases. From time-to-time we will incur indebtedness, generally to (i) fund short-term working capital needs, (ii) refinance existing indebtedness, (iii) make investments in marketable and other securities (including the acquisition of securities issued by our subsidiaries and affiliates) or (iv) fund major capital expenditures or the acquisition of other assets outside the ordinary course of business. Occasionally we sell assets outside the ordinary course of business, and we generally use the proceeds to (i) repay existing indebtedness (including indebtedness which may have been collateralized by the assets sold), (ii) make investments in marketable and other securities, (iii) fund major capital expenditures or the acquisition of other assets outside the ordinary course of business or (iv) pay dividends.

We routinely compare our liquidity requirements and alternative uses of capital against the estimated future cash flows we expect to receive from our subsidiaries, and the estimated sales value of those units. As a result of this process, we have in the past sought, and may in the future seek, to raise additional capital, refinance or restructure indebtedness, repurchase indebtedness in the market or otherwise, modify our dividend policies, consider the sale of our interests in our subsidiaries, affiliates, business units, marketable securities or other assets, or take a combination of these and other steps, to increase liquidity, reduce indebtedness and fund future activities. Such activities have in the past and may in the future involve related companies. From time to time we and our subsidiaries may enter into intercompany loans as a cash management tool. Such notes are structured as revolving demand notes and pay and receive interest on terms we believe are more favorable than current debt and investment market rates. The companies that borrow under these notes have sufficient borrowing capacity to repay the notes at any time upon demand. All of these notes and related interest expense and income are eliminated in our Consolidated Financial Statements.

We periodically evaluate acquisitions of interests in or combinations with companies (including our affiliates) that may or may not be engaged in businesses related to our current businesses. We intend to consider such acquisition activities in the future and, in connection with this activity, may consider issuing additional equity securities and increasing indebtedness. From time to time, we also evaluate the restructuring of ownership interests among our respective subsidiaries and related companies.

We believe we will be able to comply with the financial covenants contained in our credit facilities through their maturities; however, if future operating results differ materially from our expectations we may be unable to maintain compliance. Based upon our expectations of our operating performance, and the anticipated demands on our cash resources, we expect to have sufficient liquidity to meet our short-term (defined as the twelve-month period ending December 31, 2020) and long-term obligations (defined as the five-year period ending December 31, 2024). In this regard, see the discussion above in “*Outstanding Debt Obligations.*” If actual developments differ from our expectations, our liquidity could be adversely affected.

At December 31, 2019, we had credit available under existing facilities of \$252.6 million, which was comprised of:

- \$100.8 <sup>(1)</sup> million under Kronos’ European revolving credit facility;
- \$104.8 million under Kronos’ North American revolving credit facility; and
- \$47.0 <sup>(2)</sup> million under Valhi’s Contran credit facility.

- (1) Based on Kronos’ EBITDA over the last twelve months ending December 31, 2019, the full €90.0 million amount is available for borrowing at December 31, 2019.
- (2) Amounts available under this facility are at the sole discretion of Contran.

At December 31, 2019, we had an aggregate of \$592.1 million of restricted and unrestricted cash, cash equivalents and marketable securities attributable to continuing operations. A detail by entity is presented in the table below.

	<u>Total amount</u>	<u>Held outside U.S.</u>
	(In millions)	
Kronos	\$ 392.3	\$ 126.7
CompX	58.1	—
NL exclusive of its subsidiaries	94.6	—
BMI	14.1	—
Tremont exclusive of its subsidiaries	8.9	—
LandWell	24.0	—
Valhi exclusive of its subsidiaries	.1	—
Total cash and cash equivalents, restricted cash and marketable securities	<u>\$ 592.1</u>	<u>\$ 126.7</u>

Following the implementation of a territorial tax system under the 2017 Tax Act, repatriation of any cash and cash equivalents held by our non-U.S. subsidiaries would not be expected to result in any material income tax liability as a result of such repatriation.

*Capital Expenditures and Other Investments—*

We currently expect our aggregate capital expenditures for 2020 will be approximately \$81 million as follows:

- \$75 million by our Chemicals Segment, including approximately \$25 million in the area of environmental compliance, protection and improvement;
- \$4 million by our Component Products Segment; and
- \$2 million by our Real Estate Management and Development Segment.

In addition, LandWell expects to spend approximately \$21 million on land development costs during 2020 (which are included in the determination of cash provided by operating activities).

Capital spending for 2020 is expected to be funded primarily through cash generated from operations and borrowing under existing credit facilities. Planned capital expenditures in 2020 at Kronos and CompX will primarily be to maintain and improve the cost-effectiveness of our facilities. In addition, Kronos' capital expenditures in the area of environmental compliance, protection and improvement include expenditures which are primarily focused on increased operating efficiency but also result in improved environmental protection, such as lower emissions from our manufacturing plants.

*Repurchases of our Common Stock and Common Stock of our Subsidiaries—*

We have in the past, and may in the future, make repurchases of our common stock in market or privately-negotiated transactions. At December 31, 2019, we had approximately 4.0 million shares available for repurchase of our common stock under the authorizations described in Note 16 to our Consolidated Financial Statements.

Prior to 2017, Kronos' board of directors authorized the repurchase of up to 2.0 million shares of its common stock in open market transactions, including block purchases, or in privately-negotiated transactions at unspecified prices and over an unspecified period of time. Kronos may repurchase its common stock from time to time as market conditions permit. The stock repurchase program does not include specific price targets or timetables and may be suspended at any time. Depending on market conditions, Kronos may terminate the program prior to its completion. Kronos will use cash on hand to acquire the shares. Repurchased shares will be added to Kronos' treasury and cancelled. Kronos did not make any repurchases under the plan during 2017 and 2018. In 2019, Kronos acquired 264,992 shares of its common stock in market transactions for an aggregate purchase price of \$3.1 million and subsequently cancelled all of such shares. At December 31, 2019 approximately 1.69 million shares are available for repurchase.



Prior to 2017, CompX's board of directors authorized various repurchases of its Class A common stock in open market transactions, including block purchases, or in privately-negotiated transactions at unspecified prices and over an unspecified period of time. CompX may repurchase its common stock from time to time as market conditions permit. The stock repurchase program does not include specific price targets or timetables and may be suspended at any time. Depending on market conditions, CompX may terminate the program prior to its completion. CompX will generally use cash on hand to acquire the shares. Repurchased shares will be added to CompX's treasury and cancelled. CompX did not make any repurchases under the plan during 2017, 2018 and 2019, and at December 31, 2019 approximately 678,000 shares were available for purchase under these authorizations.

#### *Dividends—*

Because our operations are conducted primarily through subsidiaries and affiliates, our long-term ability to meet parent company level corporate obligations is largely dependent on the receipt of dividends or other distributions from our subsidiaries and affiliates. Kronos paid a regular dividend of \$.18 per share in each quarter of 2019 for which we received \$41.8 million. In February 2020 the Kronos Board of Directors approved a regular quarterly dividend of \$.18 per share. If Kronos were to pay its \$.18 per share dividend in each quarter of 2020 based on the 58.0 million shares we held of Kronos common stock at December 31, 2019, we would receive aggregate annual regular dividends from Kronos of \$41.8 million. NL has not paid a dividend since prior to 2017. In February 2020 the NL Board of Directors approved a quarterly dividend of \$.04 per share. If NL were to pay its \$.04 per share dividend in each quarter of 2020 based on the 40.4 million shares we hold of NL common stock at December 31, 2019, we would receive annual dividends from NL of \$6.5 million. BMI and LandWell do pay cash dividends from time to time, but the timing and amount of such dividends are uncertain. In this regard, we received aggregate dividends from BMI and LandWell of \$5.8 million in 2017, \$5.7 million in 2018 and \$29.1 million in 2019. In February 2020 we received aggregate dividends from BMI and LandWell of \$5.9 million. We do not know if we will receive additional distributions from BMI and LandWell during 2020. All of our ownership interest in CompX is held through our ownership in NL, as such we do not receive any dividends from CompX. Instead any dividend paid by CompX is paid to NL.

Our subsidiaries have various credit agreements with unrelated third-party lenders which contain customary limitations on the payment of dividends, typically a percentage of net income or cash flow; however, these restrictions in the past have not significantly impacted their ability to pay dividends.

#### *Investment in our Subsidiaries and Affiliates and Other Acquisitions—*

We have in the past, and may in the future, purchase the securities of our subsidiaries and affiliates or third parties in market or privately-negotiated transactions. We base our purchase decision on a variety of factors, including an analysis of the optimal use of our capital, taking into account the market value of the securities and the relative value of expected returns on alternative investments. In connection with these activities, we may consider issuing additional equity securities or increasing our indebtedness. We may also evaluate the restructuring of ownership interests of our businesses among our subsidiaries and related companies.

We generally do not guarantee any indebtedness or other obligations of our subsidiaries or affiliates. See Note 17 to our Consolidated Financial Statements. Our subsidiaries are not required to pay us dividends. If one or more of our subsidiaries were unable to maintain its current level of dividends, either due to restrictions contained in a credit agreement or to satisfy its liabilities or otherwise, our ability to service our liabilities or to pay dividends on our common stock could be adversely impacted. If this were to occur, we might consider reducing or eliminating our dividends or selling interests in subsidiaries or other assets. If we were required to liquidate assets to generate funds to satisfy our liabilities, we may be required to sell our subsidiaries' securities for less than what we believe is the long-term value of such assets.

Prior to 2017, we entered into a \$50 million revolving credit facility with a subsidiary of NL secured with approximately 35.2 million shares of the common stock of Kronos Worldwide, Inc. held by NL's subsidiary as collateral. Outstanding borrowings under the credit facility bear interest at the prime rate plus 1.875% per annum, payable quarterly, with all amounts due on December 31, 2023. The maximum principal amount which may be outstanding from time-to-time under the credit facility is limited to 50% of the amount of the most recent closing price of the Kronos stock. The credit facility contains a number of covenants and restrictions which, among other things, restrict NL's subsidiary's ability to incur additional debt, incur liens, and merge or consolidate with, or sell or transfer substantially all of NL's subsidiary's assets to, another entity, and require NL's subsidiary to maintain a minimum specified level of consolidated net worth. Upon an event of default (as defined in the credit facility), Valhi will be entitled to terminate its commitment to make further loans to NL's subsidiary, declare the outstanding loans (with interest) immediately due and payable, and exercise its rights with respect to the collateral under the loan documents. Such collateral rights include, upon certain insolvency events with respect to NL's subsidiary or NL, the right to purchase all of the Kronos common stock at a purchase price equal to the aggregate market value, less amounts owing to Valhi under the loan documents, and up to 50% of such purchase price may be paid by Valhi in the form of an unsecured promissory note bearing interest at the prime rate plus 2.75% per annum, payable quarterly, with all amounts due no later than five years from the date of purchase, with the remainder of such purchase price payable in cash at the date of purchase. We also eliminate any such intercompany borrowings in our Consolidated Financial Statements. There is \$.5 million

outstanding under this facility at December 31, 2019. We eliminate any such intercompany borrowings in our Consolidated Financial Statements.

We have an unsecured revolving demand promissory note with Kronos which, as amended, provides for borrowings from Kronos of up to \$60 million. We also eliminate any such intercompany borrowings in our Consolidated Financial Statements. We had no borrowings from Kronos prior to 2017 under this facility, which as amended is due on demand, but in any event no earlier than December 31, 2021. We had gross borrowings of \$18.2 million and gross repayments of \$4.6 million from Kronos during 2017. We had gross borrowings of \$2.6 million and gross repayments of \$16.2 million with Kronos during 2018 and there was no outstanding balance at December 31, 2018. We had gross borrowings of \$16.6 million and gross repayments of \$16.6 million with Kronos during 2019 and there was no outstanding balance at December 31, 2019. We could borrow an additional \$60.0 million under our current intercompany facility with Kronos at December 31, 2019. Kronos' obligation to loan us money under this note is at Kronos' discretion.

Prior to 2017 we entered into an unsecured revolving demand promissory note with CompX which, as amended, provides for borrowings from CompX of up to \$40 million. We eliminate these intercompany borrowings in our Consolidated Financial Statements. The facility, as amended, is due on demand, but in any event no earlier than December 31, 2021. We had gross borrowings of \$52.1 million and gross repayments of \$41.3 million with CompX in 2017. We had gross borrowings of \$52.8 million and gross repayments of \$51.0 million with CompX for a total outstanding balance of \$40.0 million at December 31, 2018. We had gross borrowings of \$34.6 million and gross repayments of \$40.8 million with CompX for a total outstanding balance of \$33.8 million at December 31, 2019. We could borrow an additional \$6.2 million under our current intercompany facility with CompX at December 31, 2019. CompX's obligation to loan us money under this note is at CompX's discretion.

### **Off-balance Sheet Financing**

We do not have any off-balance sheet financing agreements.

### **Commitments and Contingencies**

We are subject to certain commitments and contingencies, as more fully described in the Notes to our Consolidated Financial Statements and in this Management's Discussion and Analysis of Financial Condition and Results of Operations, including:

- certain income contingencies in various U.S. and non-U.S. jurisdictions;
- certain environmental remediation matters involving NL and BMI;
- certain litigation related to NL's former involvement in the manufacture of lead pigment and lead-based paint; and
- certain other litigation to which we are a party.

In addition to those legal proceedings described in Note 18 to our Consolidated Financial Statements, various legislation and administrative regulations have, from time to time, been proposed that seek to (i) impose various obligations on present and former manufacturers of lead pigment and lead-based paint (including NL) with respect to asserted health concerns associated with the use of such products and (ii) effectively overturn court decisions in which NL and other pigment manufacturers have been successful. Examples of such proposed legislation include bills which would permit civil liability for damages on the basis of market share, rather than requiring plaintiffs to prove that the defendant's product caused the alleged damage, and bills which would revive actions barred by the statute of limitations. While no legislation or regulations have been enacted to date that are expected to have a material adverse effect on our consolidated financial position, results of operations or liquidity, enactment of such legislation could have such an effect.

As more fully described in the Notes 7, 9, 18 and 19 to our Consolidated Financial Statements, we are a party to various debt, lease and other agreements which contractually and unconditionally commit us to pay certain amounts in the future. Our obligations related to the long-term supply contracts for the purchase of TiO<sub>2</sub> feedstock are more fully described in Note 18 to our Consolidated Financial Statements and above in “Business—Chemicals Segment—Kronos Worldwide, Inc.—Raw Materials.” The following table summarizes our contractual commitments as of December 31, 2019 by the type and date of payment.

Contractual commitment	Payment due date				Total
	2020	2021/ 2022	2023/ 2024	2025 and after	
	(In millions)				
Indebtedness (1):					
Principal	\$ 4.9	\$ 317.7	\$ 13.8	\$ 471.8	\$ 808.2
Interest payments	36.6	55.2	36.9	35.2	163.9
Operating leases (2)	7.1	9.9	4.0	19.4	40.4
Kronos’ long-term supply contracts to purchase TiO <sub>2</sub> feedstock (3)	490.7	406.3	—	—	897.0
Kronos’ long-term service and other supply contracts (4)	40.1	21.0	7.4	5.2	73.7
CompX’s raw material and other purchase commitments (5)	12.2	.1	—	—	12.3
Fixed asset acquisitions (2)	10.1	—	—	—	10.1
BMI and LandWell purchase commitments (6)	14.1	—	—	—	14.1
Deferred payment obligation (7)	—	—	11.1	—	11.1
Litigation settlement (8)	12.0	24.0	24.0	16.7	76.7
Estimated tax obligations (9)	14.0	11.9	26.0	18.5	70.4
Total	<u>\$ 641.8</u>	<u>\$ 846.1</u>	<u>\$ 123.2</u>	<u>\$ 566.8</u>	<u>\$2,177.9</u>

- (1) The amount shown for indebtedness involving revolving credit facilities is based upon the actual amount outstanding at December 31, 2019, and the amount shown for interest for any outstanding variable-rate indebtedness is based upon the December 31, 2019 interest rate, and assumes that such variable-rate indebtedness remains outstanding until the maturity of the facility. The timing and amount shown for principal payments on indebtedness is based on the mandatory contractual principal repayments schedule of such indebtedness, and assumes no voluntary principal prepayments. See Item 7A— “Quantitative and Qualitative Disclosures About Market Risk” and Note 9 to our Consolidated Financial Statements.
- (2) The timing and amount shown for our operating leases and fixed asset acquisitions are based upon the contractual payment amount and the contractual payment date for such commitments.
- (3) Our contracts for the purchase of TiO<sub>2</sub> feedstock contain fixed quantities of ore that we are required to purchase, or specify a range of quantities within which we are required to purchase based on our feedstock requirements. The pricing under these agreements is generally negotiated quarterly or semi-annually. The timing and amount shown for our commitments related to the supply contracts for TiO<sub>2</sub> feedstock are based upon our current estimate of the quantity of material that will be purchased in each time period shown, the payment that would be due based upon such estimated purchased quantity and an estimate of the prices for the various suppliers which is primarily based on first half 2020 pricing. The actual amount of material purchased and the actual amount that would be payable by us, may vary from such estimated amounts. The amounts shown in the table above include the feedstock ore requirements from contracts we entered into through February 2020.
- (4) The amounts shown for the long-term service and other supply contracts primarily pertain to agreements we have entered into with various providers of products or services which help to run our plant facilities (electricity, natural gas, etc.), utilizing December 31, 2019 exchange rates. See Note 18 to our Consolidated Financial Statements.
- (5) CompX’s purchase obligations consist of all open purchase orders and contractual obligations (primarily commitments to purchase raw materials) and are based on the contractual payment amount and the contractual payment date for those commitments.
- (6) BMI and LandWell’s purchase obligations consist of contractual obligations (primarily commitments for land development and improvement costs) and are based on the contractual payment amount and the contractual payment date for those commitments.
- (7) The deferred payment obligation is described in Note 10 to our Consolidated Financial Statements.
- (8) The litigation settlement is described in Note 18 to our Consolidated Financial Statements.
- (9) The amount shown for estimated tax obligations in 2020 is the consolidated amount of income taxes payable at December 31, 2019, which is assumed to be paid during 2020 and includes taxes payable, if any, to Contran as a result of our being a member of the Contran Tax Group and the amount of Transition Tax assumed to be paid in 2020. The amounts shown for estimated tax obligations in 2021 and thereafter relate to the Transition Tax which will be paid in the years indicated above. See Notes 1 and 14 to our Consolidated Financial Statements.

The table above does not include:

- Our obligations under the Louisiana Pigment Company, L.P. joint venture, as the timing and amount of such purchases are unknown and dependent on, among other things, the amount of TiO<sub>2</sub> produced by the joint venture in the future, and the joint venture's future cost of producing such TiO<sub>2</sub>. However, the table of contractual commitments does include amounts related to our share of the joint venture's ore requirements necessary for it to produce TiO<sub>2</sub> for us. See Notes 7 and 18 to our Consolidated Financial Statements and "Business—Chemicals—Kronos Worldwide, Inc."
- Amounts we might pay to fund our defined benefit pension plans, as the timing and amount of any such future fundings are unknown and dependent on, among other things, the future performance of defined benefit pension plan assets, interest rate assumptions and actual future retiree medical costs. Our defined benefit pension plans are discussed in greater detail in Note 11 to our Consolidated Financial Statements. We currently expect we will be required to contribute an aggregate of approximately \$19 million to our defined benefit pension plans during 2020.
- Any amounts that we might pay to settle any of our uncertain tax positions classified as a noncurrent liability, as the timing and amount of any such future settlements are unknown and dependent on, among other things, the timing of tax audits. See Note 14 to our Consolidated Financial Statements.

We occasionally enter into raw material supply arrangements to mitigate the short-term impact of future increases in raw material costs. While these arrangements do not necessarily commit us to a minimum volume of purchase, they generally provide for stated unit prices based upon achievement of specified volume purchase levels. This allows us to stabilize raw material purchase prices to a certain extent, provided the specified minimum monthly purchase quantities are met.

### **Recent Accounting Pronouncements**

See Note 20 to our Consolidated Financial Statements.

## ITEM 7A. QUANTITATIVE AND QUALITATIVE DISCLOSURES ABOUT MARKET RISK

*General*—We are exposed to market risk from changes in interest rates, currency exchange rates, raw materials and equity security prices.

*Interest Rates*—We are exposed to market risk from changes in interest rates, primarily related to our indebtedness.

At December 31, 2018 and 2019 our aggregate indebtedness was split between 61% of fixed-rate instruments and 39% of variable-rate borrowings. The fixed-rate debt instruments minimize earnings volatility that would result from changes in interest rates. The following table presents principal amounts and weighted average interest rates for our aggregate outstanding indebtedness at December 31, 2019.

	<u>Indebtedness* Amount</u>		<u>Year end interest rate</u>	<u>Maturity date</u>
	<u>Carrying value</u>	<u>Fair value</u>		
	(In millions)			
Fixed-rate indebtedness:				
Kronos fixed-rate Senior Notes	\$ 442.6	457.0	3.75%	2025
Tremont promissory note payable	2.0	2.0	3.00	2023
BMI bank note payable	17.2	17.9	5.34	2032
LandWell bank note payable	15.0	15.0	4.76	2036
Note payable to the City of Henderson	1.6	1.6	3.00	2020
Total fixed-rate indebtedness	<u>\$ 478.4</u>	<u>\$ 493.5</u>	3.83	
Variable-rate indebtedness:				
Valhi Contran credit facility	\$ 313.0	\$ 313.0	5.75%	2021

\* Excludes capital lease obligations.

*Currency Exchange Rates* —We are exposed to market risk arising from changes in currency exchange rates as a result of manufacturing and selling our products worldwide. Earnings are primarily affected by fluctuations in the value of the U.S. dollar relative to the euro, the Canadian dollar, the Norwegian krone and the United Kingdom pound sterling.

The majority of our sales from non-U.S. operations are denominated in currencies other than the U.S. dollar, principally the euro, other major European currencies and the Canadian dollar. A portion of our sales generated from our non-U.S. operations is denominated in the U.S. dollar (and consequently our non-U.S. operations will generally hold U.S. dollars from time to time). Certain raw materials used worldwide, primarily titanium-containing feedstocks, are purchased primarily in U.S. dollars, while labor and other production costs are purchased primarily in local currencies. Consequently, the translated U.S. dollar value of our non-U.S. sales and operating results are subject to currency exchange rate fluctuations which may favorably or unfavorably impact reported earnings. In addition to the impact of the translation of sales and expenses over time, our non-U.S. operations also generate currency transaction gains and losses which primarily relate to (i) the difference between the currency exchange rates in effect when non-local currency sales or operating costs (primarily U.S. dollar denominated) are initially accrued and when such amounts are settled with the non-local currency, (ii) changes in currency exchange rates during time periods when our non-U.S. operations are holding non-local currency (primarily U.S. dollars), and (iii) relative changes in the aggregate fair value of currency forward contracts held from time to time.

We periodically use currency forward contracts to manage a very nominal portion of currency exchange rate risk associated with trade receivables denominated in a currency other than the holder's functional currency or similar exchange rate risk associated with future sales. We have not entered into these contracts for trading or speculative purposes in the past, nor do we currently anticipate entering into such contracts for trading or speculative purposes in the future. We were not party to any currency forward contracts at December 31, 2019.

Also, we are subject to currency exchange rate risk associated with Kronos' Senior Notes, as such indebtedness is denominated in the euro. At December 31, 2019, we had the equivalent of \$447.9 million outstanding under Kronos' euro-denominated Senior Notes (exclusive of unamortized debt issuance costs.) The potential increase in the U.S. dollar equivalent of such indebtedness resulting from a hypothetical 10% adverse change in exchange rates at such date would be approximately \$45 million.

See Notes 1 and 19 to our Consolidated Financial Statements for a discussion of the assumptions we used to estimate the fair value of the financial instruments to which we are a party at December 31, 2018 and 2019.

*Raw Materials* —Our Chemicals Segment is exposed to market risk from changes in commodity prices relating to our raw materials. As discussed in Item 1 we generally enter into long-term supply agreements for certain of our raw material requirements. Many of our raw material contracts contain fixed quantities we are required to purchase, or specify a range of quantities within which

we are required to purchase. Raw material pricing under these agreements is generally negotiated quarterly or semi-annually depending upon the suppliers. For certain raw material requirements we do not have long-term supply agreements either because we have assessed the risk of the unavailability of those raw materials and/or the risk of a significant change in the cost of those raw materials to be low, or because long-term supply agreements for those raw materials are generally not available.

Our Component Products Segment will occasionally enter into short term commodity-related raw material supply arrangements to mitigate the impact of future increases in commodity-related raw material costs. We do not have long-term supply agreements for our raw material requirements because either we believe the risk of unavailability of those raw materials is low and we believe the downside risk of price volatility to be too great or because long-term supply agreements for those materials are generally not available. We do not engage in commodity raw material hedging programs.

*Marketable Equity and Debt Security Prices* —We are exposed to market risk due to changes in prices of the marketable securities we own. The fair value of such debt and equity securities (determined using Level 1, Level 2 and Level 3 inputs) at December 31, 2018 and 2019 was \$7.3 million and \$8.3 million, respectively. The potential change in the aggregate fair value of these investments, assuming a hypothetical 10% change in prices, would be approximately \$.7 and \$.8 million at December 31, 2018 and 2019, respectively.

*Other* —We believe there may be a certain amount of incompleteness in the sensitivity analyses presented above. For example, the hypothetical effect of changes in interest rates discussed above ignores the potential effect on other variables that affect our results of operations and cash flows, such as demand for our products, sales volumes and selling prices and operating expenses. Contrary to the above assumptions, changes in interest rates rarely result in simultaneous comparable shifts along the yield curve. Accordingly, the amounts we present above are not necessarily an accurate reflection of the potential losses we would incur assuming the hypothetical changes in market prices were actually to occur.

The above discussion and estimated sensitivity analysis amounts include forward-looking statements of market risk which assume hypothetical changes in market prices. Actual future market conditions will likely differ materially from such assumptions. Accordingly, such forward-looking statements should not be considered to be projections by us of future events, gains or losses.

## **ITEM 8. FINANCIAL STATEMENTS AND SUPPLEMENTARY DATA**

The information called for by this Item is contained in a separate section of this Annual Report. See “Index of Financial Statements” (page F-1).

## **ITEM 9. CHANGES IN AND DISAGREEMENTS WITH ACCOUNTANTS ON ACCOUNTING AND FINANCIAL DISCLOSURE**

None.

## **ITEM 9A. CONTROLS AND PROCEDURES**

*Evaluation of Disclosure Controls and Procedures*—

We maintain disclosure controls and procedures which, as defined in Exchange Act Rule 13a-15(e), means controls and other procedures that are designed to ensure that information required to be disclosed in the reports we file or submit to the SEC under the Securities Exchange Act of 1934, as amended (the “Act”), is recorded, processed, summarized and reported, within the time periods specified in the SEC’s rules and forms. Disclosure controls and procedures include, without limitation, controls and procedures designed to ensure that information we are required to disclose in the reports we file or submit to the SEC under the Act is accumulated and communicated to our management, including our principal executive officer and our principal financial officer, or persons performing similar functions, as appropriate to allow timely decisions to be made regarding required disclosure. Each of Robert D. Graham, our Vice Chairman of the Board, President and Chief Executive Officer, and James W. Brown, our Senior Vice President and Chief Financial Officer, have evaluated the design and effectiveness of our disclosure controls and procedures as of December 31, 2019. Based upon their evaluation, these executive officers have concluded that our disclosure controls and procedures were effective as of the date of such evaluation.

*Management's Report on Internal Control over Financial Reporting—*

Our management is responsible for establishing and maintaining adequate internal control over financial reporting which, as defined by Exchange Act Rule 13a-15(f) means a process designed by, or under the supervision of, our principal executive and principal financial officers, or persons performing similar functions, and effected by the board of directors, management and other personnel, to provide reasonable assurance regarding the reliability of financial reporting and the preparation of financial statements for external purposes in accordance with generally accepted accounting principles, and includes those policies and procedures that:

- Pertain to the maintenance of records that in reasonable detail accurately and fairly reflect the transactions and dispositions of our assets,
- Provide reasonable assurance that transactions are recorded as necessary to permit preparation of financial statements in accordance with GAAP, and that receipts and expenditures are being made only in accordance with authorizations of management and directors, and
- Provide reasonable assurance regarding prevention or timely detection of an unauthorized acquisition, use or disposition of assets that could have a material effect on our Consolidated Financial Statements.

Our evaluation of the effectiveness of internal control over financial reporting is based upon the criteria established in *Internal Control – Integrated Framework* issued by the Committee of Sponsoring Organizations of the Treadway Commission in 2013 (commonly referred to as the “2013 COSO” framework). Based on our evaluation under that framework, we have concluded that our internal control over financial reporting was effective as of December 31, 2019.

PricewaterhouseCoopers LLP, the independent registered public accounting firm that has audited our consolidated financial statements included in this Annual Report, has audited the effectiveness of our internal control over financial reporting as of December 31, 2019, as stated in their report, which is included in this Annual Report on Form 10-K.

*Other—*

As permitted by the SEC, our assessment of internal control over financial reporting excludes (i) internal control over financial reporting of equity method investees and (ii) internal control over the preparation of any financial statement schedules which would be required by Article 12 of Regulation S-X. However, our assessment of internal control over financial reporting with respect to equity method investees did include controls over the recording of amounts related to our investments that are recorded in the consolidated financial statements, including controls over the selection of accounting methods for our investments, the recognition of equity method earnings and losses and the determination, valuation and recording of our investment account balances.

*Changes in Internal Control over Financial Reporting—*

There has been no change to our internal control over financial reporting during the quarter ended December 31, 2019 that has materially affected, or is reasonably likely to materially affect, our internal control over financial reporting.

*Certifications—*

Our chief executive officer is required to annually file a certification with the New York Stock Exchange, or NYSE, certifying our compliance with the corporate governance listing standards of the NYSE. During 2019, our chief executive officer filed such annual certification with the NYSE. The 2019 certification was unqualified.

Our chief executive officer and chief financial officer are also required to, among other things, file quarterly certifications with the SEC regarding the quality of our public disclosures, as required by Section 302 of the Sarbanes-Oxley Act of 2002. The certifications for the quarter ended December 31, 2019 have been filed as Exhibits 31.1 and 31.2 to this Annual Report on Form 10-K.

**ITEM 9B. OTHER INFORMATION**

Not applicable.

## PART III

### ITEM 10. DIRECTORS, EXECUTIVE OFFICERS AND CORPORATE GOVERNANCE

The information required by this Item is incorporated by reference to our 2020 definitive proxy statement we will file with the SEC pursuant to Regulation 14A within 120 days after the end of the fiscal year covered by this report (the “Valhi Proxy Statement”).

### ITEM 11. EXECUTIVE COMPENSATION

The information required by this Item is incorporated by reference to our 2020 proxy statement.

### ITEM 12. SECURITY OWNERSHIP OF CERTAIN BENEFICIAL OWNERS AND MANAGEMENT AND RELATED STOCKHOLDER MATTERS

The information required by this Item is incorporated by reference to our 2020 proxy statement.

### ITEM 13. CERTAIN RELATIONSHIPS AND RELATED TRANSACTIONS AND DIRECTORS INDEPENDENCE

The information required by this Item is incorporated by reference to our 2020 proxy statement. See also Note 17 to our Consolidated Financial Statements.

### ITEM 14. PRINCIPAL ACCOUNTING FEES AND SERVICES

The information required by this Item is incorporated by reference to our 2020 proxy statement.

## PART IV

### ITEM 15. EXHIBITS

#### (a) and (c) Financial Statements

##### *The Registrant*

Our Consolidated Financial Statements listed on the accompanying Index of Financial Statements (see page F-1) are filed as part of this Annual Report.

##### *50%-or-less owned persons*

We are not required to provide any consolidated financial statements pursuant to Rule 3-09 of Regulation S-X.

#### (b) Exhibits

Included as exhibits are the items listed in the Exhibit Index. We have retained a signed original of any of these exhibits that contain signatures, and we will provide such exhibit to the Commission or its staff upon request. We will furnish a copy of any of the exhibits listed below upon request and payment of \$4.00 per exhibit to cover our costs of furnishing the exhibits. Such requests should be directed to the attention of our Corporate Secretary at our corporate offices located at 5430 LBJ Freeway, Suite 1700, Dallas, Texas 75240. Pursuant to Item 601(b)(4)(iii) of Regulation S-K, we will furnish to the Commission upon request any instrument defining the rights of holders of long-term debt issues and other agreements related to indebtedness which do not exceed 10% of our consolidated total assets as of December 31, 2019.



Item No.	Exhibit Index
2.1	Purchase Agreement by and between JFL-WCS Partners, LLC, as Purchaser, and Andrews County Holdings, Inc., as Seller, dated as of December 19, 2017 – incorporated by reference to Exhibit 2.1 to our Current Report on Form 8-K (File No. 1-5467) dated January 26, 2018 and filed on January 26, 2018.
2.2	Amendment to Purchase Agreement by and between JFL-WCS Partners, LLC, as Purchaser, and Andrews County Holdings, Inc., as Seller, dated as of January 19, 2018 – incorporated by reference to Exhibit 2.2 to our Current Report on Form 8-K (File No. 1-5467) dated January 26, 2018 and filed on January 26, 2018.
3.1	Third Amended and Restated Certificate of Incorporation of Valhi, Inc. – incorporated by reference to Exhibit 3.1 to our Current Report on Form 8-K (File no. 1-5467) dated May 27, 2016 and filed on May 31, 2016.
3.2	Amended and Restated By-Laws of Valhi, Inc. —incorporated by reference to Exhibit 3.1 of our Current Report on Form 8-K (File No. 1-5467) dated November 6, 2007.
4.1	Description of Capital Stock —incorporated by reference to Exhibit 99.2 of our Current Report on Form 8-K dated March 11, 2019 (file No. 1-5467) and filed on March 11, 2019.
10.1	Intercorporate Services Agreement between Valhi, Inc. and Contran Corporation effective as of January 1, 2004—incorporated by reference to Exhibit 10.1 to our Quarterly Report on Form 10-Q for the quarter ended March 31, 2004.
10.2	Intercorporate Services Agreement between Contran Corporation and NL Industries, Inc. effective as of January 1, 2004—incorporated by reference to Exhibit 10.1 to NL’s Quarterly Report on Form 10-Q (File No. 1-640) for the quarter ended March 31, 2004.
10.3	Intercorporate Services Agreement between Contran Corporation and CompX International Inc. effective January 1, 2004—incorporated by reference to Exhibit 10.2 to CompX’s Annual Report on Form 10-K (File No. 1-13905) for the year ended December 31, 2003.
10.4	Intercorporate Services Agreement between Contran Corporation and Kronos Worldwide, Inc. effective January 1, 2004—incorporated by reference to Exhibit No. 10.1 to Kronos’ Quarterly Report on Form 10-Q (File No. 1-31763) for the quarter ended March 31, 2004.
10.5**	Tax Agreement between Valhi, Inc. and Contran Corporation dated January 1, 2020.
10.6*	Valhi, Inc. 2012 Director Stock Plan—incorporated by reference to Exhibit 4.5 of the Registration statement on Form S-8 of the Registrant (File No. 333-48391). Filed on May 31, 2012.
10.7*	Kronos Worldwide, Inc. 2012 Director Stock Plan—incorporated by reference to Exhibit 4.4 of the Registration statement on Form S-8 of the Registrant (File No. 333-113425). Filed on May 31, 2012.
10.8*	CompX International Inc. 2012 Director Stock Plan—incorporated by reference to Exhibit 4.4 of the Registration statement on Form S-8 of the Registrant (File No. 333-47539). Filed on May 31, 2012.
10.9*	NL Industries, Inc. 2012 Director Stock Plan—incorporated by reference to Exhibit 4.4 of the Registration statement on Form S-8 of the Registrant (File No. 001-00640). Filed on May 31, 2012.
10.10	Second Amended and Restated Agreement Regarding Shared Insurance among CompX International Inc., Contran Corporation, Kronos Worldwide, Inc., NL Industries, Inc. and Valhi, Inc. dated January 25, 2019 —incorporated by reference to Exhibit 10.10 to our Annual Report on Form 10-K for the year ended December 31, 2018 (file No. 1-5467) filed on March 11, 2019.
10.11	Master Purchase and Termination Agreement dated May 30, 2018 by and between the registrant, ASC Holdings, Inc., Snake River Sugar Company, The Amalgamated Sugar Company LLC and the Amalgamated Collateral Trust - incorporated by reference to Exhibit 10.1 to our Current Report on Form 8-K (File No. 1-5467) dated May 30, 2018 and filed by the registrant on June 4, 2018.
10.12	Closing Agreement dated August 31, 2018 by and between the registrant, ASC Holdings, Inc., Snake River Sugar Company, The Amalgamated Sugar Company LLC, the Amalgamated Collateral Trust and the other parties named therein - incorporated by reference to Exhibit 10.1 to our Current Report on Form 8-K (File No. 1-5467) dated August 31, 2018 and filed by the registrant on September 5, 2018.

Item No.	Exhibit Index
10.13	Formation Agreement dated as of October 18, 1993 among Tioxide Americas Inc., Kronos Louisiana, Inc. and Louisiana Pigment Company, L.P.—incorporated by reference to Exhibit 10.2 of NL’s Quarterly Report on Form 10-Q (File No. 1-640) for the quarter ended September 30, 1993. (P)
10.14	Joint Venture Agreement dated as of October 18, 1993 between Tioxide Americas Inc. and Kronos Louisiana, Inc.—incorporated by reference to Exhibit 10.3 of NL’s Quarterly Report on Form 10-Q (File No. 1-640) for the quarter ended September 30, 1993. (P)
10.15	Kronos Offtake Agreement dated as of October 18, 1993 by and between Kronos Louisiana, Inc. and Louisiana Pigment Company, L.P.—incorporated by reference to Exhibit 10.4 of NL’s Quarterly Report on Form 10-Q (File No. 1-640) for the quarter ended September 30, 1993. (P)
10.16	Amendment No. 1 to Kronos Offtake Agreement dated as of December 20, 1995 between Kronos Louisiana, Inc. and Louisiana Pigment Company, L.P.—incorporated by reference to Exhibit 10.22 of NL’s Annual Report on Form 10-K (File No. 1-640) for the year ended December 31 1995. (P)
10.17	Allocation Agreement dated as of October 18, 1993 between Tioxide Americas Inc., ICI American Holdings, Inc., Kronos Worldwide, Inc. (f/k/a Kronos, Inc.) and Kronos Louisiana, Inc.—incorporated by reference to Exhibit 10.10 to NL’s Quarterly Report on Form 10-Q (File No. 1-640) for the quarter ended September 30, 1993. (P)
10.18	Lease Contract dated June 21, 1952, between Farbenfabriken Bayer Aktiengesellschaft and Titangesellschaft mit beschränkter Haftung (German language version and English translation thereof)—incorporated by reference to Exhibit 10.14 of NL’s Annual Report on Form 10-K (File No. 1-640) for the year ended December 31, 1985. (P)
10.19	Restated and Amended Agreement by and between Richards Bay Titanium (Proprietary) Limited (acting through its sales agent Rio Tinto Iron & Titanium Limited) and Kronos (US), Inc. effective January 1, 2016 – incorporated by reference to Exhibit 10.26 to the Annual Report on Form 10-K of Kronos Worldwide, Inc. (File No. 001-31763) for the year ended December 31, 2015.
10.20	Indenture, dated as of September 13, 2017, among Kronos International, Inc. the guarantors named therein, and Deutsche Bank Trust Company Americas, as trustee, collateral agent, paying agent, transfer agent and registrar – incorporated by reference to Exhibit 4.1 to the Current Report on Form 8-K (File No. 001-31763) dated September 13, 2017 and filed by Kronos Worldwide, Inc. on September 13, 2017.
10.21	Pledge Agreement, dated as of September 13, 2017, among Kronos International, Inc. the guarantors named therein and Deutsche Bank Trust Company Americas, as collateral agent – incorporate by reference to Exhibit 4.2 to the Current Report on Form 8-K (File No. 001-31763) dated September 13, 2017 and filed by Kronos Worldwide, Inc. on September 13, 2017.
10.22**	Amended and Restated Unsecured Revolving Demand Promissory Note dated December 31, 2019 in the principal amount of \$360.0 million executed by Valhi, Inc. and payable to the order of Contran Corporation.
10.23	Collateral Agreement dated March 12, 2013 between Valhi, Inc. and Contran Corporation —incorporated by reference to Exhibit 10.23 to our Annual Report on Form 10-K for the year ended December 31, 2018 (file No. 1-5467) filed on March 11, 2019.
21.1**	Subsidiaries of Valhi, Inc.
23.1**	Consent of PricewaterhouseCoopers LLP with respect to Valhi’s Consolidated Financial Statements
31.1**	Certification
31.2**	Certification
32.1**	Certification
101.INS **	XBRL Instance Document
101.SCH **	XBRL Taxonomy Extension Schema
101.CAL **	XBRL Taxonomy Extension Calculation Linkbase
101.DEF **	XBRL Taxonomy Extension Definition Linkbase
101.LAB **	XBRL Taxonomy Extension Label Linkbase

101.PRE \*\* XBRL Taxonomy Extension Presentation Linkbase

\* Management contract, compensatory plan or agreement.

\*\* Filed herewith.

(P) Paper exhibits.

## SIGNATURES

Pursuant to the requirements of Section 13 or 15(d) of the Securities Exchange Act of 1934, the Registrant has duly caused this report to be signed on its behalf by the undersigned, thereunto duly authorized.

VALHI, INC.  
(Registrant)

By: /s/ Robert D. Graham  
Robert D. Graham, March 12, 2020  
(Vice Chairman of the Board, President and Chief Executive Officer)

Pursuant to the requirements of the Securities Exchange Act of 1934, this report has been signed below by the following persons on behalf of the Registrant and in the capacities and on the dates indicated:

/s/ Loretta J. Feehan  
Loretta J. Feehan, March 12, 2020  
(Chair of the Board (non-executive))

/s/ Robert D. Graham  
Robert D. Graham, March 12, 2020  
(Vice Chairman of the Board, President and Chief Executive Officer)

/s/ Thomas E. Barry  
Thomas E. Barry, March 12, 2020  
(Director)

/s/ James W. Brown  
James W. Brown, March 12, 2020  
(Senior Vice President and Chief Financial Officer)

/s/ Terri L. Herrington  
Terri L. Herrington, March 12, 2020  
(Director)

/s/ Amy Allbach Samford  
Amy Allbach Samford, March 12, 2020  
(Vice President and Controller)

/s/ W. Hayden McIlroy  
W. Hayden McIlroy, March 12, 2020  
(Director)

/s/ Mary A. Tidlund  
Mary A. Tidlund, March 12, 2020  
(Director)

**Annual Report on Form 10-K**  
**Items 8, 15(a) and 15(c)**  
**Index of Financial Statements**

	<b>Page</b>
<b>Financial Statements</b>	
Report of Independent Registered Public Accounting Firm .....	F-2
Consolidated Balance Sheets—December 31, 2018 and 2019 .....	F-4
Consolidated Statements of Income—Years ended December 31, 2017, 2018 and 2019.....	F-6
Consolidated Statements of Comprehensive Income—Years ended December 31, 2017, 2018 and 2019 .....	F-7
Consolidated Statements of Stockholders’ Equity—Years ended December 31, 2017, 2018 and 2019.....	F-8
Consolidated Statements of Cash Flows—Years ended December 31, 2017, 2018 and 2019.....	F-9
Notes to Consolidated Financial Statements.....	F-11

We have omitted all financial statement schedules because they are not applicable or the required amounts are either not material or are presented in the Notes to the Consolidated Financial Statements.



## **Report of Independent Registered Public Accounting Firm**

To the Board of Directors and Stockholders of Valhi, Inc.

### ***Opinions on the Financial Statements and Internal Control over Financial Reporting***

We have audited the accompanying consolidated balance sheets of Valhi, Inc. and its subsidiaries (the “Company”) as of December 31, 2019 and 2018, and the related consolidated statements of income, of comprehensive income, of stockholders’ equity and of cash flows for each of the three years in the period ended December 31, 2019, including the related notes (collectively referred to as the “consolidated financial statements”). We also have audited the Company’s internal control over financial reporting as of December 31, 2019, based on criteria established in *Internal Control - Integrated Framework* (2013) issued by the Committee of Sponsoring Organizations of the Treadway Commission (COSO).

In our opinion, the consolidated financial statements referred to above present fairly, in all material respects, the financial position of the Company as of December 31, 2019 and 2018, and the results of its operations and its cash flows for each of the three years in the period ended December 31, 2019 in conformity with accounting principles generally accepted in the United States of America. Also in our opinion, the Company maintained, in all material respects, effective internal control over financial reporting as of December 31, 2019, based on criteria established in *Internal Control - Integrated Framework* (2013) issued by the COSO.

### ***Basis for Opinions***

The Company’s management is responsible for these consolidated financial statements, for maintaining effective internal control over financial reporting, and for its assessment of the effectiveness of internal control over financial reporting, included in Management’s Report on Internal Control over Financial Reporting appearing under Item 9A. Our responsibility is to express opinions on the Company’s consolidated financial statements and on the Company’s internal control over financial reporting based on our audits. We are a public accounting firm registered with the Public Company Accounting Oversight Board (United States) (PCAOB) and are required to be independent with respect to the Company in accordance with the U.S. federal securities laws and the applicable rules and regulations of the Securities and Exchange Commission and the PCAOB.

We conducted our audits in accordance with the standards of the PCAOB. Those standards require that we plan and perform the audits to obtain reasonable assurance about whether the consolidated financial statements are free of material misstatement, whether due to error or fraud, and whether effective internal control over financial reporting was maintained in all material respects.

Our audits of the consolidated financial statements included performing procedures to assess the risks of material misstatement of the consolidated financial statements, whether due to error or fraud, and performing procedures that respond to those risks. Such procedures included examining, on a test basis, evidence regarding the amounts and disclosures in the consolidated financial statements. Our audits also included evaluating the accounting principles used and significant estimates made by management, as well as evaluating the overall presentation of the consolidated financial statements. Our audit of internal control over financial reporting included obtaining an understanding of internal control over financial reporting, assessing the risk that a material weakness exists, and testing and evaluating the design and operating effectiveness of internal control based on the assessed risk. Our audits also included performing such other procedures as we considered necessary in the circumstances. We believe that our audits provide a reasonable basis for our opinions.



***Definition and Limitations of Internal Control over Financial Reporting***

A company's internal control over financial reporting is a process designed to provide reasonable assurance regarding the reliability of financial reporting and the preparation of financial statements for external purposes in accordance with generally accepted accounting principles. A company's internal control over financial reporting includes those policies and procedures that (i) pertain to the maintenance of records that, in reasonable detail, accurately and fairly reflect the transactions and dispositions of the assets of the company; (ii) provide reasonable assurance that transactions are recorded as necessary to permit preparation of financial statements in accordance with generally accepted accounting principles, and that receipts and expenditures of the company are being made only in accordance with authorizations of management and directors of the company; and (iii) provide reasonable assurance regarding prevention or timely detection of unauthorized acquisition, use, or disposition of the company's assets that could have a material effect on the financial statements.

Because of its inherent limitations, internal control over financial reporting may not prevent or detect misstatements. Also, projections of any evaluation of effectiveness to future periods are subject to the risk that controls may become inadequate because of changes in conditions, or that the degree of compliance with the policies or procedures may deteriorate.

*PricewaterhouseCoopers LLP*

Dallas, Texas  
March 12, 2020

We have served as the Company's auditor since 1987.

**VALHI, INC. AND SUBSIDIARIES**  
**CONSOLIDATED BALANCE SHEETS**  
(In millions)

ASSETS	December 31,	
	2018	2019
Current assets:		
Cash and cash equivalents	\$ 499.8	\$ 523.8
Restricted cash equivalents	15.0	27.0
Marketable securities	2.5	2.1
Accounts and other receivables, net	318.4	314.0
Accrued insurance recovery related to litigation settlement	15.0	-
Refundable income taxes	5.7	7.9
Receivables from affiliates	13.5	7.3
Inventories, net	515.8	522.1
Other current assets	23.1	21.2
Total current assets	1,408.8	1,425.4
Other assets:		
Marketable securities	4.8	6.2
Investment in TiO2 manufacturing joint venture	81.3	90.2
Goodwill	379.7	379.7
Deferred income taxes	101.0	106.0
Pension asset	2.7	7.4
Other assets	167.8	216.5
Total other assets	737.3	806.0
Property and equipment:		
Land	46.6	46.2
Buildings	250.5	248.0
Equipment	1,155.2	1,166.0
Mining properties	28.6	26.2
Construction in progress	44.2	62.7
	1,525.1	1,549.1
Less accumulated depreciation and amortization	961.6	986.1
Net property and equipment	563.5	563.0
Total assets	\$ 2,709.6	\$ 2,794.4



**VALHI, INC. AND SUBSIDIARIES**  
**CONSOLIDATED BALANCE SHEETS (CONTINUED)**  
(In millions, except share data)

<b>LIABILITIES AND STOCKHOLDERS' EQUITY</b>	<b>December 31,</b>	
	<b>2018</b>	<b>2019</b>
Current liabilities:		
Current maturities of long-term debt	\$ 2.9	\$ 4.9
Accounts payable	111.5	144.7
Accrued liabilities	140.8	130.5
Accrued litigation settlement	60.0	11.8
Payables to affiliates	26.7	20.4
Income taxes	9.1	10.2
Total current liabilities	351.0	322.5
Noncurrent liabilities:		
Long-term debt	797.5	789.4
Deferred income taxes	41.2	38.1
Payables to affiliates	56.3	56.3
Long-term litigation settlement	17.0	60.1
Accrued pension costs	273.3	315.6
Accrued environmental remediation and related costs	96.9	95.2
Other liabilities	87.4	137.1
Total noncurrent liabilities	1,369.6	1,491.8
Equity:		
Preferred stock, \$.01 par value; 5,000 shares authorized; 5,000 shares issued	667.3	667.3
Common stock, \$.01 par value; 500.0 million shares authorized; 355.3 million and 355.4 million shares issued and outstanding	3.6	3.6
Additional paid-in capital	-	-
Retained earnings	220.3	239.4
Accumulated other comprehensive loss	(206.2)	(220.7)
Treasury stock, at cost - 13.2 million shares	(49.6)	(49.6)
Total Valhi stockholders' equity	635.4	640.0
Noncontrolling interest in subsidiaries	353.6	340.1
Total equity	989.0	980.1
Total liabilities and equity	\$ 2,709.6	\$ 2,794.4

Commitments and contingencies (Notes 9, 14, 17 and 18)

See accompanying Notes to Consolidated Financial Statements.

**VALHI, INC. AND SUBSIDIARIES**  
**CONSOLIDATED STATEMENTS OF INCOME**  
(In millions, except per share data)

	Years ended December 31,		
	2017	2018	2019
Revenues and other income:			
Net sales	\$ 1,879.4	\$ 1,820.1	\$ 1,897.5
Other income, net	25.2	69.2	40.9
Total revenues and other income	1,904.6	1,889.3	1,938.4
Cost and expenses:			
Cost of sales	1,266.5	1,210.9	1,462.9
Selling, general and administrative	262.6	310.0	294.2
Litigation settlement expense, net	-	62.0	19.3
Loss on prepayment of debt	7.1	-	-
Other components of net periodic pension expense	17.7	14.5	16.5
Interest	58.9	55.7	40.8
Total costs and expenses	1,612.8	1,653.1	1,833.7
Income from continuing operations before income taxes	291.8	236.2	104.7
Income tax expense (benefit)	(120.0)	(30.7)	26.5
Net income from continuing operations	411.8	266.9	78.2
Income (loss) from discontinued operations, net of tax	(109.2)	34.1	-
Net income	302.6	301.0	78.2
Noncontrolling interest in net income of subsidiaries	95.1	38.8	29.0
Net income attributable to Valhi stockholders	\$ 207.5	\$ 262.2	\$ 49.2
Amounts attributable to Valhi stockholders:			
Income from continuing operations	\$ 316.7	\$ 228.1	\$ 49.2
Income (loss) from discontinued operations	(109.2)	34.1	-
Net income attributable to Valhi stockholders	\$ 207.5	\$ 262.2	\$ 49.2
Basic and diluted net income (loss) per share:			
Income from continuing operations	\$ .93	\$ .67	\$ .14
Income (loss) from discontinued operations	(.32)	.10	-
Net income per basic and diluted share	\$ .61	\$ .77	\$ .14
Basic and diluted weighted average shares outstanding	342.0	342.0	342.1

See accompanying Notes to Consolidated Financial Statements.

**VALHI, INC. AND SUBSIDIARIES**

**CONSOLIDATED STATEMENTS OF COMPREHENSIVE INCOME**

(In millions)

	Years ended December 31,		
	2017	2018	2019
Net income	\$ 302.6	\$ 301.0	\$ 78.2
Other comprehensive income (loss), net of tax:			
Currency translation	47.9	(29.4)	(1.8)
Interest rate swap	1.5	-	-
Marketable securities	5.0	-	-
Defined benefit pension plans	11.0	(6.8)	(17.3)
Other	(0.8)	(0.9)	(0.8)
Total other comprehensive income (loss), net	64.6	(37.1)	(19.9)
Comprehensive income	367.2	263.9	58.3
Comprehensive income attributable to noncontrolling interest	116.8	29.0	23.5
Comprehensive income attributable to Valhi stockholders	\$ 250.4	\$ 234.9	\$ 34.8

See accompanying Notes to Consolidated Financial Statements.

**VALHI, INC. AND SUBSIDIARIES**  
**CONSOLIDATED STATEMENTS OF STOCKHOLDERS' EQUITY**  
**Years ended December 31, 2017, 2018 and 2019**  
**(In millions)**

	<b>Valhi Stockholders' Equity</b>							
	<b>Preferred stock</b>	<b>Common stock</b>	<b>Additional paid-in capital</b>	<b>Retained earnings (deficit)</b>	<b>Accumulated other comprehensive income (loss)</b>	<b>Treasury stock</b>	<b>Non- controlling interest</b>	<b>Total equity</b>
Balance at December 31, 2016	\$ 667.3	\$ 3.6	\$ -	\$ (198.5)	\$ (221.9)	\$ (49.6)	\$ 243.5	\$ 444.4
Net income	-	-	-	207.5	-	-	95.1	302.6
Cash dividends - \$.08 per share	-	-	(.3)	(26.9)	-	-	-	(27.2)
Dividends paid to noncontrolling interest	-	-	-	-	-	-	(18.1)	(18.1)
Other comprehensive income, net	-	-	-	-	42.9	-	21.7	64.6
Equity transactions with noncontrolling interest, net	-	-	.3	-	-	-	.1	.4
Balance at December 31, 2017	667.3	3.6	-	(17.9)	(179.0)	(49.6)	342.3	766.7
Change in accounting principle - ASU 2014-09	-	-	-	2.7	-	-	2.3	5.0
Balance at January 1, 2018, as adjusted	667.3	3.6	-	(15.2)	(179.0)	(49.6)	344.6	771.7
Net income	-	-	-	262.2	-	-	38.8	301.0
Cash dividends - \$.08 per share	-	-	(.4)	(26.7)	-	-	-	(27.1)
Dividends paid to noncontrolling interest	-	-	-	-	-	-	(20.1)	(20.1)
Other comprehensive loss, net	-	-	-	-	(27.3)	-	(9.8)	(37.1)
Equity transactions with noncontrolling interest, net	-	-	.4	-	.1	-	.1	.6
Balance at December 31, 2018	667.3	3.6	-	220.3	(206.2)	(49.6)	353.6	989.0
Net income	-	-	-	49.2	-	-	29.0	78.2
Cash dividends - \$.08 per share	-	-	(.3)	(26.9)	-	-	-	(27.2)
Dividends paid to noncontrolling interest	-	-	-	-	-	-	(37.7)	(37.7)
Other comprehensive loss, net	-	-	-	-	(14.5)	-	(5.4)	(19.9)
Equity transactions with noncontrolling interest, net	-	-	.3	(3.2)	-	-	.6	(2.3)
<b>Balance at December 31, 2019</b>	<b><u>\$ 667.3</u></b>	<b><u>\$ 3.6</u></b>	<b><u>\$ -</u></b>	<b><u>\$ 239.4</u></b>	<b><u>\$ (220.7)</u></b>	<b><u>\$ (49.6)</u></b>	<b><u>\$ 340.1</u></b>	<b><u>\$ 980.1</u></b>

See accompanying Notes to Consolidated Financial Statements.

**VALHI, INC. AND SUBSIDIARIES**  
**CONSOLIDATED STATEMENTS OF CASH FLOWS**  
(In millions)

	<b>Years ended December 31,</b>		
	<b>2017</b>	<b>2018</b>	<b>2019</b>
Cash flows from operating activities:			
Net income	\$ 302.6	\$ 301.0	\$ 78.2
Depreciation and amortization	59.0	58.4	56.8
Net (gain) loss from:			
Sale of business	-	(58.4)	(3.0)
Land sales	-	(12.5)	(4.4)
Securities transactions, net	(1.1)	(12.4)	(3)
Disposal of property and equipment, net	.5	.3	.3
Noncash interest expense	2.5	2.0	2.4
Benefit plan expense greater than cash funding	10.5	5.7	8.9
Deferred income taxes	(293.2)	(73.5)	7.4
Loss on prepayment of debt	7.1	-	-
Payment for termination of interest rate swap contract	(3.3)	-	-
Long-lived asset impairment	170.6	-	-
Distributions from (contributions to) TiO <sub>2</sub> manufacturing joint venture, net	(6.0)	4.0	(9.3)
Other, net	-	13.9	7.7
Change in assets and liabilities:			
Accounts and other receivables, net	(47.5)	(11.1)	8.6
Land held for development, net	6.6	7.8	1.1
Inventories, net	(5.5)	(137.3)	(8.5)
Accounts payable and accrued liabilities	12.9	65.7	(14.6)
Income taxes	19.5	(18.2)	(1.4)
Accounts with affiliates	35.2	19.5	(1.2)
Other noncurrent assets	(.9)	2.6	(6.1)
Other noncurrent liabilities	3.7	13.0	54.2
Other, net	(14.9)	(5.0)	.4
Net cash provided by operating activities	<u>259.3</u>	<u>165.5</u>	<u>177.2</u>

**VALHI, INC. AND SUBSIDIARIES**  
**CONSOLIDATED STATEMENTS OF CASH FLOWS (CONTINUED)**  
(In millions)

	Years ended December 31,		
	2017	2018	2019
Cash flows from investing activities:			
Capital expenditures	\$ (71.3)	\$ (61.4)	\$ (59.9)
Proceeds from sale of business	-	-	2.9
Cash, cash equivalents and restricted cash and cash equivalents of business at time of sale	-	(28.9)	(.5)
Capitalized permit costs	(2.2)	-	-
Purchases of marketable securities	(9.7)	(4.4)	(4.9)
Proceeds from land sales	-	19.5	4.6
Proceeds from disposal of marketable securities	9.0	18.2	4.3
Other, net	(2)	-	2.8
Net cash used in investing activities	(74.4)	(57.0)	(50.7)
Cash flows from financing activities:			
Indebtedness:			
Borrowings	748.1	-	14.9
Principal payments	(600.2)	(12.6)	(11.2)
Deferred financing costs paid	(9.0)	-	-
Valhi cash dividends paid	(27.2)	(27.1)	(27.1)
Distributions to noncontrolling interest in subsidiaries	(18.1)	(20.1)	(37.6)
Subsidiary treasury stock acquired	-	-	(3.1)
Net cash provided by (used in) financing activities	93.6	(59.8)	(64.1)
Cash, cash equivalents and restricted cash and cash equivalents - net change from operating, investing and financing activities	278.5	48.7	62.4
Effect of exchange rates on cash	14.4	(14.4)	(2.3)
Net change for the year	292.9	34.3	60.1
Balance at beginning of year	196.5	489.4	523.7
Balance at end of year	\$ 489.4	\$ 523.7	\$ 583.8
Supplemental disclosures:			
Cash paid for:			
Interest, net of amounts capitalized	\$ 59.3	\$ 53.9	\$ 37.9
Income taxes, net	62.3	68.5	33.4
Noncash investing activities:			
Changes in accruals for capital expenditures	9.4	5.4	9.1
Sale of investment in Amalgamated Sugar Company LLC	-	250.0	-
Receivable from sale of business	-	-	.3
Noncash financing activities:			
Trade payable to affiliate converted to indebtedness	-	36.3	-
Deemed repayment of Snake River Sugar Company indebtedness	-	(250.0)	-
Borrowings paid directly to lender to settle refinanced indebtedness	9.3	-	-
Principal payments paid directly by lender	(8.4)	-	-
Borrowings paid directly to lender for debt issuance costs	(9)	-	-

See accompanying Notes to Consolidated Financial Statements.

**VALHI, INC. AND SUBSIDIARIES**  
**NOTES TO CONSOLIDATED FINANCIAL STATEMENTS**  
**December 31, 2019**

**Note 1—Summary of significant accounting policies:**

**Nature of our business.** Valhi, Inc. (NYSE: VHI) is primarily a holding company. We operate through our wholly-owned and majority-owned subsidiaries, including NL Industries, Inc., Kronos Worldwide, Inc., CompX International Inc., Tremont LLC, Basic Management, Inc. (“BMI”) and The LandWell Company (“LandWell”). Kronos (NYSE: KRO), NL (NYSE: NL) and CompX (NYSE American: CIX) each file periodic reports with the Securities and Exchange Commission (“SEC”). In January 2018, we sold Waste Control Specialists LLC (“WCS”), see Note 3.

**Organization.** We are majority owned by a wholly-owned subsidiary of Contran Corporation (“Contran”), which owns approximately 92% of our outstanding common stock at December 31, 2019. A majority of Contran's outstanding voting stock is held directly by Lisa K. Simmons and Serena Simmons Connelly and various family trusts established for the benefit of Ms. Simmons and Ms. Connelly and their children and for which Ms. Simmons or Ms. Connelly, as applicable, serves as trustee. In addition, each of Ms. Simmons and Ms. Connelly serves as co-chair of the Contran board of directors. The remainder of Contran’s outstanding voting stock is held by another trust (the “Family Trust”), which was established for the benefit of Ms. Simmons and Ms. Connelly and their children and for which a third-party financial institution serves as trustee. Consequently, at December 31, 2019, Ms. Simmons, Ms. Connelly and the Family Trust may be deemed to control Contran, and us.

Unless otherwise indicated, references in this report to “we,” “us” or “our” refer to Valhi, Inc. and its subsidiaries, taken as a whole.

**Management’s estimates.** The preparation of our Consolidated Financial Statements in conformity with accounting principles generally accepted in the United States of America (“GAAP”), requires us to make estimates and assumptions that affect the reported amounts of our assets and liabilities and disclosures of contingent assets and liabilities at each balance sheet date and the reported amounts of our revenues and expenses during each reporting period. Actual results may differ significantly from previously-estimated amounts under different assumptions or conditions.

**Principles of consolidation.** Our Consolidated Financial Statements include the financial position, results of operations and cash flows of Valhi and our majority-owned and wholly-owned subsidiaries. We eliminate all material intercompany accounts and balances. Changes in ownership are accounted for as equity transactions with no gain or loss recognized on the transaction unless there is a change in control. See Note 3.

**Foreign currency translation.** The financial statements of our foreign subsidiaries are translated to U.S. dollars. The functional currency of our foreign subsidiaries is generally the local currency of the country. Accordingly, we translate the assets and liabilities at year-end rates of exchange, while we translate their revenues and expenses at average exchange rates prevailing during the year. We accumulate the resulting translation adjustments in stockholders’ equity as part of accumulated other comprehensive income (loss), net of related deferred income taxes and noncontrolling interest. We recognize currency transaction gains and losses in income.

**Derivatives and hedging activities.** We recognize derivatives as either an asset or liability measured at fair value. We recognize the effect of changes in the fair value of derivatives either in net income or other comprehensive income (loss), depending on the intended use of the derivative. See Note 19.

**Cash and cash equivalents.** We classify bank time deposits and highly-liquid investments with original maturities of three months or less as cash equivalents.

**Restricted cash and cash equivalents.** We classify cash and cash equivalents that have been segregated or are otherwise limited in use as restricted. Such restrictions principally include amounts pledged as collateral with respect to performance obligations or letters of credit required by regulatory agencies for various environmental remediation sites, cash held in escrow under various hold-back agreements with third-party homebuilders associated with our Real Estate Management and Development Segment and cash pledged under debt agreement covenants or legal settlements. To the extent the restricted amount relates to a recognized liability, we classify the restricted amount as current or noncurrent according to the corresponding liability. To the extent the restricted amount does not relate to a recognized liability, we classify restricted cash as a current asset. Restricted cash and cash equivalents classified as a current asset are presented separately on our Consolidated Balance Sheets, and restricted cash and cash equivalents classified as a noncurrent asset are presented as a component of other assets on our Consolidated Balance Sheets, as disclosed in Note 7.

**Marketable securities and securities transactions.** We carry marketable debt and equity securities at fair value. ASC Topic 820, *Fair Value Measurements and Disclosures*, establishes a consistent framework for measuring fair value and (with certain exceptions) this framework is generally applied to all financial statement items required to be measured at fair value. The standard requires fair value measurements to be classified and disclosed in one of the following three categories:

- *Level 1*—Unadjusted quoted prices in active markets that are accessible at the measurement date for identical, unrestricted assets or liabilities;
- *Level 2*—Quoted prices in markets that are not active, or inputs which are observable, either directly or indirectly, for substantially the full term of the assets or liability; and
- *Level 3*—Prices or valuation techniques that require inputs that are both significant to the fair value measurement and unobservable.

We classify all of our marketable securities as available-for-sale. Prior to 2018, any unrealized gains or losses on the securities were recognized through other comprehensive income, net of deferred income taxes. Beginning on January 1, 2018 with the adoption of ASU 2016-01, *Financial Instruments – Overall (Subtopic 825-10): Recognition of Financial Assets and Financial Liabilities*, all of our marketable equity securities will continue to be carried at fair value as noted above, but any unrealized gains or losses on the securities are now recognized in Marketable equity securities on our Consolidated Statements of Income. See Notes 6 and 19. We base realized gains and losses upon the specific identification of the securities sold.

**Accounts receivable.** We provide an allowance for doubtful accounts for known and estimated potential losses arising from our sales to customers based on a periodic review of these accounts.

**Inventories and cost of sales.** We state inventories at the lower of cost or net realizable value. We generally base inventory costs for all inventory categories on average cost that approximates the first-in, first-out method. Inventories include the costs for raw materials, the cost to manufacture the raw materials into finished goods and overhead. Depending on the inventory's stage of completion, our manufacturing costs can include the costs of packing and finishing, utilities, maintenance, depreciation, shipping and handling, and salaries and benefits associated with our manufacturing process. We allocate fixed manufacturing overhead costs based on normal production capacity. Unallocated overhead costs resulting from periods with abnormally low production levels are charged to expense as incurred. As inventory is sold to third parties, we recognize the cost of sales in the same period the sale occurs. We periodically review our inventory for estimated obsolescence or instances when inventory is no longer marketable for its intended use, and we record any write-down equal to the difference between the cost of inventory and its estimated net realizable value based on assumptions about alternative uses, market conditions and other factors.

**Land held for development.** Land held for development relates to BMI and LandWell. The primary asset of LandWell is certain real property in Henderson, Nevada some of which we are developing for residential lots in a master planned community. Land held for development was recorded at the estimated acquisition date fair value based on a value per developable acre at the time of purchase. Development costs, including infrastructure improvements, real estate taxes, capitalized interest and other costs, some of which may be allocated, are capitalized during the period incurred. We allocate costs to each parcel sold on a pro-rata basis associated with the relevant development activity, and the land basis of parcels expected to be sold within one year are presented separately in current assets on our Consolidated Balance Sheets. As land parcels are sold, costs of land sales, including land and development costs, are allocated based on specific identification, relative sales value, square footage or a combination of these methods. All sales and marketing activities and general overhead are charged to selling, general and administrative expense as incurred.

**Investment in TiO<sub>2</sub> manufacturing joint venture.** We account for our investment in a 50%-owned manufacturing joint venture by the equity method. Distributions received from such investee are classified for statement of cash flow purposes using the "nature of distribution" approach under ASC Topic 230. See Note 7.

**Leases.** We enter into various arrangements (or leases) that convey the rights to use and control identified underlying assets for a period of time in exchange for consideration. We lease various manufacturing facilities, land and equipment. From time to time, we may also enter into an arrangement in which the right to use and control an identified underlying asset is embedded in another type of contract.

On January 1, 2019 we adopted ASU 2016-02, *Leases (Topic 842)*. See Notes 7 and 20. We determine if an arrangement is a lease (including leases embedded in another type of contract) at inception. All of our leases are classified as operating leases under this new ASU. Operating leases are included in operating lease right-of-use assets, current operating lease liabilities and noncurrent operating lease liabilities in our Consolidated Balance Sheet beginning January 1, 2019. See Note 7. This ASU permits companies to elect certain practical expedients upon adoption, and at adoption we elected the package of practical expedients related to, among other things, lease classification (in which existing leases classified as operating leases under prior GAAP are classified as an



operating lease under the new ASU, and existing leases classified as a capital lease under prior GAAP are classified as a finance lease under the new ASU), nonlease components (in which nonlease components associated with a lease and paid by us to the lessor, such as property taxes, insurance and maintenance, are treated as a lease component and considered part of minimum lease rental payments), and short-term leases (in which leases with an original maturity of 12 months or less are excluded from the recognition requirements of the new ASU).

Right-of-use assets represent our right to use an underlying asset for the lease term and operating lease liabilities represent our obligation to make lease payments arising from the lease. For leases in effect as of the January 1, 2019 date of adoption of the new ASU, the right-of-use operating lease assets and liabilities were recognized based on the estimated present value of remaining lease payments over the remaining lease term as of the adoption date. For new leases entered into subsequent to the date of adoption of the new ASU, the right-of-use operating lease assets and liabilities are recognized based on the estimated present value of lease payments over the lease term as of the respective lease commencement dates.

We use an estimated incremental borrowing rate to determine the present value of lease payments (unless we can determine the rate implicit in the lease, which is generally not the case). Our incremental borrowing rate for each of our leases is derived from available information, including our current debt and credit facilities and U.S. and European yield curves as well as publicly available data for instruments with similar characteristics, adjusted for factors such as collateralization and term. For leases in effect as of the January 1, 2019 date of adoption of the new ASU, we used an estimated incremental borrowing rate for each lease on the date of adoption. For new leases entered into subsequent to the date of adoption of the new ASU, we use an estimated incremental borrowing rate for each lease as of the respective lease commencement date.

Our leases generally do not include termination or purchase options. Certain of our leases include an option to renew the lease after expiration of the initial lease term, but we have not included such renewal periods in our lease term because it is not reasonably certain that we would exercise the renewal option. Our leases generally have fixed lease payments, with no contingent or incentive payments. Certain of our leases include variable lease payments that depend on a specified index or rate, and in accordance with ASU 2016-02 the determination of the operating lease liabilities is based on the index or rate existing at the date of adoption of the new ASU (for leases in effect as of January 1, 2019) or the index or rate in effect as of the lease commencement date (for leases entered into subsequent to the date of adoption of the new ASU). Our lease agreements do not contain any residual value guarantees.

**Goodwill and other intangible assets; amortization expense.** Goodwill represents the excess of cost over fair value of individual net assets acquired in business combinations. Goodwill is not subject to periodic amortization. We amortize other intangible assets by the straight-line method over their estimated lives and state them net of accumulated amortization. We evaluate goodwill for impairment, annually or when events or changes in circumstances indicate the carrying value may not be recoverable. We evaluate other intangible assets for impairment when events or changes in circumstances indicate the carrying value may not be recoverable. See Note 8.

**Property and equipment; depreciation expense.** We state property and equipment at acquisition cost, including capitalized interest on borrowings during the actual construction period of major capital projects. In 2017, 2018 and 2019 we capitalized \$2.2 million, \$1.1 million and \$.8 million, respectively, of interest costs. We compute depreciation of property and equipment for financial reporting purposes (including mining equipment) principally by the straight-line method over the estimated useful lives of the assets as follows:

Asset	Useful lives
Buildings and improvements	10 to 40 years
Machinery and equipment	3 to 20 years
Mine development costs	Units-of-production

We use accelerated depreciation methods for income tax purposes, as permitted. Upon the sale or retirement of an asset, we remove the related cost and accumulated depreciation from the accounts and recognize any gain or loss in income currently.

We expense expenditures for maintenance, repairs and minor renewals as incurred that do not improve or extend the life of the assets, including planned major maintenance.

We have a governmental concession with an unlimited term to operate our ilmenite mines in Norway. Mining properties consist of buildings and equipment used in our Norwegian ilmenite mining operations. While we own the land and ilmenite reserves associated with the mining operations, such land and reserves were acquired for nominal value and we have no material asset recognized for the land and reserves related to our mining operations.

We perform impairment tests when events or changes in circumstances indicate the carrying value may not be recoverable. We consider all relevant factors. We perform the impairment test by comparing the estimated future undiscounted cash flows (exclusive of interest expense) associated with the asset or asset group to the asset's net carrying value to determine if a write-down to fair value is required.

**Long-term debt.** We state long-term debt net of any unamortized original issue premium, discount or deferred financing costs (other than deferred financing costs associated with revolving credit facilities, which are recognized as an asset). We classify amortization of deferred financing costs and any premium or discount associated with the issuance of indebtedness as interest expense, and compute amortization by either the interest method or the straight-line method over the term of the applicable issue. See Note 9.

**Employee benefit plans.** Accounting and funding policies for our defined benefit pension and defined contribution retirement plans are described in Note 11. We also provide certain postretirement benefits other than pensions (OPEB), consisting of health care and life insurance benefits, to certain U.S. and Canadian retired employees, which are not material. See Note 10.

**Income taxes.** We and our qualifying subsidiaries are members of Contran's consolidated U.S. federal income tax group (the "Contran Tax Group"). We and certain of our qualifying subsidiaries also file consolidated income tax returns with Contran in various U.S. state jurisdictions. As a member of the Contran Tax Group, we are jointly and severally liable for the federal income tax liability of Contran and the other companies included in the Contran Tax Group for all periods in which we are included in the Contran Tax Group. See Note 17. As a member of the Contran Tax Group, we are a party to a tax sharing agreement which provides that we compute our tax provision for U.S. income taxes on a separate-company basis using the tax elections made by Contran. Pursuant to the tax sharing agreement, we make payments to or receive payments from Contran in amounts we would have paid to or received from the U.S. Internal Revenue Service or the applicable state tax authority had we not been a member of the Contran Tax Group. We made net cash payments for income taxes to Contran of \$38.9 million in 2017, received \$5.8 million in cash payments for income taxes from Contran in 2018 and made \$7.4 million in cash payments for income taxes to Contran in 2019.

We recognize deferred income tax assets and liabilities for the expected future tax consequences of temporary differences between the income tax and financial reporting carrying amounts of assets and liabilities, including investments in our subsidiaries and affiliates who are not members of the Contran Tax Group and undistributed earnings of our Chemicals Segment's non-U.S. subsidiaries which are not deemed to be permanently reinvested. At December 31, 2019, we continue to assert indefinite reinvestment as it relates to our outside basis difference attributable to our Chemicals Segment's investments in non-U.S. subsidiaries, other than post-1986 undistributed earnings of our Chemicals Segment's European subsidiaries and all undistributed earnings of our Chemicals Segment's Canadian subsidiary, which are not subject to permanent reinvestment plans. It is not practical for us to determine the amount of the unrecognized deferred income tax liability related to our investments in our Chemicals Segment's non-U.S. subsidiaries which are permanently reinvested due to the complexities associated with our organizational structure, changes in the Tax Cuts and Jobs Act (2017 Tax Act) enacted on December 22, 2017, and the U.S. taxation of such investments in the states in which we operate. Deferred income tax assets and liabilities for each tax-paying jurisdiction in which we operate are netted and presented as either a noncurrent deferred income tax asset or liability, as applicable. We periodically evaluate our deferred tax assets in the various taxing jurisdictions in which we operate and adjust any related valuation allowance based on the estimate of the amount of such deferred tax assets that we believe does not meet the more-likely-than-not recognition criteria.

We account for the tax effects of a change in tax law as a component of the income tax provision related to continuing operations in the period of enactment, including the tax effects of any deferred income taxes originally established through a financial statement component other than continuing operations (i.e. other comprehensive income). Changes in applicable income tax rates over time as a result of changes in tax law, or times in which a deferred income tax asset valuation allowance is initially recognized in one year and subsequently reversed in a later year, can give rise to "stranded" tax effects in accumulated other comprehensive income in which the net accumulated income tax (benefit) remaining in accumulated other comprehensive income does not correspond to the then-applicable income tax rate applied to the pre-tax amount which resides in accumulated other comprehensive income. As permitted by GAAP, our accounting policy is to remove any such stranded tax effect remaining in accumulated other comprehensive income, by recognizing an offset to our provision for income taxes related to continuing operations, only at the time when there is no remaining pre-tax amount in accumulated other comprehensive income. For accumulated other comprehensive income related to currency translation, this would occur only upon the sale or complete liquidation of one of our Chemicals Segment's non-U.S. subsidiaries. For defined pension benefit plans and OPEB plans, this would occur whenever one of our subsidiaries which previously sponsored a defined benefit pension or OPEB plan had terminated such a plan and had no future obligation or plan asset associated with such a plan.

We record a reserve for uncertain tax positions where we believe it is more-likely-than-not our position will not prevail with the applicable tax authorities. The amount of the benefit associated with our uncertain tax positions that we recognize is limited to the largest amount for which we believe the likelihood of realization is greater than 50%. We accrue penalties and interest on the difference between tax positions taken on our tax returns and the amount of benefit recognized for financial reporting purposes. We classify our reserves for uncertain tax positions in a separate current or noncurrent liability, depending on the nature of the tax position. See Note 14.

***Environmental remediation and related costs.*** We record liabilities related to environmental remediation and related costs when estimated future expenditures are probable and reasonably estimable. We adjust these accruals as further information becomes available to us or as circumstances change. We generally do not discount estimated future expenditures to their present value due to the uncertainty of the timing of the ultimate payout. We recognize any recoveries of remediation costs from other parties when we deem their receipt to be probable. We expense any environmental remediation related legal costs as incurred. At December 31, 2018, we had accrued insurance recoveries of \$15.0 million and at December 31, 2019 we had not recognized any material receivables for recoveries. See Note 18.

***Revenue recognition. Chemicals and Component Products Segments*** - Our sales involve single performance obligations to ship our products pursuant to customer purchase orders. In some cases, the purchase order is supported by an underlying master sales agreement, but our purchase order acceptance generally evidences the contract with our customer by specifying the key terms of product and quantity ordered, price and delivery and payment terms. Effective January 1, 2018 with the adoption of ASU No. 2014-09, *Revenue from Contracts with Customers (Topic 606)*, see Note 12, we record revenue when we satisfy our performance obligations to our customers by transferring control of our products to them, which generally occurs at point of shipment or upon delivery. Such transfer of control is also evidenced by transfer of legal title and other risks and rewards of ownership (giving the customer the ability to direct the use of, and obtain substantially all of the benefits of, the product), and our customers becoming obligated to pay us and it is probable we will receive payment. In certain arrangements we provide shipping and handling activities after the transfer of control to our customer (e.g. when control transfers prior to delivery). In such arrangements shipping and handling are considered fulfillment activities, and accordingly, such costs are accrued when the related revenue is recognized. Prior to the adoption of ASU 2014-09, we recorded sales when our products were shipped and title and other risks and rewards of ownership had passed to the customer, which was generally at the time of shipment (although in some instances shipping terms were FOB destination point, for which we did not recognize revenue until the product was received by our customer).

Revenue is recorded in an amount that reflects the net consideration we expect to receive in exchange for our products. Prices for our products are based on terms specified in published list prices and purchase orders, which generally do not include financing components, noncash consideration or consideration paid to our customers. As our standard payment terms are less than one year, we have elected the practical expedient under ASU 2014-09 and we have not assessed whether a contract has a significant financing component. We state sales net of price, early payment and distributor discounts as well as volume rebates (collectively, variable consideration). Variable consideration, to the extent present, is recognized as the amount to which we are most-likely to be entitled, using all information (historical, current and forecasted) that is reasonably available to us, and only to the extent that a significant reversal in the amount of the cumulative revenue recognized is not probable of occurring in a future period. Differences, if any, between estimates of the amount of variable consideration to which we will be entitled and the actual amount of such variable consideration have not been material in the past. We report any tax assessed by a governmental authority that we collect from our customers that is both imposed on and concurrent with our revenue-producing activities (such as sales, use, value added and excise taxes) on a net basis (meaning we do not recognize these taxes either in our revenues or in our costs and expenses).

Frequently, we receive orders for products to be delivered over dates that may extend across reporting periods. We invoice for each delivery upon shipment and recognize revenue for each distinct shipment when all sales recognition criteria for that shipment have been satisfied. As scheduled delivery dates for these orders are within a one year period, under the optional exemption provided by ASU 2014-09, we do not disclose sales allocated to future shipments of partially completed contracts.

***Real Estate Management and Development Segment*** – Revenues from our Real Estate Management and Development Segment are generally not material. Our sales involve providing utility services, among other things, to an industrial park located in Henderson, Nevada and we are responsible for the delivery of water to the City of Henderson and various other users through a water distribution system we own. These sales involve single performance obligations and we record revenue when we satisfy our performance obligations to our customers generally after the service is performed and our customers become obligated to pay us and it is probable we will receive payment. Revenue is recorded in an amount that reflects the net consideration we expect to receive in exchange for our services. Prices for our products are based on contracted rates and do not include financing components, noncash consideration or consideration paid to our customers. As our standard payment terms are less than one year, we have elected the practical expedient under ASC 606 and we have not assessed whether a contract has a significant financing component.

Our revenues also are related to efforts to develop certain real estate in Henderson, Nevada, including approximately 2,100 acres zoned for residential/planned community purposes and approximately 400 acres zoned for commercial and light industrial use. Contracts for land sales are negotiated on an individual basis, involve single performance obligations, and generally require us to complete property development and improvements after title passes to the buyer and we have received all or a substantial portion of the selling price. We recognize land sales revenue associated with the residential/planned community over time using cost based input methods. Land sales associated with the residential/planned community have variable consideration components which are based on a percentage of the builder's ultimate selling price of a residential housing unit to their customer (generally 3.5% of such sales price). The amount we recognize when a parcel is sold to a home builder is the amount to which we are most-likely to be entitled, using all information (historical, current and forecasted) that is reasonably available to us, and only to the extent that a significant reversal in the amount of the cumulative revenue recognized is not probable of occurring in a future period. By recognizing revenue over time using cost based input methods, revenues (including variable consideration) and profits are recognized in the same proportion of our progress towards completion of our contractual obligations, with our progress measured by costs incurred as a percentage of total costs estimated to be incurred relative to the parcels sold. Estimates of total costs expected to be incurred require significant management judgment, and the amount of revenue and profits that have been recognized to date are subject to revisions throughout the development period. The impact on the amount of revenue recognized resulting from any future change in the estimate of total costs estimated to be incurred would be accounted for prospectively in accordance with GAAP. We record estimated deferred revenue on the amount to which we are most-likely to be entitled and deferred revenue is recognized into revenue as the housing units are sold. Prior to the adoption of ASU 2014-09, we did not include variable consideration in the percentage-of-completion method of revenue recognition.

***Selling, general and administrative expenses; shipping and handling costs; advertising costs; research and development costs.*** Selling, general and administrative expenses include costs related to marketing, sales, distribution, shipping and handling, research and development, legal, environmental remediation and administrative functions such as accounting, treasury and finance, and includes costs for salaries and benefits not associated with our manufacturing process, travel and entertainment, promotional materials and professional fees. Shipping and handling costs of our Chemicals Segment were approximately \$101 million in 2017, \$105 million in 2018 and \$111 million in 2019. Shipping and handling costs of our Component Products segment are not material. We expense advertising and research and development costs as incurred. Advertising costs were approximately \$1 million in each of 2017 and 2018 and approximately \$2 million in 2019. Research, development and certain sales technical support costs were approximately \$19 million in 2017, \$16 million in 2018 and \$17 million in 2019.

**Note 2—Business and geographic segments:**

<b>Business segment</b>	<b>Entity</b>	<b>% controlled at December 31 2019</b>
Chemicals	Kronos	80%
Component products	CompX	86%
Real estate management and development	BMI and LandWell	63% - 77%

Our control of Kronos includes 50% we hold directly and 30% held directly by NL. We own 83% of NL. Our control of CompX is through NL. We own 63% of BMI. Our control of LandWell includes the 27% we hold directly and 50% held by BMI. See Note 3.

We are organized based upon our operating subsidiaries. Our operating segments are defined as components of our consolidated operations about which separate financial information is available that is regularly evaluated by our chief operating decision maker in determining how to allocate resources and in assessing performance. Each operating segment is separately managed and each operating segment represents a strategic business unit offering different products.

We have the following three consolidated reportable operating segments.

- *Chemicals*—Our chemicals segment is operated through our majority control of Kronos. Kronos is a leading global producer and marketer of value-added titanium dioxide pigments (“TiO<sub>2</sub>”). TiO<sub>2</sub> is used to impart whiteness, brightness, opacity and durability to a wide variety of products, including paints, plastics, paper, fibers and ceramics. Additionally, TiO<sub>2</sub> is a critical component of everyday applications, such as coatings, plastics and paper, as well as many specialty products such as inks, foods and cosmetics. See Note 7.
- *Component Products*—We operate in the component products industry through our majority control of CompX. CompX is a leading manufacturer of security products used in the recreational transportation, postal, office and institutional furniture, tool storage, healthcare and a variety of other industries. CompX is also a leading manufacturer of stainless steel exhaust systems, gauges, throttle controls, wake enhancement systems and trim tabs for the recreational marine industry. All of CompX production facilities are in the United States.
- *Real Estate Management and Development*—We operate in real estate management and development through our majority control of BMI and LandWell. BMI provides utility services to certain industrial and municipal customers and owns real property in Henderson, Nevada. LandWell is engaged in efforts to develop certain land holdings for commercial, industrial and residential purposes in Henderson, Nevada.

We evaluate segment performance based on segment operating income, which we define as income before income taxes and interest expense, exclusive of certain non-recurring items (such as gains or losses on disposition of business units and other long-lived assets outside the ordinary course of business and certain legal settlements) and certain general corporate income and expense items (including securities transactions gains and losses and interest and dividend income), which are not attributable to the operations of the reportable operating segments. The accounting policies of our reportable operating segments are the same as those described in Note 1. Segment results we report may differ from amounts separately reported by our various subsidiaries and affiliates due to purchase accounting adjustments and related amortization or differences in how we define operating income. Intersegment sales are not material.

Interest income included in the calculation of segment operating income is not material in 2017, 2018 or 2019. Capital expenditures include additions to property and equipment but exclude amounts we paid for business units acquired in business combinations. Depreciation and amortization related to each reportable operating segment includes amortization of any intangible assets attributable to the segment. Amortization of deferred financing costs and any premium or discount associated with the issuance of indebtedness is included in interest expense.

Segment assets are comprised of all assets attributable to each reportable operating segment, including goodwill and other intangible assets. Our investment in the TiO<sub>2</sub> manufacturing joint venture (see Note 7) is included in the Chemicals Segment’s assets. Corporate assets are not attributable to any operating segment and consist principally of cash and cash equivalents, restricted cash and restricted cash equivalents and marketable securities.

	Years ended December 31,		
	2017	2018	2019
	(In millions)		
Net sales:			
Chemicals	\$ 1,729.0	\$ 1,661.9	\$ 1,731.2
Component products	112.0	118.2	124.2
Real estate management and development	38.4	40.0	42.1
Total net sales	<u>\$ 1,879.4</u>	<u>\$ 1,820.1</u>	<u>\$ 1,897.5</u>
Cost of sales:			
Chemicals	\$ 1,161.2	\$ 1,101.7	\$ 1,346.8
Component products	77.2	79.9	85.3
Real estate management and development	28.1	29.3	30.8
Total cost of sales	<u>\$ 1,266.5</u>	<u>\$ 1,210.9</u>	<u>\$ 1,462.9</u>
Gross margin:			
Chemicals	\$ 567.8	\$ 560.2	\$ 384.4
Component products	34.8	38.3	38.9
Real estate management and development	10.3	10.7	11.3
Total gross margin	<u>\$ 612.9</u>	<u>\$ 609.2</u>	<u>\$ 434.6</u>
Operating income:			
Chemicals	\$ 358.5	\$ 342.9	\$ 160.1
Component products	15.2	17.8	17.8
Real estate management and development	6.6	10.0	14.8
Total operating income	<u>380.3</u>	<u>370.7</u>	<u>192.7</u>
General corporate items:			
Securities earnings	29.5	38.5	11.2
Insurance recoveries	.4	1.3	7.7
Gain on land sales	-	12.5	4.4
Gain on sale of business	-	-	3.0
Other components of net periodic pension expense	(17.7)	(14.5)	(16.5)
Litigation settlement expense, net	-	(62.0)	(19.3)
Changes in market value of Valhi common stock held by subsidiaries	-	(12.2)	(.2)
General expenses, net	(34.7)	(42.4)	(37.5)
Loss on prepayment of debt	(7.1)	-	-
Interest expense	<u>(58.9)</u>	<u>(55.7)</u>	<u>(40.8)</u>
Income from continuing operations before income taxes	<u>\$ 291.8</u>	<u>\$ 236.2</u>	<u>\$ 104.7</u>

	Years ended December 31,		
	2017	2018	2019
	(In millions)		
Depreciation and amortization:			
Chemicals	\$ 43.4	\$ 52.0	\$ 50.2
Component products	3.7	3.5	3.7
Waste management <sup>(1)</sup>	8.9	-	-
Real estate management and development	3.0	2.9	2.9
Total	<u>\$ 59.0</u>	<u>\$ 58.4</u>	<u>\$ 56.8</u>
Capital expenditures:			
Chemicals	\$ 64.3	\$ 56.3	\$ 55.1
Component products	2.8	3.1	3.2
Waste management <sup>(1)</sup>	.9	.1	-
Real estate management and development	3.3	1.9	1.6
Total	<u>\$ 71.3</u>	<u>\$ 61.4</u>	<u>\$ 59.9</u>

	<b>December 31,</b>		
	<b>2017</b>	<b>2018</b>	<b>2019</b>
	<b>(In millions)</b>		
Total assets:			
Operating segments:			
Chemicals	\$ 2,190.5	\$ 2,266.6	\$ 2,331.8
Component products	104.9	120.4	132.5
Waste management <sup>(1)</sup>	52.0	-	-
Real estate management and development	206.9	218.5	191.6
Corporate and eliminations	353.2	104.1	138.5
Total	<u>\$ 2,907.5</u>	<u>\$ 2,709.6</u>	<u>\$ 2,794.4</u>

<sup>(1)</sup>Denotes discontinued operations

*Geographic information.* We attribute net sales to the place of manufacture (point-of-origin) and the location of the customer (point-of-destination); we attribute property and equipment to their physical location. At December 31, 2019 the net assets of our non-U.S. subsidiaries included in consolidated net assets approximated \$563 million (in 2018 the total was \$614 million).

	<b>Years ended December 31,</b>		
	<b>2017</b>	<b>2018</b>	<b>2019</b>
	<b>(In millions)</b>		
Net sales - point of origin:			
United States	\$ 992.3	\$ 997.6	\$ 1,164.8
Germany	918.6	886.1	883.6
Canada	309.2	307.2	328.7
Belgium	279.9	272.2	270.7
Norway	216.4	209.6	192.2
Eliminations	(837.0)	(852.6)	(942.5)
Total	<u>\$ 1,879.4</u>	<u>\$ 1,820.1</u>	<u>\$ 1,897.5</u>
Net sales - point of destination:			
North America	\$ 668.3	\$ 698.7	\$ 740.1
Europe	899.2	817.6	824.2
Asia and other	311.9	303.8	333.2
Total	<u>\$ 1,879.4</u>	<u>\$ 1,820.1</u>	<u>\$ 1,897.5</u>

	<b>December 31,</b>		
	<b>2017</b>	<b>2018</b>	<b>2019</b>
	<b>(In millions)</b>		
Net property and equipment:			
United States	\$ 80.8	\$ 74.5	\$ 72.0
Germany	259.2	245.8	233.6
Canada	69.0	66.1	73.1
Norway	81.7	81.0	87.9
Belgium	98.0	96.1	96.4
Total	<u>\$ 588.7</u>	<u>\$ 563.5</u>	<u>\$ 563.0</u>

**Note 3—Business combinations, dispositions and related transactions:**

*Kronos Worldwide, Inc.*

Prior to 2017, Kronos' board of directors authorized the repurchase of up to 2.0 million shares of its common stock in open market transactions, including block purchases, or in privately-negotiated transactions at unspecified prices and over an unspecified period of time. Kronos may repurchase its common stock from time to time as market conditions permit. The stock repurchase program does not include specific price targets or timetables and may be suspended at any time. Depending on market conditions, Kronos may terminate the program prior to its completion. Kronos uses cash on hand or other sources of liquidity to acquire the shares. Repurchased shares are added to Kronos' treasury and cancelled. Kronos did not make any repurchases under the plan during 2017 or 2018. In 2019, Kronos acquired 264,992 shares of its common stock in market transactions for an aggregate purchase price of \$3.0 million and subsequently cancelled all of such shares. At December 31, 2019 approximately 1.69 million shares are available for repurchase under these authorizations.

*CompX International Inc.*

Prior to 2017, CompX's board of directors authorized various repurchases of its Class A common stock in open market transactions, including block purchases, or in privately-negotiated transactions at unspecified prices and over an unspecified period of time. CompX may repurchase its common stock from time to time as market conditions permit. The stock repurchase program does not include specific price targets or timetables and may be suspended at any time. Depending on market conditions, CompX may terminate the program prior to its completion. CompX would generally use cash on hand to acquire the shares. Repurchased shares will be added to CompX's treasury and cancelled. CompX did not make any repurchases under the plan during 2017, 2018 or 2019, and at December 31, 2019 approximately 678,000 shares were available for purchase under these authorizations.

*Discontinued Operations —Waste Control Specialists LLC*

Pursuant to an agreement we entered into in December 2017, on January 26, 2018 we completed the sale of our Waste Management Segment to JFL-WCS Partners, LLC ("JFL Partners"), an entity sponsored by certain investment affiliates of J.F. Lehman & Company, for consideration consisting of the assumption of all of WCS' third-party indebtedness and other liabilities. We recognized a pre-tax gain of approximately \$58 million primarily in the first quarter of 2018 on the transaction (\$34.7 million, or \$1.10 per diluted share, net of tax) because the carrying value of the liabilities of the business assumed by the purchaser exceeded the carrying value of the assets sold at the time of the sale in large part due to the previously-reported long-lived asset impairment of \$170.6 million recognized in the second quarter of 2017 as discussed below. The net assets of the disposed Waste Management Segment at the time we completed the sale on January 26, 2018 were not materially different as compared to December 31, 2017. Our Waste Management Segment, which operated in the low-level radioactive, hazardous, toxic and other waste disposal industry historically struggled to generate sufficient recurring disposal volumes to generate positive operating results or cash flows. The sale enabled us to focus more effort on continuing to develop our remaining segments which we believe have greater opportunity for higher returns.

In accordance with GAAP, the Waste Management Segment has been reclassified as discontinued operations in our Consolidated Statements of Income for the years ended 2017 and 2018. Also in accordance with GAAP, we have not reclassified our Consolidated Statement of Cash Flows to reflect the Waste Management Segment as discontinued operations.



Selected financial data for the operations of the disposed Waste Management Segment for periods prior to completing the sale is presented below.

	<b>Years ended December 31,</b>	
	<b>2017</b>	<b>2018</b>
	<b>(In millions)</b>	
Net sales	\$ 75.4	\$ 4.6
Operating loss	\$ (167.1)	\$ (.4)
Termination fee	4.0	-
Other expense, net	(8.4)	-
Interest expense, net	(4.8)	(.3)
Loss before taxes	(176.3)	(.7)
Income tax benefit	(67.1)	(.1)
Net loss	(109.2)	(.6)
Pre-tax gain on disposal	\$ -	\$ 58.4
Income tax expense	-	23.7
After-tax gain on disposal	-	34.7
Total	\$ (109.2)	\$ 34.1
Net cash provided by operating activities	\$ 18.1	\$ 2.3
Net cash used in investing activities	(3.4)	(.1)

The Waste Management Segment's operating loss in 2017 includes a \$170.6 million long-lived asset impairment which is included in the determination of its operating income. As previously reported, in November 2015 we entered into an agreement with Rockwell Holdco, Inc. ("Rockwell") for the sale of WCS to Rockwell. The agreement, as amended, was for \$270 million in cash plus the assumption of all of WCS' third-party indebtedness incurred prior to the date of the agreement. Additionally, Rockwell and its affiliates would have assumed all financial assurance obligations related to the WCS business. Rockwell is the parent company of EnergySolutions, Inc. Completion of the sale was subject to certain customary closing conditions, including the receipt of U.S. anti-trust approval. The U.S. Department of Justice ("DOJ") did not give the parties anti-trust clearance, and on November 16, 2016, the DOJ filed an anti-trust action in the U.S. federal district court for the District of Delaware styled *United States of America vs. Energy Solutions, Inc., et al* (Case No. 1:16-cv-01056-UNA), seeking an injunction to enjoin completion of the sale of WCS. Trial was held in late April and early May 2017. On June 21, 2017, the court issued an order enjoining the sale of WCS. While we disagreed with the court's decision, the parties determined that they would not appeal the decision to the Third Circuit Court of Appeals, and on June 22, 2017, we provided written notice to Rockwell terminating the purchase agreement for the sale of WCS to Rockwell effective June 22, 2017.

The Court's decision and resulting termination of the purchase agreement with Rockwell constituted triggering events under ASC 360-10-35-21, requiring WCS' long-lived assets to be tested for recoverability. Given the challenges facing WCS' disposal operations we concluded that the long-lived assets associated with WCS' operations were impaired at June 30, 2017, concurrent with the termination of the purchase agreement with Rockwell. Accordingly, we recognized an aggregate \$170.6 million impairment charge as of June 30, 2017, to reduce the carrying value of WCS' long-lived assets recognized for financial reporting purposes to their estimated fair value. Such \$170.6 million impairment charge relates to the following long-lived assets of WCS: net property and equipment - \$127.5 million; waste disposal site operating permits, net - \$42.0 million; and other assets - \$1.1 million. With respect to the operating permits, we concluded such long-lived assets were fully impaired, as these permits are specific to WCS' land and facility in Andrews County and have no salvage value as there is no alternative use for permits. Similarly, with respect to the net property and equipment, we concluded such long-lived assets were fully impaired except to the extent certain items of property and equipment had an alternate use outside of WCS' operations; for those items of property and equipment, they were written down to estimated salvage value, primarily using dealer or auction-site quotes (Level 3 inputs) as the basis for salvage value. At June 30, 2017, the time the impairment was recognized, the salvage value for such items of property and equipment aggregated \$5.7 million.

As part of the terms of the fourth amendment to the purchase agreement with Rockwell, in the event of termination of the purchase agreement for any reason (including termination of the purchase agreement if completion of the sale of WCS is enjoined on anti-trust grounds), we would be entitled to receive a termination fee from Rockwell. Such termination fee (net of applicable expenses) aggregated \$4 million, was received in June 2017 and is recognized as part of loss from discontinued operations in 2017 (classified as part of other expense, net in the table above). Other expense, net in the table above also includes expenses aggregating \$8.7 million in 2017 related to efforts to sell WCS (principally legal fees).

In connection with the January 2018 sale, JFL Partners did not assume WCS' trade payable owed to Contran, which consisted primarily of intercorporate service fees charged to WCS by Contran for which WCS did not pay Contran for several years. Immediately prior to the closing of the sale of WCS, Contran transferred its associated receivable from WCS to Valhi in return for a deemed borrowing by Valhi under its revolving credit facility with Contran. Valhi subsequently contributed such receivable from WCS to WCS's equity, and the trade payable obligation of WCS was deemed paid in full.

**Note 4—Accounts and other receivables, net:**

	December 31,	
	2018	2019
	(In millions)	
Trade accounts receivable:		
Kronos	\$ 273.3	\$ 270.5
CompX	12.2	11.9
BMI/LandWell	1.5	1.6
VAT and other receivables	32.7	31.2
Allowance for doubtful accounts	(1.3)	(1.2)
Total	<u>\$ 318.4</u>	<u>\$ 314.0</u>

**Note 5—Inventories, net:**

	December 31,	
	2018	2019
	(In millions)	
Raw materials:		
Chemicals	\$ 93.1	\$ 124.4
Component products	2.7	2.9
Total raw materials	<u>95.8</u>	<u>127.3</u>
Work in process:		
Chemicals	23.5	39.0
Component products	11.1	11.8
Total in-process products	<u>34.6</u>	<u>50.8</u>
Finished products:		
Chemicals	317.6	270.7
Component products	3.3	3.6
Total finished products	<u>320.9</u>	<u>274.3</u>
Supplies (chemicals)	64.5	69.7
Total	<u>\$ 515.8</u>	<u>\$ 522.1</u>

**Note 6—Marketable securities:**

	<u>Market value</u>	<u>Cost basis</u>	<u>Unrealized gains (losses), net</u>
	(In millions)		
<b>December 31, 2018:</b>			
Current assets	\$ 2.5	\$ 2.5	\$ -
Noncurrent assets	\$ 4.8	\$ 5.2	\$ (.4)
<b>December 31, 2019:</b>			
Current assets	\$ 2.1	\$ 2.1	\$ -
Noncurrent assets	\$ 6.2	\$ 6.2	\$ -

	<u>Fair Value Measurements</u>		
	<u>Total</u>	<u>Quoted prices in active markets (Level 1)</u>	<u>Significant other observable inputs (Level 2)</u>
	(In millions)		
<b>December 31, 2018:</b>			
Current assets	\$ 2.5	\$ -	\$ 2.5
Noncurrent assets:			
Fixed income securities	\$ 3.2	\$ -	\$ 3.2
Common stocks and exchange traded funds	1.6	1.6	-
Total	\$ 4.8	\$ 1.6	\$ 3.2
<b>December 31, 2019:</b>			
Current assets	\$ 2.1	\$ -	\$ 2.1
Noncurrent assets:			
Fixed income securities	\$ 4.9	\$ -	\$ 4.9
Common stocks and exchange traded funds	1.3	1.3	-
Total	\$ 6.2	\$ 1.3	\$ 4.9

*Amalgamated Sugar.* Prior to 2017, we transferred control of the refined sugar operations previously conducted by our wholly-owned subsidiary, The Amalgamated Sugar Company, to Snake River Sugar Company, an Oregon agricultural cooperative formed by certain sugar beet growers in Amalgamated’s areas of operations. Pursuant to the transaction, we contributed substantially all of the net assets of our refined sugar operations to The Amalgamated Sugar Company LLC, a limited liability company controlled by Snake River, on a tax-deferred basis in exchange for a non-voting ownership interest in the LLC. The cost basis of the net assets we transferred to the LLC was approximately \$34 million. When we transferred control of our operations to Snake River in return for our interest in the LLC, we recognized a gain in earnings equal to the difference between \$250 million (the fair value of our investment in the LLC as evidenced by its \$250 million redemption price, as discussed below) and the \$34 million cost basis of the net assets we contributed to the LLC, net of applicable deferred income taxes. Therefore, the cost basis of our investment in the LLC was \$250 million. As part of this transaction, Snake River made certain loans to us aggregating \$250 million. These loans were collateralized by our interest in the LLC. See Note 13. We and Snake River shared in distributions from the LLC up to an aggregate of \$26.7 million per year (the “base” level), with a preferential 95% share going to us. Additionally, Snake River agreed that the annual amount of distributions we received from the LLC would exceed the annual amount of interest payments we owed to Snake River on our \$250 million in loans from Snake River by at least \$1.8 million on an annual basis.

On May 30, 2018, we entered into an agreement with Snake River, completed on August 31, 2018, in which we sold our interest in Amalgamated for consideration consisting of \$12.5 million in cash and the deemed payment in full of our \$250 million in

loans from Snake River. As a result, in the third quarter of 2018 we recognized a securities transaction gain of \$12.5 million related to the sale and our \$250 million in loans were deemed repaid in full.

*Other.* The fair value of our marketable securities are either determined using Level 1 inputs (because the securities are actively traded) or determined using Level 2 inputs (because although these securities are traded, in many cases the market is not active and the year-end valuation is generally based on the last trade of the year, which may be several days prior to December 31).

**Note 7—Investment in TiO<sub>2</sub> manufacturing joint venture and other assets:**

	December 31,	
	2018	2019
	(In millions)	
Other assets:		
Land held for development	\$ 129.2	\$ 125.3
Operating lease right-of-use assets	-	29.0
Restricted cash and cash equivalents	8.9	33.0
Land contract receivables	9.1	-
IBNR receivables	6.0	8.5
Note receivables - OPA	1.9	8.8
Other	12.7	11.9
Total	<u>\$ 167.8</u>	<u>\$ 216.5</u>

**Investment in TiO<sub>2</sub> manufacturing joint venture.** Our Chemicals Segment owns a 50% interest in Louisiana Pigment Company, L.P. (LPC). LPC is a manufacturing joint venture whose other 50%-owner is Venator Investments LLC (Venator Investments). Venator Investments is a wholly-owned subsidiary of Venator Group, of which Venator Materials PLC owns 100% and is the ultimate parent. LPC owns and operates a chloride-process TiO<sub>2</sub> plant near Lake Charles, Louisiana.

Kronos and Venator Investments are both required to purchase one-half of the TiO<sub>2</sub> produced by LPC, unless Kronos and Venator Investments agree otherwise. LPC operates on a break-even basis and, accordingly, we report no equity in earnings of LPC. Each owner's acquisition transfer price for its share of the TiO<sub>2</sub> produced is equal to its share of the joint venture's production costs and interest expense, if any. Kronos' share of net cost is reported as cost of sales as the related TiO<sub>2</sub> acquired from LPC is sold. We report distributions Kronos receives from LPC, which generally relate to excess cash generated by LPC from its non-cash production costs, and contributions Kronos makes to LPC, which generally relate to cash required by LPC when it builds working capital, as part of our cash flows from operating activities in our Consolidated Statements of Cash Flows. The components of our net cash distributions from (contributions to) LPC are shown in the table below.

	Years ended December 31,		
	2017	2018	2019
	(In millions)		
Distributions from LPC	\$ 44.0	\$ 34.3	\$ 40.6
Contributions to LPC	(50.0)	(30.3)	(49.9)
Net distributions (contributions)	<u>\$ (6.0)</u>	<u>\$ 4.0</u>	<u>\$ (9.3)</u>

Summary balance sheets of LPC are shown below:

	December 31,	
	2018	2019
(In millions)		
<b>ASSETS</b>		
Current assets	\$ 87.0	\$ 94.6
Property and equipment, net	119.6	121.3
Total assets	<u>\$ 206.6</u>	<u>\$ 215.9</u>
<b>LIABILITIES AND PARTNERS' EQUITY</b>		
Other liabilities, primarily current	\$ 41.1	\$ 32.8
Partners' equity	165.5	183.1
Total liabilities and partners' equity	<u>\$ 206.6</u>	<u>\$ 215.9</u>

Summary income statements of LPC are shown below:

	Years ended December 31,		
	2017	2018	2019
(In millions)			
Revenues and other income:			
Kronos	\$ 157.5	\$ 165.9	\$ 176.2
Venator Investments	158.3	167.0	177.0
Total	<u>315.8</u>	<u>332.9</u>	<u>353.2</u>
Cost and expenses:			
Cost of sales	315.4	332.5	352.8
General and administrative	.4	.4	.4
Total	<u>315.8</u>	<u>332.9</u>	<u>353.2</u>
Net income	<u>\$ -</u>	<u>\$ -</u>	<u>\$ -</u>

**Leases.** We enter into various operating leases for manufacturing facilities, land and equipment. Beginning on January 1, 2019 with the adoption of ASU 2016-02, our operating leases are included in operating lease right-of-use assets, current operating lease liabilities and noncurrent operating lease liabilities in our Consolidated Balance Sheet. See Note 10. Our Chemicals Segment's principal German operating subsidiary leases the land under its Leverkusen TiO<sub>2</sub> production facility pursuant to a lease with Bayer AG that expires in 2050. The Leverkusen facility itself, which Kronos owns and which represents approximately one-third of our current TiO<sub>2</sub> production capacity, is located within Bayer's extensive manufacturing complex.

During 2019, our operating lease expense approximated \$8.2 million (which amount approximates the amount of cash paid during the period for our operating leases included in the determination of our cash flows from operating activities). During 2019, variable lease expense and short-term lease expense were not material. During 2019, we entered into new operating leases which resulted in the recognition of \$1.6 million in right-of-use operating lease assets and corresponding liabilities on our Consolidated Balance Sheet. At December 31, 2019, the weighted average remaining lease term of our operating leases was approximately 14 years and the weighted average discount rate associated with such leases was approximately 4.6%. Such average remaining lease term is weighted based on each arrangement's lease obligation, and such average discount rate is weighted based on each arrangement's total remaining lease payments.

At December 31, 2019, maturities of our operating lease liabilities were as follows:

Years ending December 31,	Amount (In millions)
2020	\$ 7.1
2021	6.3
2022	3.6
2023	2.4
2024	1.6
2025 and thereafter	19.4
Total remaining lease payments	40.4
Less imputed interest	12.0
Total lease obligations	28.4
Less current obligations	6.2
Long term lease obligations	\$ 22.2

With respect to our land lease associated with our Chemical Segment’s Leverkusen facility, we periodically establish the amount of rent for such land lease by agreement with Bayer for periods of at least two years at a time. The lease agreement provides for no formula, index or other mechanism to determine changes in the rent of such land lease; rather, any change in the rent is subject solely to periodic negotiation between Bayer and us. As such, we will account for any change in the rent associated with such lease subsequent to the January 1, 2019 adoption of the new ASU as a lease modification. Of the \$28.4 million total lease obligations at December 31, 2019, approximately \$7.0 million relates to our Leverkusen facility land lease.

At December 31, 2019, we have no significant lease commitments that have not yet commenced.

*Disclosures related to periods prior to adoption of the new lease standard*

Net rent expense approximated \$14 million in 2016, \$16 million in 2017 and \$15 million in 2018. At December 31, 2018, future minimum payments under non-cancellable operating leases having an initial or remaining term of more than one year were as follows:

Years ending December 31,	Amount (In millions)
2019	\$ 6.2
2020	5.0
2021	4.2
2022	3.2
2023	2.4
2024 and thereafter	21.5
Long term lease obligations	\$ 42.5

Approximately \$17 million of the \$42.5 million aggregate future minimum rental commitments at December 31, 2018 relates to our Chemicals Segment’s Leverkusen facility land lease discussed above. The minimum commitment amounts for such lease included in the table above for each year through the 2050 expiration of the lease are based upon the current annual rental rate as of December 31, 2018.

**Land held for development.** The land held for development relates to BMI and LandWell and is discussed in Note 1.

**Land contract receivables.** Land contract receivables classified as a noncurrent asset relate to our Real Estate Management and Development Segment. Such receivables relate to certain fees we collect from builders when the builder sells a home to a customer, as discussed in Note 1.

**Note receivables – OPA.** Under an Owner Participation Agreement (“OPA”) entered into by LandWell with the Redevelopment Agency of the City of Henderson, Nevada, if LandWell develops certain real property for commercial and residential purposes in a master planned community in Henderson, Nevada, the cost of certain public infrastructure may be reimbursed to us through tax increment. The maximum reimbursement under the OPA is \$209 million, and is subject to, among other things,

completing construction of approved qualifying public infrastructure, transferring title of such infrastructure to the City of Henderson, receiving approval from the Redevelopment Agency of the funds expended to be eligible for tax increment reimbursement and the existence of a sufficient property tax valuation base and property tax rates in order to generate tax increment reimbursement funds. We are entitled to receive 75% of the tax increment generated by the master planned community through 2036, subject to the qualifications and limitations indicated above. The OPA note receivables represent public infrastructure costs previously incurred for which the Redevelopment Agency has provided its approval for tax increment reimbursement but we have not yet received such reimbursement through tax increment receipts, and are evidenced by a promissory note issued to LandWell by the City of Henderson.

Prior to 2018, due to the significant uncertainty of the timing and amount of any of such potential tax increment reimbursements, we recognized any such tax increment reimbursements only when received. However, due to growth in the master planned community and the increase in tax increment funds to which we are entitled, we determined in the first quarter of 2018 the tax increment reimbursements expected to be collected in the future would at least be sufficient to support recognizing the promissory note payable issued by the City of Henderson to LandWell. During 2018, we recognized \$3.1 million of other income relating to the existing promissory note as of January 1, 2018. During 2019 we received approval for additional tax increment reimbursement of \$8.8 million (primarily in the second quarter), which was recognized as other income and is evidenced by a promissory note issued to LandWell by the City of Henderson. The note payable bears interest at 6% annually and the note expires in 2036. Any unpaid balances in 2036 are forfeited. See Note 13.

**Other.** We have certain related party transactions with LPC, as more fully described in Note 17.

The IBNR receivables relate to certain insurance liabilities, the risk of which we have reinsured with certain third party insurance carriers. We report the insurance liabilities related to these IBNR receivables which have been reinsured as part of noncurrent accrued insurance claims and expenses. Certain of our insurance liabilities are classified as current liabilities and the related IBNR receivables are classified with other current assets. See Notes 10 and 17.

#### Note 8—Goodwill:

We have assigned goodwill to each of our reporting units (as that term is defined in ASC Topic 350-20-20, *Goodwill*) which corresponds to our operating segments. All of our goodwill related to our Chemicals Segment is from our various step acquisitions of NL and Kronos which occurred prior to 2017, as goodwill was determined prior to the adoption of the equity transaction framework provisions of ASC Topic 810. Substantially all of the net goodwill related to the Component Products Segment was generated from CompX's acquisitions of certain business units and the step acquisitions of CompX. The Component Products Segment goodwill is assigned to the security products reporting unit within that operating segment.

	<u>Operating segment</u>		<u>Total</u>
	<u>Chemicals</u>	<u>Component Products</u> <u>(In millions)</u>	
Balance at December 31, 2017, 2018 and 2019	\$ 352.6	\$ 27.1	\$ 379.7

We test for goodwill impairment at the reporting unit level. In determining the estimated fair value of the reporting units, we use appropriate valuation techniques, such as discounted cash flows and, with respect to our Chemicals Segment, we consider quoted market prices, a Level 1 input, while discounted cash flows are a Level 3 input. We also consider control premiums when assessing fair value using quoted market prices. If the carrying amount of the reporting unit's net assets exceeds its fair value, an impairment charge is recorded for the amount by which such carrying amount exceeds the reporting unit's fair value (not to exceed the amount of goodwill recognized). We review goodwill for each of our reporting units for impairment during the third quarter of each year. Goodwill is also evaluated for impairment at other times whenever an event occurs or circumstances change that would more likely than not reduce the fair value of a reporting unit below its carrying value. If the fair value of an evaluated asset is less than its book value, the asset is written down to fair value.

In 2017, 2018 and 2019, no goodwill impairment was indicated as part of our annual impairment review of goodwill. As permitted by GAAP, during 2017, 2018 and 2019 we used the qualitative assessment of ASC 350-20-35 for our Component Products security products reporting unit's annual impairment test and determined it was not necessary to perform a quantitative goodwill impairment test. During 2016, we used the quantitative assessment of ASC 350-20-35 for security products reporting unit's annual impairment test using discounted cash flows to determine the estimated fair value of our security products reporting unit. Such discounted cash flows are a Level 3 input as defined by ASC 820-10-35.

Prior to 2017, we recorded an aggregate \$16.5 million goodwill impairment, mostly with respect to our Component Products

Segment. Our consolidated gross goodwill at December 31, 2019 is \$396.2 million.

**Note 9—Long-term debt:**

	December 31,	
	2018	2019
	(In millions)	
Valhi:		
Contran credit facility	\$ 314.3	\$ 313.0
Subsidiary debt:		
Kronos:		
Senior Notes	452.4	442.6
Tremont:		
Promissory note payable	9.4	2.0
BMI:		
Bank loan Western Alliance Bank	18.0	17.2
LandWell:		
Note payable to Western Alliance Business Trust	-	15.0
Note payable to the City of Henderson	2.1	1.6
Other	4.2	2.9
Total subsidiary debt	<u>486.1</u>	<u>481.3</u>
Total debt	800.4	794.3
Less current maturities	(2.9)	(4.9)
Total long-term debt	<u>\$ 797.5</u>	<u>\$ 789.4</u>

**Valhi—Contran credit facility**—We have an unsecured revolving credit facility with Contran which, as amended, provides for borrowings from Contran of up to \$360 million. The facility, as amended, bears interest at prime plus 1% (5.75% at December 31, 2019), and is due on demand, but in any event no earlier than December 31, 2021. The facility contains no financial covenants or other financial restrictions. Valhi pays an unused commitment fee quarterly to Contran on the available balance (except during periods during which Contran would be a net borrower from Valhi). The average interest rate on the credit facility for the year ended December 31, 2019 was 6.3%. During 2019 we made no borrowings and we repaid \$1.3 million under this facility and at December 31, 2019 an additional \$47.0 million was available for borrowings under this facility.

**Kronos—Senior Notes**—On September 13, 2017, Kronos International, Inc. (“KII”), Kronos’ wholly-owned subsidiary, issued €400 million aggregate principal amount of its 3.75% Senior Secured Notes due September 15, 2025 (the “Senior Notes”), at par value (\$477.6 million when issued). Kronos used \$338.6 million of the net proceeds of the Senior Notes to prepay in full the outstanding principal balance of its term loan (along with accrued and unpaid interest through the prepayment date) and \$21.0 million to repay the outstanding balance under its North American revolving credit facility. The remaining net proceeds of the Senior Notes are available for Kronos’ general corporate purposes. The Senior Notes:

- bear interest at 3.75% per annum, payable semi-annually on March 15 and September 15 of each year, beginning on March 15, 2018;
- have a maturity date of September 15, 2025. Prior to September 15, 2020, Kronos may redeem some or all of the Senior Notes at a price equal to 100% of the principal amount thereof, plus a “make-whole” premium (as defined in the indenture governing the Senior Notes). On or after September 15, 2020, Kronos may redeem the Senior Notes at redemption prices ranging from 102.813% of the principal amount, declining to 100% on or after September 15, 2023. In addition, on or before September 15, 2020, Kronos may redeem up to 40% of the Senior Notes with the net proceeds of certain public or private equity offerings at 103.75% of the principal amount. If Kronos experiences certain specified change of control events, it would be required to make an offer to purchase the Senior Notes at 101% of the principal amount. Kronos would also be required to make an offer to purchase a specified portion of the Senior Notes at par value in the event that it generates a certain amount of net proceeds from the sale of assets outside the ordinary course of business, and such net proceeds are not otherwise used for specified purposes within a specified time period;
- are fully and unconditionally guaranteed, jointly and severally, on a senior secured basis by Kronos Worldwide, Inc. and each of its direct and indirect domestic, wholly-owned subsidiaries;



- are collateralized by a first priority lien on (i) 100% of the common stock or other ownership interests of each existing and future direct domestic subsidiary of KII and the guarantors, and (ii) 65% of the voting common stock or other ownership interests and 100% of the non-voting common stock or other ownership interests of each foreign subsidiary that is directly owned by KII or any guarantor;
- contain a number of covenants and restrictions which, among other things, restrict Kronos' ability to incur or guarantee additional debt, incur liens, pay dividends or make other restricted payments, or merge or consolidate with, or sell or transfer substantially all of its assets to, another entity, and contain other provisions and restrictive covenants customary in lending transactions of this type (however, there are no ongoing financial maintenance covenants); and
- contain customary default provisions, including a default under any of Kronos' other indebtedness in excess of \$50.0 million.

The carrying value of the Senior Notes at December 31, 2019 is stated net of unamortized debt issuance costs of \$5.3 million (at December 31, 2018 the balance was \$6.3 million).

*Term loan* – During the first six months of 2017, Kronos made required quarterly term loan principal payments aggregating \$1.8 million on its prior term loan indebtedness. Concurrent with the issuance of its Senior Notes, in September 2017, Kronos voluntarily prepaid in full the outstanding \$338.6 million principal balance of such term loan (and such term loan facility was terminated). As a result of such prepayment, we recognized a loss on prepayment of debt aggregating \$7.1 million in the third quarter of 2017 consisting principally of the write-off of unamortized debt issuance costs and original issue discount associated with the term loan of \$2.7 million and \$.7 million, respectively, and \$3.3 million in expense related to the early termination of our interest rate swap contract discussed in Note 19. Funds for the aggregate prepayment were provided by the net proceeds from the Senior Notes discussed above.

*Revolving North American credit facility*—Kronos has a \$125 million revolving bank credit facility that, as amended, matures in January 2022. Borrowings under the revolving credit facility are available for Kronos' general corporate purposes. Available borrowings on this facility are based on formula-determined amounts of eligible trade receivables and inventories, as defined in the agreement, of certain of Kronos' North American subsidiaries less any outstanding letters of credit up to \$15 million issued under the facility (with revolving borrowings by Kronos' Canadian subsidiary limited to \$25 million). Any amounts outstanding under the revolving credit facility bear interest, at Kronos' option, at LIBOR plus a margin ranging from 1.5% to 2.0% or at the applicable base rate, as defined in the agreement, plus a margin ranging from .5% to 1.0%. The credit facility is collateralized by, among other things, a first priority lien on the borrowers' trade receivables and inventories. The facility contains a number of covenants and restrictions which, among other things, restricts the borrowers' ability to incur additional debt, incur liens, pay dividends or merge or consolidate with, or sell or transfer all or substantially all of their assets to, another entity, contains other provisions and restrictive covenants customary in lending transactions of this type and under certain conditions requires the maintenance of a specified financial covenant (fixed charge coverage ratio, as defined) to be at least 1.0 to 1.0.

Kronos had no borrowings or repayments under this facility in 2018 and 2019. At December 31, 2019, Kronos had approximately \$104.8 million available for borrowing under this revolving facility.

*Revolving European credit facility*—Kronos' operating subsidiaries in Germany, Belgium, Norway and Denmark have a €90 million secured revolving credit facility that, as amended, matures in September 2022. Outstanding borrowings bear interest at the Euro Interbank Offered Rate (EURIBOR) plus 1.60% per annum. The facility is collateralized by the accounts receivable and inventories of the borrowers, plus a limited pledge of all of the other assets of the Belgian borrower. The facility contains certain restrictive covenants that, among other things, restrict the ability of the borrowers to incur debt, incur liens, pay dividends or merge or consolidate with, or sell or transfer all or substantially all of the assets to, another entity, and requires the maintenance of certain financial ratios. In addition, the credit facility contains customary cross-default provisions with respect to other debt and obligations of the borrowers, KII and its other subsidiaries.

Kronos had no borrowing or repayments under this facility during 2018 and 2019 and at December 31, 2019, there were no outstanding borrowings under this facility. Kronos' European revolving credit facility requires the maintenance of certain financial ratios, and one of such requirements is based on the ratio of net debt to last twelve months earnings before income tax, interest, depreciation and amortization expense (EBITDA) of the borrowers. Based upon the borrowers' last twelve months EBITDA as of December 31, 2019 and the net debt to EBITDA financial test, the full €90 million (\$100.8 million) was available for borrowing at December 31, 2019.

*Other.* In 2013, and in conjunction with the acquisition of a controlling interest of our Real Estate Management and Development Segment, Tremont issued a \$19.1 million promissory note with the seller, Nevada Environmental Response Trust ("NERT"). The note bears interest at 3% per annum, with interest payable annually and all principal due in December 2023. The

promissory note is collateralized by the BMI and LandWell interests acquired as well as the real property acquired from NERT as part of the transaction. The note may be prepaid at any time without penalty. We must make mandatory prepayments on the note in specified amounts whenever we receive distributions from BMI or LandWell, or in the event we sell any of the real property acquired. We made principal prepayments of \$3.7 million during 2018 and \$7.4 million during 2019 under the terms of the note. We repaid an additional \$1.5 million during January 2020.

In February 2017, a wholly-owned subsidiary of BMI entered into a \$20.5 million loan agreement with Western Alliance Bank. The proceeds were used to refinance the \$8.5 million outstanding bank note payable to Meadows Bank and to finance improvements to BMI's water delivery system. The agreement requires semi-annual payments of principal and interest on June 1 and December 1 aggregating \$1.9 million annually beginning on June 1, 2017 through the maturity date in June 2032. The agreement bears interest at 5.34% and is collateralized by certain real property, including the water delivery system, and revenue streams under the City of Henderson water contract. The carrying value of the loan is stated net of debt issuance costs of \$.7 million at December 31, 2019.

Prior to 2017, LandWell entered into a \$3.9 million promissory note payable to the City of Henderson, Nevada. The note requires semi-annual principal payments of \$250,000 payable solely from cash received from certain specified revenue sources with any remaining unpaid balance due in October 2020, see Note 18. The loan bears interest at a 3% fixed rate. We made payments of \$.4 million during 2019 using receipts from the specified revenue sources. In January 2020, LandWell fully repaid this note using proceeds from the new loan discussed below.

In December 2019, LandWell entered into a \$15.0 million loan agreement with Western Alliance Business Trust. The proceeds will be used to finance certain public infrastructure costs incurred by LandWell under the OPA Landwell has with the Redevelopment Agency of the City of Henderson, Nevada as more fully discussed in Note 7, and to repay the City of Henderson note discussed above. The agreement requires semi-annual payments of principal and interest on April 15 and October 15 aggregating \$1.3 million annually beginning on April 15, 2020 through the maturity date in April 2036 and is payable from the tax increment reimbursement funds received under the OPA. The agreement bears interest at a fixed 4.76% rate and is collateralized by all tax increment reimbursement funds LandWell receives under the OPA.

***Aggregate maturities of long-term debt at December 31, 2019***

Aggregate maturities of debt at December 31, 2019 are presented in the table below.

<b>Years ending December 31,</b>	<b>Amount</b>
	<b>(In millions)</b>
Gross amounts due each year:	
2020	\$ 4.9
2021	315.4
2022	2.5
2023	4.0
2024	1.9
2025 and thereafter	471.6
Subtotal	800.3
Less amounts representing original issue discount and debt issuance costs	6.0
Total long-term debt	<u>\$ 794.3</u>

We are in compliance with all of our debt covenants at December 31, 2019.

**Note 10—Accounts payable and accrued liabilities:**

	December 31,	
	2018	2019
(In millions)		
Accounts payable:		
Kronos	\$ 103.2	\$ 137.2
CompX	3.2	2.5
BMI/LandWell	2.9	3.7
NL	1.6	.9
Other	.6	.4
Total	<u>\$ 111.5</u>	<u>\$ 144.7</u>
Current accrued liabilities:		
Employee benefits	\$ 37.5	\$ 30.6
Operating lease liabilities	-	6.2
Accrued sales discounts and rebates	29.7	33.7
Deferred income	28.3	10.3
Environmental remediation and related costs	6.5	4.5
Interest	5.2	5.2
Other	33.6	40.0
Total	<u>\$ 140.8</u>	<u>\$ 130.5</u>
Noncurrent accrued liabilities:		
Other postretirement benefits	\$ 10.3	\$ 10.5
Operating lease liabilities	-	22.2
Reserve for uncertain tax positions	19.1	13.6
Deferred income	15.8	47.4
Employee benefits	7.1	6.0
Insurance claims and expenses	8.1	11.0
Deferred payment obligation	9.6	9.9
Accrued development costs	7.5	8.3
Other	9.9	8.2
Total	<u>\$ 87.4</u>	<u>\$ 137.1</u>

The risks associated with certain of our accrued insurance claims and expenses have been reinsured, and the related IBNR receivables are recognized as noncurrent assets to the extent the related liability is classified as a noncurrent liability. See Note 7. Our reserve for uncertain tax positions is discussed in Note 14.

In 2013 and in conjunction with the acquisition of a controlling interest of our Real Estate Management and Development Segment, we issued a face value \$11.1 million deferred payment obligation owed to NERT that bears interest at 3% per annum, commencing in December 2023, and is collateralized by the BMI and LandWell interests acquired. The deferred payment obligation has no specified maturity date. We are required to make repayments on the deferred payment obligation, in specified amounts, whenever we receive distributions from BMI and LandWell, and we may make voluntary repayments on the deferred payment obligation at any time, in each case without any penalty, but in any case only after our promissory note payable to NERT (discussed in Note 9) has been repaid in full. For financial reporting purposes, the obligation was recorded at its acquisition date present value using a 3% discount rate from December 2023 (when it becomes interest bearing at 3%).

**Note 11—Defined contribution and defined benefit retirement:**

**Defined contribution plans.** Certain of our subsidiaries maintain various defined contribution pension plans for our employees worldwide. Defined contribution plan expense approximated \$5.5 million in 2017, \$6.6 million in 2018 and \$6.5 million in 2019.

**Defined benefit plans.** Kronos and NL sponsor various defined benefit pension plans worldwide. The benefits under our defined benefit plans are based upon years of service and employee compensation. Our funding policy is to contribute annually the minimum amount required under ERISA (or equivalent foreign) regulations plus additional amounts as we deem appropriate. We recognize an asset or liability for the over or under funded status of each of our individual defined benefit pension plans on our Consolidated Balance Sheets. Changes in the funded status of these plans are recognized either in net income, to the extent they are reflected in periodic benefit cost, or through other comprehensive income (loss).

We expect to contribute the equivalent of approximately \$19 million to all of our defined benefit pension plans during 2020. Benefit payments to plan participants out of plan assets are expected to be the equivalent of:

2020	\$ 26.5 million
2021	27.3 million
2022	28.3 million
2023	28.2 million
2024	30.0 million
Next 5 years	167.8 million

The funded status of our U.S. defined benefit pension plans is presented in the table below.

	<u>Years ended December 31,</u>	
	<u>2018</u>	<u>2019</u>
	(In millions)	
Change in projected benefit obligations ("PBO"):		
Balance at beginning of the year	\$ 63.0	\$ 57.6
Interest cost	2.2	2.3
Actuarial losses (gains)	(3.4)	4.9
Benefits paid	(4.2)	(4.2)
Balance at end of the year	<u>\$ 57.6</u>	<u>\$ 60.6</u>
Change in plan assets:		
Fair value at beginning of the year	\$ 46.5	\$ 43.2
Actual return on plan assets	(2.5)	5.5
Employer contributions	3.4	3.9
Benefits paid	(4.2)	(4.2)
Fair value at end of the year	<u>\$ 43.2</u>	<u>\$ 48.4</u>
Funded status	<u>\$ (14.4)</u>	<u>\$ (12.2)</u>
Amounts recognized in the Consolidated Balance Sheets:		
Accrued pension costs:		
Current	\$ (.2)	\$ (.3)
Noncurrent	(14.2)	(11.9)
Total	(14.4)	(12.2)
Accumulated other comprehensive loss — actuarial loss	39.0	38.5
Total	<u>\$ 24.6</u>	<u>\$ 26.3</u>
Accumulated benefit obligations ("ABO")	<u>\$ 57.6</u>	<u>\$ 60.6</u>

The components of our net periodic defined benefit pension benefit cost for U.S. plans are presented in the table below. The amounts shown below for the amortization of unrecognized actuarial losses for 2017, 2018 and 2019 were recognized as components of our accumulated other comprehensive income (loss) at December 31, 2016, 2017 and 2018, respectively, net of deferred income taxes and noncontrolling interest.

	<b>Years ended December 31,</b>		
	<b>2017</b>	<b>2018</b>	<b>2019</b>
	<b>(In millions)</b>		
Net periodic pension benefit cost (credit) for U.S. plans			
Interest cost	\$ 2.5	\$ 2.2	\$ 2.3
Expected return on plan assets	(3.3)	(3.4)	(2.3)
Amortization of unrecognized net actuarial loss	2.0	2.0	2.2
Total	<u>\$ 1.2</u>	<u>\$ .8</u>	<u>\$ 2.2</u>

Information concerning our U.S. defined benefit pension plans (for which the ABO of all of the plans exceeds the fair value of plan assets as of the indicated date) is presented in the table below.

	<b>December 31,</b>	
	<b>2018</b>	<b>2019</b>
	<b>(In millions)</b>	
Plans for which the ABO exceeds plan assets:		
Projected benefit obligations	\$ 57.6	\$ 60.6
Accumulated benefit obligations	57.6	60.6
Fair value of plan assets	43.2	48.4

The discount rate assumptions used in determining the actuarial present value of the benefit obligation for our U.S. defined benefit pension plans as of December 31, 2018 and 2019 are 4.1% and 3.1%, respectively. The impact of assumed increases in future compensation levels does not have an effect on the benefit obligation as the plans are frozen with regards to compensation.

The weighted-average rate assumptions used in determining the net periodic pension cost for our U.S. defined benefit pension plans for 2017, 2018 and 2019 are presented in the table below. The impact of assumed increases in future compensation levels does not have an effect on the periodic pension cost as the plans are frozen with regards to compensation.

	<b>Years ended December 31,</b>		
	<b>2017</b>	<b>2018</b>	<b>2019</b>
Discount rate	3.9 %	3.5 %	4.1 %
Long-term return on plan assets	7.5 %	7.5 %	5.5 %

Variances from actuarially assumed rates will result in increases or decreases in accumulated pension obligations, pension expense and funding requirements in future periods.

The funded status of our foreign defined benefit pension plans is presented in the table below.

	<b>Years ended December 31,</b>	
	<b>2018</b>	<b>2019</b>
	<b>(In millions)</b>	
Change in PBO:		
Balance at beginning of the year	\$ 691.2	\$ 667.2
Service cost	11.6	12.8
Interest cost	13.8	13.5
Participants' contributions	1.5	1.6
Actuarial loss	5.8	82.0
Plan settlement	-	(1.0)
Change in currency exchange rates	(33.9)	(6.6)
Benefits paid	(22.8)	\$ (23.1)
Balance at end of the year	<u>\$ 667.2</u>	<u>\$ 746.4</u>
Change in plan assets:		
Fair value at beginning of the year	\$ 445.2	\$ 410.7
Actual return on plan assets	(6.1)	47.0
Employer contributions	16.5	15.5
Participants' contributions	1.5	1.6
Change in currency exchange rates	(23.6)	(1.7)
Benefits paid	(22.8)	(23.1)
Fair value at end of the year	<u>\$ 410.7</u>	<u>\$ 450.0</u>
Funded status	<u>\$ (256.5)</u>	<u>\$ (296.4)</u>
Amounts recognized in the Consolidated Balance Sheets:		
Pension asset	\$ 2.7	\$ 7.4
Accrued pension costs:		
Noncurrent	(259.2)	(303.8)
Total	(256.5)	(296.4)
Accumulated other comprehensive loss:		
Actuarial loss	254.1	286.8
Prior service cost	1.2	1.0
Total	255.3	287.8
Total	<u>\$ (1.2)</u>	<u>\$ (8.6)</u>
ABO	<u>\$ 642.2</u>	<u>\$ 720.3</u>

The components of our net periodic pension benefit cost for our foreign plans are presented in the table below. The amounts shown below for the amortization of unrecognized prior service cost and actuarial losses for 2017, 2018 and 2019 were recognized as components of our accumulated other comprehensive income (loss) at December 31, 2016, 2017 and 2018, respectively, net of deferred income taxes and noncontrolling interest.

	<b>Years ended December 31,</b>		
	<b>2017</b>	<b>2018</b>	<b>2019</b>
	<b>(In millions)</b>		
Net periodic pension cost for foreign plans:			
Service cost	\$ 11.4	\$ 11.6	\$ 12.8
Interest cost	13.4	13.8	13.5
Settlement loss	.1	-	-
Expected return on plan assets	(9.7)	(12.7)	(11.9)
Amortization of unrecognized:			
Prior service cost	.3	.2	.2
Net actuarial loss	13.2	13.2	12.8
Total	<u>\$ 28.7</u>	<u>\$ 26.1</u>	<u>\$ 27.4</u>

Information concerning certain of our non-U.S. defined benefit pension plans (for which the ABO exceeds the fair value of plan assets as of the indicated date) is presented in the table below.

	<b>December 31,</b>	
	<b>2018</b>	<b>2019</b>
	<b>(In millions)</b>	
Plans for which the ABO exceeds plan assets:		
Projected benefit obligations	\$ 605.0	\$ <b>685.4</b>
Accumulated benefit obligations	585.0	<b>663.3</b>
Fair value of plan assets	346.3	<b>381.7</b>

The key actuarial assumptions used to determine our foreign benefit obligations as of December 31, 2018 and 2019 are as follows:

	<b>December 31,</b>	
	<b>2018</b>	<b>2019</b>
Discount rate	2.1 %	<b>1.4 %</b>
Increase in future compensation levels	2.6 %	<b>2.6 %</b>

A summary of our key actuarial assumptions used to determine foreign net periodic benefit cost for 2017, 2018 and 2019 are as follows:

	<b>Years ended December 31,</b>		
	<b>2017</b>	<b>2018</b>	<b>2019</b>
Discount rate	2.1 %	2.1 %	<b>2.1 %</b>
Increase in future compensation levels	2.6 %	2.6 %	<b>2.6 %</b>
Long-term return on plan assets	2.5 %	3.0 %	<b>2.9 %</b>

Variances from actuarially assumed rates will result in increases or decreases in accumulated pension obligations, pension expense and funding requirements in future periods.

The amounts shown for all of our defined benefit plans for unrecognized actuarial losses and prior service cost at December 31, 2018 and 2019 have not been recognized as components of our periodic defined benefit pension cost as of those dates. These amounts will be recognized as components of our periodic defined benefit cost in future years. These amounts, net of deferred income taxes and noncontrolling interest, are recognized in our accumulated other comprehensive income (loss) at December 31, 2018 and 2019. We expect approximately \$19.3 million and \$.2 million of the unrecognized actuarial losses and prior service cost, respectively, will be recognized as components of our periodic defined benefit pension cost in 2020. The table below details the changes in other comprehensive income (loss) during 2017, 2018 and 2019.

	<b>Years ended December 31,</b>		
	<b>2017</b>	<b>2018</b>	<b>2019</b>
	<b>(In millions)</b>		
Changes in plan assets and benefit obligations recognized in other comprehensive income (loss):			
Net actuarial gain (loss)	\$ 4.0	\$ (27.0)	\$ <b>(47.2)</b>
Amortization of unrecognized:			
Prior service cost	.3	.2	<b>.2</b>
Net actuarial losses	15.2	15.2	<b>15.0</b>
Total	<u>\$ 19.5</u>	<u>\$ (11.6)</u>	<u>\$ <b>(32.0)</b></u>

At December 31, 2017, substantially all of the assets attributable to our U.S. plan were invested in the Combined Master Retirement Trust (CMRT), a collective investment trust sponsored by Contran to permit the collective investment by certain master trusts that fund certain employee benefit plans sponsored by Contran and certain of its affiliates, including us. For 2017 and 2018, the long-term rate of return assumption for our U.S. plan assets was 7.5%, based on the long-term asset mix of the assets of the CMRT and the expected long-term rates of return for such asset components as well as advice from Contran's actuaries. During 2018, Contran and the other employer-sponsors (including us) implemented a restructuring of the CMRT, in which a substantial part of each plan's units in the CMRT were redeemed in exchange for a pro-rata portion of a substantial part of the CMRT's investments. Following such restructuring, the plans held directly in the aggregate the investments previously held directly by the CMRT which had been exchanged for CMRT units as part of the restructuring. During 2019, the remaining investments of the CMRT allocable to our U.S. plan were transferred and are held as direct investments of our U.S. plan at December 31, 2019. Such restructuring was implemented in part so each plan could more easily align the composition of its plan asset portfolio with the plan's benefit obligations.

In determining the expected long-term rate of return on plan asset assumptions, we consider the long-term asset mix (e.g. equity vs. fixed income) for the assets for each of our plans and the expected long-term rates of return for such asset components. In addition, we receive third-party advice about appropriate long-term rates of return. Such assumed asset mixes are summarized below:

- In Germany, the composition of our plan assets is established to satisfy the requirements of the German insurance commissioner. Our German pension plan assets represent an investment in a large collective investment fund established and maintained by Bayer AG in which several pension plans, including our German pension plans and Bayer's pension plans, have invested. Our plan assets represent a very nominal portion of the total collective investment fund maintained by Bayer. These plan assets are a Level 3 in the fair value hierarchy because there is not an active market that approximates the value of our investment in the Bayer investment fund. We estimate the fair value of the Bayer plan assets based on periodic reports we receive from the managers of the Bayer fund and using a model we developed with assistance from our third-party actuary that uses estimated asset allocations and correlates such allocation to similar asset mixes in fund indexes quoted on an active market. We periodically evaluate the results of our valuation model against actual returns in the Bayer fund and adjust the model as needed. The Bayer fund periodic reports are subject to audit by the German pension regulator.
- In Canada, we currently have a plan asset target allocation of 20% to 30% to equity securities and 70% to 80% to fixed income securities. We expect the long-term rate of return for such investments to approximate the applicable equity or fixed income index. The Canadian assets are Level 1 inputs because they are traded in active markets.
- In Norway, we currently have a plan asset target allocation of 11% to equity securities, 67% to fixed income securities, 12% to real estate and the remainder primarily to other investments and liquid investments such as money markets. The expected long-term rate of return for such investments is approximately 7%, 3%, 5% and 8%, respectively. The majority of Norwegian plan assets are Level 1 inputs because they are traded in active markets; however approximately 14% of our Norwegian plan assets are invested in real estate and other investments not actively traded and are therefore a Level 3 input.
- In the U.S. we currently have a plan asset target allocation of 36% to equity securities, 49% to fixed income securities, and the remainder is allocated to multi-asset strategies. The expected long-term rate of return for such investments is approximately 9%, 4% and 3%, respectively (before plan administrative expenses). The majority of U.S. plan assets are Level 1 inputs because they are traded in active markets, and approximately 30% of our U.S. plan assets are invested in funds that are valued at net asset value (NAV) and not subject to classification in the fair value hierarchy
- We also have plan assets in Belgium and the United Kingdom. The Belgian plan assets are invested in certain individualized fixed income insurance contracts for the benefit of each plan participant as required by the local regulators and are therefore a Level 3 input. The United Kingdom plan assets consist of marketable securities which are Level 1 inputs because they trade in active markets.

We regularly review our actual asset allocation for each plan, and will periodically rebalance the investments in each plan to more accurately reflect the targeted allocation and/or maximize the overall long-term return when considered appropriate.



The composition of our pension plan assets by asset category and fair value level at December 31, 2018 and 2019 is shown in the tables below.

<b>Fair Value Measurements at December 31, 2018</b>					
	<b>Total</b>	<b>Quoted prices in active markets (Level 1)</b>	<b>Significant other observable inputs (Level 2)</b>	<b>Significant unobservable inputs (Level 3)</b>	<b>Assets measured at NAV</b>
	<b>(In millions)</b>				
Germany	\$ 241.5	\$ -	\$ -	\$ 241.5	\$ -
Canada:					
Local currency equities	6.5	6.5	-	-	-
Non local currency equities	13.3	13.3	-	-	-
Local currency fixed income	74.1	74.1	-	-	-
Cash and other	.5	.5	-	-	-
Norway:					
Local currency equities	1.7	1.7	-	-	-
Non local currency equities	4.3	4.3	-	-	-
Local currency fixed income	20.4	14.9	5.5	-	-
Non local currency fixed income	6.1	6.1	-	-	-
Real estate	4.5	-	-	4.5	-
Cash and other	13.5	12.7	-	.8	-
U.S.					
Equities	16.3	4.9	-	-	11.4
Fixed income	19.9	19.9	-	-	-
Cash and other	4.7	3.4	-	-	1.3
CMRT	2.3	-	-	2.3	-
Other	24.4	13.9	-	10.5	-
Total	<u>\$ 454.0</u>	<u>\$ 176.2</u>	<u>\$ 5.5</u>	<u>\$ 259.6</u>	<u>\$ 12.7</u>

**Fair Value Measurements at December 31, 2019**

	<b>Total</b>	<b>Quoted prices in active markets (Level 1)</b>	<b>Significant other observable inputs (Level 2)</b>	<b>Significant unobservable inputs (Level 3)</b>	<b>Assets measured at NAV</b>
	<b>(In millions)</b>				
Germany	\$ 264.5	\$ -	\$ -	\$ 264.5	\$ -
Canada:					
Local currency equities	8.3	8.3	-	-	-
Non local currency equities	16.3	16.3	-	-	-
Local currency fixed income	80.9	80.9	-	-	-
Cash and other	.6	.6	-	-	-
Norway:					
Local currency equities	1.6	1.6	-	-	-
Non local currency equities	4.2	4.2	-	-	-
Local currency fixed income	22.8	14.1	8.7	-	-
Non local currency fixed income	8.3	8.3	-	-	-
Real estate	6.6	-	-	6.6	-
Cash and other	8.2	7.4	-	.8	-
U.S.					
Equities	19.2	5.4	-	.6	13.2
Fixed income	23.3	23.3	-	-	-
Cash and other	6.0	4.6	-	-	1.4
Other	27.6	16.6	-	11.0	-
<b>Total</b>	<b>\$ 498.4</b>	<b>\$ 191.6</b>	<b>\$ 8.7</b>	<b>\$ 283.5</b>	<b>\$ 14.6</b>

A rollforward of the change in fair value of Level 3 assets follows.

	<b>Years ended December 31,</b>	
	<b>2018</b>	<b>2019</b>
	<b>(In millions)</b>	
Fair value at beginning of year	\$ 273.6	\$ 259.6
Gain (loss) on assets held at end of year	(4.6)	30.2
Loss on assets sold during the year	-	(1.1)
Assets purchased	14.1	16.0
Assets sold	(14.5)	(14.9)
Transfer in	2.3	-
Currency exchange rate fluctuations	(11.3)	(6.3)
Fair value at end of year	<b>\$ 259.6</b>	<b>\$ 283.5</b>

**Note 12 –Disaggregation of Sales**

*Disaggregation of sales*—The following table disaggregates the net sales of our Chemicals Segment by place of manufacture (point of origin) and the location of the customer (point of destination), which are the categories that depict how the nature, amount, timing and uncertainty of revenue and cash flows are affected by economic factors.

	<b>Years ended December 31,</b>		
	<b>2017</b>	<b>2018</b>	<b>2019</b>
	<b>(In millions)</b>		
Net sales - point of origin:			
Germany	\$ 918.6	\$ 886.1	\$ 883.6
United States	841.8	839.4	998.5
Canada	309.2	307.2	328.7
Belgium	279.9	272.2	270.7
Norway	216.4	209.6	192.2
Eliminations	(836.9)	(852.6)	(942.5)
Total	<u>\$ 1,729.0</u>	<u>\$ 1,661.9</u>	<u>\$ 1,731.2</u>
Net sales - point of destination:			
Europe	\$ 898.8	\$ 817.2	\$ 823.5
North America	519.4	542.0	575.6
Other	310.8	302.7	332.1
Total	<u>\$ 1,729.0</u>	<u>\$ 1,661.9</u>	<u>\$ 1,731.2</u>

The following table disaggregates the net sales of our Component Products and Real Estate Management and Development Segments by major product line, which are the categories that depict how the nature, amount, timing and uncertainty of revenue and cash flows for these segments are affected by economic factors.

	<b>Years ended December 31,</b>		
	<b>2017</b>	<b>2018</b>	<b>2019</b>
	<b>(In millions)</b>		
Component Products:			
Net sales:			
Security products	\$ 96.6	\$ 98.4	\$ 99.3
Marine components	15.4	19.8	24.9
Total	<u>\$ 112.0</u>	<u>\$ 118.2</u>	<u>\$ 124.2</u>
Real Estate Management and Development:			
Net sales:			
Land sales	\$ 30.2	\$ 32.3	\$ 33.5
Water delivery	6.0	5.6	6.8
Utility and other	2.2	2.1	1.8
Total	<u>\$ 38.4</u>	<u>\$ 40.0</u>	<u>\$ 42.1</u>

**Note 13—Other income, net:**

	Years ended December 31,		
	2017	2018	2019
	(In millions)		
Securities earnings:			
Dividends and interest	\$ 29.4	\$ 26.1	\$ 10.9
Securities transactions, net	.1	12.4	.3
Total	<u>29.5</u>	<u>38.5</u>	<u>11.2</u>
Gain on land sales	-	12.5	4.4
Gain on sale of business	-	-	3.0
Insurance recoveries	.4	1.3	7.7
Currency transactions, net	(7.5)	10.1	2.0
Disposal of property and equipment, net	(.5)	(.3)	(.3)
Infrastructure reimbursement	1.0	4.3	9.2
Other, net	2.3	2.8	3.7
Total	<u>\$ 25.2</u>	<u>\$ 69.2</u>	<u>\$ 40.9</u>

Dividends and interest income includes distributions from The Amalgamated Sugar Company LLC of \$25.4 million in 2017 and \$16.9 million in 2018. Securities transactions, net in 2018 includes a \$12.5 million gain on the sale of our investment in The Amalgamated Sugar Company LLC. See Note 6.

Infrastructure reimbursements related to the OPA are discussed in Note 7.

Insurance recoveries relate primarily to amounts NL received from certain of its former insurance carriers, and relate principally to the recovery of prior lead pigment and asbestos litigation defense costs. NL has agreements with certain of its former insurance carriers pursuant to which the carriers reimburse it for a portion of its future lead pigment litigation defense costs, and one such carrier reimburses NL for a portion of its future asbestos litigation defense costs. We are not able to determine how much NL will ultimately recover from these carriers for defense costs incurred, because of certain issues that arise regarding which defense costs qualify for reimbursement. While NL continues to seek additional insurance recoveries for lead pigment and asbestos litigation matters, we do not know the extent to which it will be successful in obtaining additional reimbursement for either defense costs or indemnity. In 2019, NL recognized \$5.1 million in insurance recoveries which represented recovery of past and future litigation defense costs primarily related to a single insurance recovery settlement. In the fourth quarter of 2019, Kronos recognized a gain of \$2.6 million related to an insurance settlement for a property damage claim.

In the first quarter of 2018 we sold two parcels of land not used in our operating activities. We sold the first parcel for net proceeds of \$18.9 million, and recognized a pre-tax gain on the sale of \$11.9 million. We were required under our debt agreement with NERT to use a portion of the net proceeds received for the property to pay down our note balance and accordingly we made \$2.2 million in principal payments on our debt, see Note 9. In addition, in 2018 NL sold excess property with a nominal book value for proceeds of \$.6 million. In the third quarter of 2019, NL sold excess property for net proceeds of \$4.6 million and recognized a pre-tax gain of \$4.4 million. In the fourth quarter of 2019, NL sold its insurance and risk management business for proceeds of \$3.25 million and recognized a pre-tax gain of \$3.0 million on the sale.

**Note 14—Income taxes:**

	Years ended December 31,		
	2017	2018	2019
	(In millions)		
Pre-tax income (loss):			
United States	\$ 26.7	\$ (22.5)	\$ 23.5
Non-U.S. subsidiaries	265.1	258.7	81.2
Total	<u>\$ 291.8</u>	<u>\$ 236.2</u>	<u>\$ 104.7</u>
Expected tax expense at U.S. federal statutory income tax rate of 35% in 2017 and 21% in 2018 and 2019	\$ 102.1	\$ 49.6	\$ 22.0
Non-U.S. tax rates	(13.1)	20.8	5.2
Incremental net tax expense (benefit) on earnings and losses of U.S. and non-U.S. tax group companies	14.8	(167.8)	(4.5)
Valuation allowance	(205.4)	-	4.5
Transition tax	76.2	(2.1)	-
Global intangible low-tax income, net	-	4.0	1.8
Tax rate changes	(77.1)	58.8	4.7
U.S. state income taxes, net	3.5	.6	(.3)
Adjustment to the reserve for uncertain tax positions, net	(18.2)	4.1	(5.1)
Nondeductible expenses	2.2	3.0	1.5
Canada - Germany APA	-	(1.4)	-
Refund of prior tax payments, net	-	-	(2.1)
Domestic production activities deduction	(3.8)	-	-
Other, net	(1.2)	(.3)	(1.2)
Income tax expense (benefit)	<u>\$ (120.0)</u>	<u>\$ (30.7)</u>	<u>\$ 26.5</u>
Components of income tax expense (benefit):			
Currently payable:			
U.S. federal and state	\$ 87.3	\$ 34.1	\$ 4.3
Non-U.S.	38.5	51.1	22.0
Total	<u>125.8</u>	<u>85.2</u>	<u>26.3</u>
Deferred income taxes (benefit):			
U.S. federal and state	(96.9)	(145.5)	(4.1)
Non-U.S.	(148.9)	29.6	4.3
Total	<u>(245.8)</u>	<u>(115.9)</u>	<u>.2</u>
Income tax expense (benefit)	<u>\$ (120.0)</u>	<u>\$ (30.7)</u>	<u>\$ 26.5</u>
Comprehensive provision for income taxes (benefit) allocable to:			
Income from continuing operations	\$ (120.0)	\$ (30.7)	\$ 26.5
Discontinued operations	(67.1)	23.7	-
Retained earnings-change in accounting principle	-	1.1	-
Other comprehensive income (loss):			
Marketable securities	2.8	-	-
Currency translation	31.1	(4.2)	(.2)
Pension plans	8.6	(4.7)	(15.6)
Other	(.6)	(.4)	(.5)
Interest rate swap	1.6	-	-
Total	<u>\$ (143.6)</u>	<u>\$ (15.2)</u>	<u>\$ 10.2</u>

The amount shown in the above table of our income tax rate reconciliation for non-U.S. tax rates represents the result determined by multiplying the pre-tax earnings or losses of each of our non-U.S. subsidiaries by the difference between the applicable statutory income tax rate for each non-U.S. jurisdiction and the U.S. federal statutory tax rate. The amount shown on such table for incremental net tax expense (benefit) on earnings and losses on non-U.S. and non-tax group companies includes, as applicable, (i) deferred income taxes (or deferred income tax benefits) associated with the current-year change in the aggregate amount of

undistributed earnings of our Chemicals Segment's Canadian subsidiary and, beginning in 2018, deferred income taxes (or deferred income tax benefits) associated with the current year earnings of all our Chemicals Segment's non-U.S. subsidiaries (undistributed earnings of our Chemicals Segment's European subsidiaries were subject to a permanent reinvestment plan until December 31, 2017), (ii) current U.S. income taxes (or current income tax benefit), including U.S. personal holding company tax, as applicable, attributable to current-year income (losses) of one of Kronos' non-U.S. subsidiaries, which subsidiary is treated as a dual resident for U.S. income tax purposes, to the extent the current-year income (losses) of such subsidiary is subject to U.S. income tax under the U.S. dual-resident provisions of the Internal Revenue Code, (iii) deferred income taxes associated with our direct investment in Kronos and (iv) current and deferred income taxes associated with distributions and earnings from our investment in LandWell and BMI.

The components of the net deferred tax liability at December 31, 2018 and 2019 are summarized below.

	<b>December 31,</b>			
	<b>2018</b>		<b>2019</b>	
	<u>Assets</u>	<u>Liabilities</u>	<u>Assets</u>	<u>Liabilities</u>
	(In millions)			
Tax effect of temporary differences related to:				
Inventories	\$ 4.7	\$ (3.3)	\$ 6.2	\$ (2.5)
Marketable securities	-	(.2)	-	(.3)
Property and equipment	-	(69.0)	5.9	(67.9)
Accrued OPEB costs	2.8	-	2.8	-
Accrued pension costs	75.5	-	80.6	-
Accrued environmental liabilities	35.8	-	33.8	-
Other deductible differences	10.3	-	8.3	-
Other taxable differences	-	(13.2)	-	(13.4)
Investments in subsidiaries and affiliates	2.6	(58.8)	2.6	(54.4)
Tax on unremitted earnings of non-U.S. subsidiaries	-	(11.3)	-	(10.8)
Tax loss and tax credit carryforwards	93.9	-	91.2	-
Valuation allowance	(10.0)	-	(14.2)	-
Adjusted gross deferred tax assets (liabilities)	<u>215.6</u>	<u>(155.8)</u>	<u>217.2</u>	<u>(149.3)</u>
Netting of items by tax jurisdiction	(114.6)	(114.6)	(111.2)	(111.2)
Net noncurrent deferred tax asset (liability)	<u>\$ 101.0</u>	<u>\$ (41.2)</u>	<u>\$ 106.0</u>	<u>\$ (38.1)</u>

Tax authorities may in the future examine certain of our U.S. and non-U.S. tax returns and have or may propose tax deficiencies, including penalties and interest. Because of the inherent uncertainties involved in settlement initiatives and court and tax proceedings, we cannot guarantee that these tax matters, if any, will be resolved in our favor, and therefore our potential exposure, if any, is also uncertain.

Our Chemicals Segment has substantial net operating loss (NOL) carryforwards in Germany (the equivalent of \$501 million for German corporate purposes at December 31, 2019) and in Belgium (the equivalent of \$8 million for Belgian corporate tax purposes at December 31, 2019), all of which have an indefinite carryforward period. As a result, we have net deferred income tax assets with respect to these two jurisdictions, primarily related to these NOL carryforwards. The German corporate tax is similar to the U.S. federal income tax, and the German trade tax is similar to the U.S. state income tax (our Chemicals Segment's German trade tax NOLs were fully utilized as of December 31, 2018). Prior to 2017, we concluded that we were required to recognize a non-cash deferred income tax asset valuation allowance under the more-likely-than-not recognition criteria with respect to our Chemicals Segment's German and Belgian net deferred income tax assets. At December 31, 2016 such valuation allowance aggregated \$173 million (\$153 million with respect to Germany and \$20 million with respect to Belgium). During the first six months of 2017, we recognized an aggregate non-cash deferred income tax benefit of \$12.7 million as a result of a net decrease in such deferred income tax asset valuation allowance, due to utilizing a portion of both the German and Belgian NOL during the period. At June 30, 2017, our Chemicals Segment concluded we had sufficient positive evidence under the more-likely-than-not recognition criteria to support reversal of the entire valuation allowance related to our German and Belgian operations. In accordance with the ASC 740-270 guidance regarding accounting for income taxes at interim dates, the amount of the valuation allowance reversed at June 30, 2017 (\$149.9 million, of which \$141.9 million related to Germany and \$8.0 million related to Belgium) was associated with our Chemicals Segment's change in judgment at that date regarding the realizability of the related deferred income tax asset as it relates to future years (i.e. 2018 and after). A change in judgment regarding the realizability of deferred tax assets as it relates to the current year is considered in determining the estimated annual effective tax rate for the year and is recognized throughout the year, including interim periods subsequent to the date of the change in judgment. Accordingly, our income tax benefit in calendar year 2017 included an

aggregate non-cash deferred income tax benefit of \$186.7 million associated with the reversal of the German and Belgian valuation allowance, comprised of \$12.7 million recognized in the first half of 2017 (noted above) associated with the utilization of a portion of both the German and Belgian NOLs during such period, \$149.9 million related to the portion of the valuation allowance reversed as of June 30, 2017 and \$24.1 million recognized in the second half of 2017 associated with the utilization of a portion of both the German and Belgian NOLs during such period. Our deferred income tax asset valuation allowance increased \$13.7 million in 2017 as a result of changes in currency exchange rates, which increase was recognized as part of other comprehensive income (loss).

On December 22, 2017, the 2017 Tax Act was enacted into law. This new tax legislation, among other changes, (i) reduced the U.S. Federal corporate income tax rate from 35% to 21% effective January 1, 2018; (ii) implemented a territorial tax system and imposed a one-time repatriation tax (Transition Tax) on the deemed repatriation of the post-1986 undistributed earnings of non-U.S. subsidiaries accumulated up through December 31, 2017, regardless of whether such earnings are repatriated; (iii) eliminated U.S. tax on future non-U.S. earnings (subject to certain exceptions); (iv) eliminated the domestic production activities deduction beginning in 2018; (v) eliminated the net operating loss carryback and provides for an indefinite carryforward period subject to an 80% annual usage limitation; (vi) allows for the expensing of certain capital expenditures; (vii) imposed a tax on global intangible low-tax income (GILTI) beginning in 2018; (viii) imposed a base erosion anti-abuse tax (BEAT) beginning in 2018; and (ix) amended the rules limiting the deduction for business interest expense beginning in 2018. Following the enactment of the 2017 Tax Act, the Securities and Exchange Commission issued Staff Accounting Bulletin (SAB) 118 to provide guidance on the accounting and reporting impacts of the 2017 Tax Act. SAB 118 states that companies should account for changes related to the 2017 Tax Act in the period of enactment if all information is available and the accounting can be completed. In situations where companies do not have enough information to complete the accounting in the period of enactment, a company must either 1) record an estimated provisional amount if the impact of the change can be reasonably estimated; or 2) continue to apply the accounting guidance that was in effect immediately prior to the 2017 Tax Act if the impact of the change cannot be reasonably estimated. If estimated provisional amounts are recorded, SAB 118 provides a measurement period of no longer than one year during which companies adjusted those amounts as additional information became available in the reporting period within the measurement period in which such adjustment is determined.

Under GAAP, we were required to revalue our net deferred tax asset associated with our U.S. net deductible temporary differences in the period in which the new tax legislation was enacted based on deferred tax balances as of the enactment date, to reflect the effect of such reduction in the corporate income tax rate. Our net deductible temporary differences as of December 31, 2017 were not materially different from our net deductible temporary differences as of the enactment date, accordingly revaluation of our net deductible temporary differences was based on our net deferred tax assets as of December 31, 2017. Such revaluation was recognized in continuing operations and was not material to us. Such revaluation resulted in a provisional non-cash deferred income tax benefit of \$77.1 million recognized as of December 31, 2017 in continuing operations, reducing our net deferred income tax liability. The amounts recorded as of December 31, 2017 as a result of the 2017 Tax Act represented estimates based on information then available. During the third quarter of 2018, in conjunction with finalizing our federal income tax return we were able to obtain, prepare and analyze the necessary information to complete the accounting under ASC 740 related to the revaluation of our net deferred tax liability associated with our U.S. net taxable temporary differences as of December 31, 2017, which resulted in a measurement period adjustment and recognition of a non-cash deferred income tax expense of \$59.7 million, decreasing the provisional amount recognized at December 31, 2017. Such adjustment is almost entirely attributable to the re-measurement of our deferred income taxes with respect to the excess of the financial reporting carrying amount over the income tax basis of our direct investment in Kronos common stock discussed below. Accordingly, we completed our analysis related to such revaluation as of September 30, 2018.

Prior to the enactment of the 2017 Tax Act the undistributed earnings of our Chemicals Segment's European subsidiaries were deemed to be permanently reinvested (we had not made a similar determination with respect to the undistributed earnings of our Chemicals Segment's Canadian subsidiary). Pursuant to the Transition Tax provisions imposing a one-time repatriation tax on post-1986 undistributed earnings, we recognized a provisional current income tax expense of \$76.2 million in the fourth quarter of 2017. The amounts recorded as of December 31, 2017 as a result of the 2017 Tax Act represented estimates based on information available at that date. We elected to pay such tax over an eight year period beginning in 2018. During the third quarter of 2018, in conjunction with finalizing our federal income tax return and based on additional information that became available (including proposed regulations issued by the IRS in August 2018 with respect to the Transition Tax), we recognized a provisional income tax benefit of \$2.1 million which amount is recorded as a measurement-period adjustment, reducing the provisional income tax expense of \$76.2 million recognized in the fourth quarter of 2017. Pursuant to IRS guidance issued in 2019, our Transitional Tax installment for the 2019 tax year is due in April 2020. Prior to the issuance of the new guidance, we anticipated paying such installment in 2019. Consequently, at December 31, 2019, taking into account the prior Transition Tax installments payments, the balance of our unpaid Transition Tax has not changed from the balance at December 31, 2018 and aggregates \$62.2 million, which will be paid in annual installments over the remainder of the eight year period. Of such \$62.2 million, \$56.3 million is recorded as a noncurrent payable to affiliate (income taxes payable to Contran) classified as a noncurrent liability in our Consolidated Balance Sheet, and \$5.9 million is included with our current payable to affiliate (income taxes payable to Contran) classified as a current liability (a portion of our

noncurrent income tax payable to affiliate was reclassified to our current payable to affiliate for the portion of our 2019 Transition Tax installment due within the next twelve months). We completed our analysis of the Transition Tax provisions within the prescribed measurement period ending December 22, 2018 pursuant to the guidance under SAB 118.

As a result of the implementation of a territorial tax system under the 2017 Tax Act, effective January 1, 2018, and the Transition Tax which in effect taxes the post-1986 undistributed earnings of our non-U.S. subsidiaries accumulated up through December 31, 2017, we determined effective December 31, 2017 that all of the post-1986 undistributed earnings of our Chemicals Segment's European subsidiaries are not permanently reinvested. Accordingly, in the fourth quarter of 2017 we recognized an aggregate provisional non-cash deferred income tax expense of \$5.3 million based on our reasonable estimates of the U.S. state and non-U.S. income tax and withholding tax liability attributable to all of such previously-considered permanently reinvested undistributed earnings through December 31, 2017. The amounts recorded as of December 31, 2017 as a result of the 2017 Tax Act represented estimates based on information available at that date. We did not make any measurement-period adjustments to the provisional amounts recorded at December 31, 2017 for this item during 2018 because no new information became available during the period that required an adjustment. However, we recorded a non-cash deferred income tax expense of \$1.8 million for the U.S. state and non-U.S. income tax and withholding tax liability attributable to the 2018 undistributed earnings of our Chemicals Segment's non-U.S. subsidiaries in 2018, including withholding taxes related to the undistributed earnings of our Chemicals Segment's Canadian subsidiary. We completed our analysis as it relates to the implementation of a territorial tax system under the 2017 Tax Act within the prescribed measurement period ending December 22, 2018 pursuant to the guidance under SAB 118.

We record GILTI tax as a current-period expense when incurred under the period cost method. We have evaluated the tax impact of GILTI and BEAT provisions and related U.S. tax credit provisions applicable to tax years beginning in 2018 based on the relevant statutes. We recognized a current cash income tax expense of \$4.0 million and \$1.8 million for GILTI in 2018 and 2019, respectively. While our future global operations depend on a number of different factors, we do expect to have future U.S. inclusions in taxable income related to GILTI. Similarly, we have evaluated the tax impact of BEAT and determined that the tax imposed under BEAT has no material impact to us as we have historically not entered into international payments between related parties that are unrelated to cost of sales. Our determinations under the GILTI, BEAT and related non-U.S. tax credit provisions are based on the relevant statutes and guidance provided under the regulations.

Certain U.S. deferred tax attributes of one of our Chemicals Segment's non-U.S. subsidiaries, which subsidiary is treated as a dual resident for U.S. income tax purposes, were subject to various limitations. As a result, we had previously concluded that a deferred income tax asset valuation allowance was required to be recognized with respect to such subsidiary's U.S. net deferred income tax asset because such assets did not meet the more-likely-than-not recognition criteria primarily due to (i) the various limitations regarding use of such attributes due to the dual residency; (ii) the dual resident subsidiary had a history of losses and absent distributions from our non-U.S. subsidiaries, which were previously not determinable, such subsidiary was expected to continue to generate losses; and (iii) a limited NOL carryforward period for U.S. tax purposes. Because we had concluded the likelihood of realization of such subsidiary's net deferred income tax asset was remote, we had not previously disclosed such valuation allowance or the associated amount of the subsidiary's net deferred income tax assets (exclusive of such valuation allowance). Primarily due to changes enacted under the 2017 Tax Act, we concluded we had sufficient positive evidence under the more-likely-than-not recognition criteria to support reversal of the entire valuation allowance related to such subsidiary's net deferred income tax asset, which evidence included, among other things, (i) the inclusion under Transition Tax provisions of significant earnings for U.S. income tax purposes which significantly and positively impacts the ability of such deferred tax attributes to be utilized by us; (ii) the indefinite carryforward period for U.S. net operating losses incurred after December 31, 2017; (iii) an expectation of continued future profitability for our U.S. operations; and (iv) a positive taxable income basket for U.S. tax purposes in excess of the U.S. deferred tax asset related to the U.S. attributes of such subsidiary. Accordingly, in the fourth quarter of 2017 we recognized an \$18.7 million non-cash deferred income tax benefit as a result of the reversal of such valuation allowance.

The 2017 Tax Act amended the rules limiting the deduction for business interest expense beginning in 2018. The limitation applies to all taxpayers and our annual deduction for business interest expense is limited to the sum of our business interest income and 30% of our adjusted taxable income as defined under the 2017 Tax Act. Any business interest expense not allowed as a deduction as a result of the limitation may be carried forward indefinitely and is treated as interest paid in the carryforward year subject to the respective year's limitation. We determined that our interest expense for 2018 and 2019 was limited under these provisions. The limitation in 2018 resulted in part because of the loss we recognized on the sale of WCS for income tax purposes and the limitation in 2019 is primarily attributable to lower earnings. We have concluded that we are required to recognize a non-cash deferred income tax asset valuation allowance under the more-likely-than-not recognition criteria with respect to a portion of our deferred tax asset attributable to the nondeductible amount of business interest expense carryforward. Consequently, our provision for income taxes includes a non-cash deferred income tax expense of \$6.8 million in 2018 and \$4.5 million in 2019 for the amount of deferred income tax asset that does not meet the more-likely-than-not recognition criteria. In accordance with the ASC 740 guidance regarding intra-period allocation of income taxes, the full amount of non-cash deferred income tax expense in 2018 is classified as part of the income



taxes associated with the pre-tax gain we recognized for financial reporting purposes on the sale of WCS which is classified as part of discontinued operations (see Note 3 to our Consolidated Financial Statements and Discontinued Operations —Waste Control Specialists LLC).

In the fourth quarter of 2019, we recognized an income tax benefit of \$3.0 million primarily related to the favorable settlement of a prior year tax matter in Germany, with \$1.5 million recognized as a current cash tax benefit and \$1.5 million recognized as a non-cash deferred income tax benefit related to an increase to our German net operating loss carryforward. In addition, we recognized a non-cash deferred income tax expense of \$4.7 million primarily related to the revaluation of our net deferred income tax asset in Germany resulting from a decrease in the German trade tax rate.

At December 31, 2019, none of our U.S. and non-U.S. tax returns were under examination. As a result of prior audits in certain jurisdictions, which are now settled, in 2008 we filed Advance Pricing Agreement Requests with the tax authorities in the U.S., Canada and Germany. These requests have been under review with the respective tax authorities since 2008 and prior to 2016, it was uncertain whether an agreement would be reached between the tax authorities and whether we would agree to execute and finalize such agreements.

- During the third quarter of 2017, Kronos' Canadian subsidiary executed and finalized an Advance Pricing Agreement with the Competent Authority for Canada (the "Canada-Germany APA") effective for tax years 2005 - 2017. Pursuant to the terms of the Canada-Germany APA, the Canadian and German tax authorities agreed to certain prior year changes to taxable income of our Canadian and German subsidiaries. As a result of such agreed-upon changes, we reversed a significant portion of our reserve for uncertain tax positions and recognized a non-cash income tax benefit of \$8.6 million related to such reversal (\$8.1 million recognized in the third quarter of 2017). In addition, we recognized a \$2.6 million non-cash income tax benefit related to an increase in our German NOLs and a \$.6 million German cash tax refund related to the Canada-Germany APA in the third quarter of 2017.
- During the first quarter of 2018, Kronos' German subsidiary executed and finalized the related Advance Pricing Agreement with the Competent Authority for Germany (the "Germany-Canada APA") effective for tax years 2005 - 2017. In the first quarter of 2018, we recognized a net \$1.4 million non-cash income tax benefit related to an APA tax settlement payment between Kronos' German and Canadian subsidiaries.

We recognized a non-cash deferred income tax benefit of \$1.8 million in 2018 related to a decrease in our effective state income tax rate; this decrease is a direct result of the sale of our interest in the Amalgamated Sugar Company LLC which reduced the number of state jurisdictions in which we are required to file.

We recognize deferred income taxes with respect to the excess of the financial reporting carrying amount over the income tax basis of our direct investment in Kronos common stock because the exemption under GAAP to avoid such recognition of deferred income taxes is not available to us. At December 31, 2019, we have recognized a deferred income tax liability with respect to our direct investment in Kronos of \$37.8 million. There is a maximum amount (or cap) of such deferred income taxes we are required to recognize with respect to our direct investment in Kronos. The maximum amount of such deferred income tax liability we would be required to have recognized (the cap) is \$155.4 million (the cap was reduced as a result of the decrease in our effective state tax rate in the third quarter of 2018 discussed above). During 2019, we recognized a non-cash deferred income tax expense with respect to our direct investment in Kronos of \$.1 million for the increase in the deferred income taxes required to be recognized with respect to the excess of the financial reporting carrying amount over the income tax basis of our direct investment in Kronos common stock, to the extent such increase related to our equity in Kronos' net income during such period. We recognized a similar non-cash deferred income tax expense of \$4.9 million in 2018 and \$22.1 million in 2017. A portion of the net change with respect to the excess of the financial reporting carrying amount over the income tax basis of our direct investment in Kronos common stock during such periods related to our equity in Kronos' other comprehensive income (loss) items, and the amounts shown in the table above for income tax expense (benefit) allocated to other comprehensive income (loss) items includes amounts related to our equity in Kronos' other comprehensive income (loss) items. Due to uncertainties and complexities of the 2017 Tax Act, we were still evaluating the impact of the one-time deemed repatriation of the post-1986 undistributed earnings of our non-U.S. subsidiaries up through December 31, 2017 as it relates to the income tax basis of our direct investment in Kronos at December 31, 2017. During the third quarter of 2018, in conjunction with finalizing our federal income tax return and based on additional information that became available (including proposed regulations issued by the IRS in August 2018 with respect to the Transition Tax), we recognized an adjustment, which was treated as a measurement period adjustment, to the deferred income taxes we recognized at December 31, 2017 associated with our direct investment in Kronos common stock (before revaluation of our deferred tax liability related to the decrease in the corporate income tax rate). Such adjustment resulted in an investment basis adjustment under the income tax regulations which increased the income tax basis of our direct investment in Kronos attributable to the income recognition related to the deemed repatriation of the post-1986 undistributed earnings of our non-U.S. subsidiaries in 2017. Such adjustment resulted in a non-cash deferred tax measurement period adjustment decreasing the deferred income taxes we recognize with respect to the excess of the financial reporting carrying amount over the income tax basis of our direct investment in Kronos common stock. Including the impact of the

non-cash deferred tax revaluation adjustment discussed above, we recognized a net non-cash deferred income tax benefit of \$112 million in the third quarter of 2018 related to the incremental tax on Kronos. We completed our analysis related to the impact of the 2017 Tax Act as it related to the income tax basis of our direct investment in Kronos as of September 30, 2018.

We believe we have adequate accruals for additional taxes and related interest expense which could ultimately result from tax examinations. We believe the ultimate disposition of tax examinations should not have a material adverse effect on our consolidated financial position, results of operations or liquidity.

The following table shows the changes in the amount of our uncertain tax positions (exclusive of the effect of interest and penalties) during 2017, 2018 and 2019:

	Years ended December 31,		
	2017	2018	2019
	(In millions)		
Unrecognized tax benefits:			
Amount at beginning of year	\$ 35.6	\$ 17.1	\$ 21.0
Net increase (decrease):			
Tax positions taken in prior periods	(13.3)	1.3	(5.6)
Tax positions taken in current period	4.5	4.5	.7
Lapse due to applicable statute of limitations	(8.1)	(1.8)	-
Settlement with taxing authorities	(2.3)	-	(2.2)
Changes in currency exchange rates	.7	(.1)	(.1)
Amount at end of year	<u>\$ 17.1</u>	<u>\$ 21.0</u>	<u>\$ 13.8</u>

If our uncertain tax positions were recognized, a benefit of \$13.2 million at December 31, 2019, would affect our effective income tax rate. We currently estimate that our unrecognized tax benefits will decrease by approximately \$4.3 million, excluding interest, during the next twelve months related to the expiration of certain statutes of limitations.

We and Contran file income tax returns in U.S. federal and various state and local jurisdictions. We also file income tax returns in various foreign jurisdictions, principally in Germany, Canada, Belgium and Norway. Our U.S. income tax returns prior to 2016 are generally considered closed to examination by applicable tax authorities. Our foreign income tax returns are generally considered closed to examination for years prior to: 2010 for Norway; 2014 for Canada; 2015 for Germany; and 2016 for Belgium.

We accrue interest and penalties on our uncertain tax positions as a component of our provision for income taxes. We accrued interest and penalties of \$2.1 million during 2017, \$1.3 million during each of 2018 and 2019, and at December 31, 2018 and 2019 we had \$2.2 million and \$1.9 million, respectively, accrued for interest and an immaterial amount accrued for penalties for our uncertain tax positions.

**Note 15—Noncontrolling interest in subsidiaries:**

	December 31,	
	2018	2019
	(In millions)	
Noncontrolling interest in net assets:		
Kronos Worldwide	\$ 221.4	\$ 216.6
NL Industries	62.4	65.8
CompX International	19.4	22.7
BMI	27.1	20.1
LandWell	23.3	14.9
Total	<u>\$ 353.6</u>	<u>\$ 340.1</u>

	Years ended December 31,		
	2017	2018	2019
	(In millions)		
Noncontrolling interest in net income (loss) of subsidiaries:			
Kronos Worldwide	\$ 69.3	\$ 39.9	\$ 16.9
NL Industries	19.7	(7.0)	4.4
CompX International	1.7	2.0	2.2
BMI	3.2	1.5	2.2
LandWell	1.2	2.4	3.3
Total	<u>\$ 95.1</u>	<u>\$ 38.8</u>	<u>\$ 29.0</u>

**Note 16—Valhi stockholders' equity:**

	Shares of common stock		
	Issued	Treasury	Outstanding
	(In millions)		
Balance at December 31, 2017 and 2018	355.3	(13.2)	342.0
Director shares issued	.1	-	.1
Balance at December 31, 2019	<u>355.4</u>	<u>(13.2)</u>	<u>342.1</u>

*Valhi common stock.* We issued a nominal number of shares of Valhi common stock during 2017, 2018 and 2019, associated with annual stock awards to members of our board of directors.

*Valhi share repurchases and cancellations.* Prior to 2017, our board of directors authorized the repurchase of up to 10.0 million shares of our common stock in open market transactions, including block purchases, or in privately negotiated transactions, which may include transactions with our affiliates or subsidiaries. We may purchase the stock from time to time as market conditions permit. The stock repurchase program does not include specific price targets or timetables and may be suspended at any time. Depending on market conditions, we may terminate the program prior to completion. We will use cash on hand to acquire the shares. Repurchased shares could be retired and cancelled or may be added to our treasury stock and used for employee benefit plans, future acquisitions or other corporate purposes. We did not make any such purchases under the plan in 2017, 2018 or 2019.

*Treasury stock.* At December 31, 2018 and 2019, NL and Kronos held approximately 14.4 million and 1.7 million shares of our common stock, respectively. The treasury stock we reported for financial reporting purposes at December 31, 2018 and 2019 represents our proportional interest in these shares of our common stock held by NL and Kronos, at NL's and Kronos' historical cost basis. The remaining portion of these shares of our common stock, which are attributable to the noncontrolling interest of NL and Kronos, are reflected in our consolidated balance sheet at fair value and are classified as part of other noncurrent assets. Under Delaware Corporation Law, 100% (and not the proportionate interest) of a parent company's shares held by a majority-owned subsidiary of the parent is considered to be treasury stock for voting purposes. As a result, our common shares outstanding for financial reporting purposes differ from those outstanding for legal purposes. Prior to 2018, any unrealized gains or losses on the shares of our common stock attributable to the noncontrolling interest of Kronos and NL were recognized through other comprehensive income or loss, net of deferred income taxes, attributable to such noncontrolling interests. Beginning on January 1, 2018 with the adoption of ASU 2016-01, *Financial Instruments – Overall (Subtopic 825-10): Recognition of Financial Assets and Financial Liabilities*, Kronos and NL recognize unrealized gains or losses in the determination of each of their respective net income or losses. Under the principles of consolidation we eliminate any gains or losses associated with our common stock to the extent of our proportional ownership interest in each subsidiary. We recognized a loss of \$12.2 million in 2018 and a loss of \$.2 million in 2019 in our Consolidated Statement of Income which represents the unrealized loss in respect of these shares attributable to the noncontrolling interest of Kronos and NL. See Note 2.

*Preferred stock.* Our outstanding preferred stock consists of 5,000 shares of our Series A Preferred Stock having a liquidation preference of \$133,466.75 per share, or an aggregate liquidation preference of \$667.3 million. The outstanding shares of Series A Preferred Stock are held by Contran and represent all of the shares of Series A Preferred Stock we are authorized to issue. The preferred stock has a par value of \$.01 per share and pays a non-cumulative cash dividend at an annual rate of 6% of the aggregate liquidation preference only when authorized and declared by our board of directors. The shares of Series A Preferred Stock are non-convertible, and the shares do not carry any redemption or call features (either at our option or the option of the holder). A holder of the Series A shares does not have any voting rights, except in limited circumstances, and is not entitled to a preferential dividend right that is senior to our shares of common stock. Upon the liquidation, dissolution or winding up of our affairs, a holder of the Series A shares is entitled to be paid a liquidation preference of \$133,466.75 per share, plus an amount (if any) equal to any declared but unpaid dividends, before any distribution of assets is made to holders of our common stock. Through December 31, 2019, we have not declared any dividends on the Series A Preferred Stock since its issuance prior to 2017.

*Valhi long-term incentive compensation plan.* Prior to 2017, our board of directors adopted a plan that provides for the award of stock to our board of directors, and up to a maximum of 200,000 shares could be awarded. Under the plan, we awarded 12,000 shares in 2017, 14,500 shares in 2018 and 50,000 shares in 2019, and at December 31, 2019, 74,000 shares are available for future award under this new plan.

*Stock plans of subsidiaries.* Kronos, NL and CompX each maintain plans which provide for the award of their common stock to their board of directors. At December 31, 2019, Kronos, NL and CompX had 140,900, 113,150 and 149,050 shares of their respective common stock available for future award under respective plans.

*Accumulated other comprehensive income (loss).* Accumulated other comprehensive income (loss) attributable to Valhi stockholders comprises changes in equity as presented in the table below.

	Years ended December 31,		
	2017	2018	2019
	(In millions)		
Accumulated other comprehensive income (loss) (net of tax and noncontrolling interest):			
Marketable securities:			
Balance at beginning of year	\$ 1.7	\$ 1.7	\$ 1.7
Other comprehensive income (loss):			
Unrealized gain arising during the year	-	-	-
Balance at end of year	<u>\$ 1.7</u>	<u>\$ 1.7</u>	<u>\$ 1.7</u>
Interest rate swap:			
Balance at beginning of year	\$ (1.2)	\$ -	\$ -
Other comprehensive loss:			
Unrealized losses during the year	(1.2)	-	-
Less reclassification adjustments for amounts included in interest expense	2.4	-	-
Balance at end of year	<u>\$ -</u>	<u>\$ -</u>	<u>\$ -</u>
Currency translation:			
Balance at beginning of year	\$ (88.5)	\$ (54.1)	\$ (75.6)
Other comprehensive gain (loss) arising during the year	34.4	(21.5)	(1.2)
Balance at end of year	<u>\$ (54.1)</u>	<u>\$ (75.6)</u>	<u>\$ (76.8)</u>
Defined benefit pension plans:			
Balance at beginning of year	\$ (137.0)	\$ (129.0)	\$ (134.0)
Other comprehensive income (loss):			
Amortization of prior service cost and net (gains) losses included in net periodic pension cost	6.4	7.6	7.2
Net actuarial gain (loss) arising during the year	1.6	(12.6)	(19.8)
Balance at end of year	<u>\$ (129.0)</u>	<u>\$ (134.0)</u>	<u>\$ (146.6)</u>
OPEB plans:			
Balance at beginning of year	\$ 3.1	\$ 2.4	\$ 1.7
Other comprehensive loss:			
Amortization of prior service credit and net losses included in net periodic OPEB cost	(.8)	(.8)	(.8)
Net actuarial gain arising during the year	.1	.1	.1
Balance at end of year	<u>\$ 2.4</u>	<u>\$ 1.7</u>	<u>\$ 1.0</u>
Total accumulated other comprehensive income (loss):			
Balance at beginning of year	\$ (221.9)	\$ (179.0)	\$ (206.2)
Other comprehensive income (loss)	42.9	(27.2)	(14.5)
Balance at end of year	<u>\$ (179.0)</u>	<u>\$ (206.2)</u>	<u>\$ (220.7)</u>

See Note 11 for amounts related to our defined benefit pension plans, Note 10 for amounts related to our OPEB plans and Note 19 for a discussion of our interest rate swap contract.

#### Note 17—Related party transactions:

We may be deemed to be controlled by Ms. Simmons, Ms. Connelly and the Family Trust. See Note 1. Corporations that may be deemed to be controlled by or affiliated with such individuals sometimes engage in (a) intercorporate transactions such as guarantees, management and expense sharing arrangements, shared fee arrangements, joint ventures, partnerships, loans, options, advances of funds on open account, and sales, leases and exchanges of assets, including securities issued by both related and unrelated parties and (b) common investment and acquisition strategies, business combinations, reorganizations, recapitalizations, securities repurchases, and purchases and sales (and other acquisitions and dispositions) of subsidiaries, divisions or other business units, which transactions have involved both related and unrelated parties and have included transactions which resulted in the acquisition by one related party of a publicly-held noncontrolling interest in another related party. While no transactions of the type described above are

planned or proposed with respect to us other than as set forth in these financial statements, we continuously consider, review and evaluate, and understand that Contran and related entities consider, review and evaluate such transactions. Depending upon the business, tax and other objectives then relevant, it is possible that we might be a party to one or more such transactions in the future.

From time to time, we may have loans and advances outstanding between us and various related parties, including Contran, pursuant to term and demand notes. We generally enter into these loans and advances for cash management purposes. When we loan funds to related parties, we are generally able to earn a higher rate of return on the loan than we would earn if we invested the funds in other instruments. While certain of these loans may be of a lesser credit quality than cash equivalent instruments otherwise available to us, we believe we have evaluated the credit risks involved and appropriately reflect those credit risks in the terms of the applicable loans. When we borrow from related parties, we are generally able to pay a lower rate of interest than we would pay if we borrowed from unrelated parties. See Note 9 for more information on the Valhi credit facility with Contran. We paid Contran \$14.6 million, \$18.9 million and \$19.9 million in interest on borrowings and unused commitment fees under credit facilities in 2017, 2018 and 2019, respectively.

We and a subsidiary of Contran have guaranteed (i) Tremont's obligation under its \$2.0 million promissory note payable to NERT discussed in Note 9 and (ii) Tremont's \$9.9 million (\$11.1 million face value) deferred payment obligation discussed in Note 10. The guaranty obligation would only arise upon Tremont's failure to make any required repayments.

Under the terms of various intercorporate services agreements ("ISAs") we enter into with Contran, employees of Contran provide us certain management, tax planning, financial and administrative services on a fee basis. Such charges are based upon estimates of the time devoted by the Contran employees to our affairs, and the compensation and other expenses associated with those persons. Because of the number of companies affiliated with Contran, we believe we benefit from cost savings and economies of scale gained by not having certain management, financial and administrative staffs duplicated at all of our subsidiaries, thus allowing certain Contran employees to provide services to multiple companies but only be compensated by Contran. The net ISA fees charged to us by Contran aggregated \$40.0 million in 2017, \$39.6 million in 2018 and \$43.9 in 2019.

We had an aggregate 25.0 million shares at December 31, 2019 of our Kronos common stock pledged as collateral for certain debt obligations of Contran. We receive a fee from Contran for pledging these Kronos shares, determined by a formula based on the market value of the shares pledged. We received \$2.8 million in 2017, \$3.1 million in 2018 and \$1.9 million in 2019 from Contran for this pledge.

Our subsidiaries Tall Pines Insurance Company and EWI RE, Inc. provide for or broker certain insurance or reinsurance policies for Contran and certain of its subsidiaries and affiliates, including us. Tall Pines purchases reinsurance for substantially all of the risks it underwrites from third party insurance carriers with an A.M. Best Company rating of generally at least A- (Excellent). Consistent with insurance industry practices, Tall Pines and EWI receive commissions from insurance and reinsurance underwriters and/or assess fees for the policies that they provide or broker to us. Prior to NL's sale of EWI's insurance and risk management business to a third party in November 2019, EWI brokered certain of our insurance policies, provided claims and risk management services and, where appropriate, engaged certain third-party risk management consultants. We received cash payments for insurance premiums from Contran and certain other affiliates not members of our consolidated financial reporting group of \$5.9 million in 2017, \$5.4 million in 2018 and \$0.7 million in 2019. These amounts also include payments to insurers or reinsurers through EWI for the reimbursement of claims within our applicable deductible or retention ranges that such insurers or reinsurers paid to third parties on our behalf, as well as amounts for claims and risk management services and various other third-party fees and expenses incurred by the program. We expect that the relationship with Tall Pines will continue in 2020, except that a third-party brokerage and risk management company is now the broker for Contran's insurance policies and Tall Pines' reinsurance policies.

With respect to certain of such jointly-owned policies, it is possible that unusually large losses incurred by one or more insureds during a given policy period could leave the other participating companies without adequate coverage under that policy for the balance of the policy period. As a result, and in the event that the available coverage under a particular policy would become exhausted by one or more claims, Contran and certain of its subsidiaries and affiliates, including us, have entered into a loss sharing agreement under which any uninsured loss arising because the available coverage had been exhausted by one or more claims will be shared ratably amongst those entities that had submitted claims under the relevant policy. We believe the benefits in the form of reduced premiums and broader coverage associated with the group coverage for such policies justify the risk associated with the potential for any uninsured loss.

Contran and certain of its subsidiaries participate in a combined information technology data recovery program that Contran provides from a data recovery center that it established. Pursuant to the program, Contran and certain of its subsidiaries, as a group, share information technology data recovery services. The program apportions its costs among the participating companies. We paid Contran \$0.3 million in 2017 and 2018 and \$0.2 million in 2019 for such services. Under the terms of a sublease agreement between

Contran and Kronos, Kronos leases certain office space from Contran. In 2019, Kronos paid Contran \$.1 million for such rent and related ancillary services. We expect that these relationships with Contran will continue in 2020.

Receivables from and payables to affiliates are summarized in the table below.

	December 31,	
	2018	2019
	(In millions)	
Current receivables from affiliates:		
Contran trade items	\$ .5	\$ .4
Louisiana Pigment Company, L.P.	10.2	4.7
Other	2.8	2.2
Total	<u>\$ 13.5</u>	<u>\$ 7.3</u>
Current payables to affiliates:		
Louisiana Pigment Company, L.P.	\$ 16.7	\$ 16.4
Contran income taxes	10.0	4.0
Total	<u>\$ 26.7</u>	<u>\$ 20.4</u>
Noncurrent payable to affiliates:		
Contran - income taxes	<u>\$ 56.3</u>	<u>\$ 56.3</u>
Payables to affiliate included in long-term debt		
Valhi - Contran credit facility	<u>\$ 314.3</u>	<u>\$ 313.0</u>

Amounts payable to LPC are generally for the purchase of TiO<sub>2</sub>, while amounts receivable from LPC are generally from the sale of TiO<sub>2</sub> feedstock. See Note 7. Purchases of TiO<sub>2</sub> from LPC were \$157.5 million in 2017, \$165.9 million in 2018 and \$176.2 million in 2019. Sales of feedstock to LPC were \$79.4 million in 2017, \$66.9 million in 2018 and \$84.1 million in 2019. The noncurrent payable to Contran for income taxes is discussed in Note 14.

#### **Note 18—Commitments and contingencies:**

##### ***Lead pigment litigation***

Our former operations included the manufacture of lead pigments for use in paint and lead-based paint. We, other former manufacturers of lead pigments for use in paint and lead-based paint (together, the “former pigment manufacturers”), and the Lead Industries Association (LIA), which discontinued business operations in 2002, have been named as defendants in various legal proceedings seeking damages for personal injury, property damage and governmental expenditures allegedly caused by the use of lead-based paints. Certain of these actions have been filed by or on behalf of states, counties, cities or their public housing authorities and school districts, and certain others have been asserted as class actions. These lawsuits seek recovery under a variety of theories, including public and private nuisance, negligent product design, negligent failure to warn, strict liability, breach of warranty, conspiracy/concert of action, aiding and abetting, enterprise liability, market share or risk contribution liability, intentional tort, fraud and misrepresentation, violations of state consumer protection statutes, supplier negligence and similar claims.

The plaintiffs in these actions generally seek to impose on the defendants responsibility for lead paint abatement and health concerns associated with the use of lead-based paints, including damages for personal injury, contribution and/or indemnification for medical expenses, medical monitoring expenses and costs for educational programs. To the extent the plaintiffs seek compensatory or punitive damages in these actions, such damages are generally unspecified. In some cases, the damages are unspecified pursuant to the requirements of applicable state law. A number of cases are inactive or have been dismissed or withdrawn. Most of the remaining cases are in various pre-trial stages. Some are on appeal following dismissal or summary judgment rulings or a trial verdict in favor of either the defendants or the plaintiffs.

We believe that these actions are without merit, and we intend to continue to deny all allegations of wrongdoing and liability and to defend against all actions vigorously. Other than with respect to the Santa Clara, California public nuisance case discussed below, we do not believe it is probable that we have incurred any liability with respect to all of the lead pigment litigation cases to which we are a party, and with respect to all such lead pigment litigation cases to which we are a party, other than with respect to the Santa Clara case discussed below, we believe liability to us that may result, if any, in this regard cannot be reasonably estimated, because:

- we have never settled any of the market share, intentional tort, fraud, nuisance, supplier negligence, breach of warranty, conspiracy, misrepresentation, aiding and abetting, enterprise liability, or statutory cases,
- no final, non-appealable adverse verdicts have ever been entered against us, and
- we have never ultimately been found liable with respect to any such litigation matters, including over 100 cases over a twenty-year period for which we were previously a party and for which we have been dismissed without any finding of liability.

Accordingly, other than with respect to the Santa Clara case discussed below, we have not accrued any amounts for any of the pending lead pigment and lead-based paint litigation cases filed by or on behalf of states, counties, cities or their public housing authorities and school districts, or those asserted as class actions. In addition, we have determined that liability to us which may result, if any, cannot be reasonably estimated at this time because there is no prior history of a loss of this nature on which an estimate could be made and there is no substantive information available upon which an estimate could be based.

In the matter titled *County of Santa Clara v. Atlantic Richfield Company, et al.* (Superior Court of the State of California, County of Santa Clara, Case No. 1-00-CV-788657) on July 24, 2019, an order approving a global settlement agreement entered into among all of the plaintiffs and the three defendants remaining in the case (the Sherwin Williams Company, ConAgra Grocery Products and NL) was entered by the court and the case was dismissed with prejudice. The global settlement agreement provides that an aggregate \$305 million will be paid collectively by the three co-defendants in full satisfaction of all claims resulting in a dismissal of the case with prejudice and the resolution of (i) all pending and future claims by the plaintiffs in the case, and (ii) all potential claims for contribution or indemnity between NL and its co-defendants in respect to the case. In the agreement, NL expressly denies any and all liability and the dismissal of the case with prejudice was entered by the court without a final judgment of liability entered against NL. The settlement agreement fully concludes this matter.

Under the terms of the global settlement agreement, each defendant must pay an aggregate \$101.7 million to the plaintiffs as follows: \$25.0 million within sixty days of the court's approval of the settlement and dismissal of the case, and the remaining \$76.7 million in six annual installments beginning on the first anniversary of the initial payment (\$12.0 million for the first five installments and \$16.7 million for the sixth installment). NL's sixth installment will be made with funds already on deposit at the court that are committed to the settlement, including all accrued interest at the date of payment, with any remaining balance to be paid by NL (and any amounts on deposit in excess of the final payment would be returned to NL).

As previously disclosed during the second quarter of 2018 and based on the terms of a May 2018 settlement agreement between NL and the plaintiffs which had an aggregate cost of \$80 million to NL, we determined that the loss to NL could be reasonably estimated and recognized a net \$62 million pre-tax charge with respect to this matter (\$45 million for the amount to be paid by NL upon approval of the terms of the settlement and \$17 million for the net present value of the five payments aggregating \$20 million to be paid by NL in installments beginning four years from such approval). The May 2018 settlement was never approved by the court and was superseded in July 2019 by the global settlement agreement discussed above.

At June 30, 2019, based on the terms of the global settlement agreement approved by the court in July 2019 we increased the amount accrued for the litigation settlement and a final immaterial adjustment was made to the litigation settlement accrual in the third quarter of 2019. For financial reporting purposes, using a discount rate of 1.9% per annum, we discounted the aggregate \$101.7 million settlement to the estimated net present value of \$96.3 million. We recognized litigation settlement expense of \$19.3 million (\$19.6 million expense in the second quarter of 2019 and \$.3 million credit in the third quarter of 2019). NL made the initial \$25.0 million payment in September 2019 and recognized an aggregate of \$.6 million in accretion expense in the second half of 2019.

For purposes of our Consolidated Balance Sheet at December 31, 2019, we have recognized the net present value of the \$12.0 million payment due in 2020, \$11.8 million, as a current liability and the net present value of the five remaining annual installments, \$60.1 million, as a noncurrent liability. Under the terms of the settlement, we reclassified the \$15.6 million on deposit at the court from an accrued insurance receivable to noncurrent restricted cash during the third quarter. Pursuant to the settlement agreement, also during the third quarter of 2019 NL placed an additional \$9.0 million into an escrow account which is included in noncurrent restricted cash on our Consolidated Balance Sheet.

In November 2018, NL was served with two complaints filed by county governments in Pennsylvania. Each county alleges that NL and several other defendants created a public nuisance by selling and promoting lead-containing paints and pigments in the counties. The plaintiffs seek abatement and declaratory relief. We believe these lawsuits are inconsistent with Pennsylvania law and without merit, and we intend to defend ourselves vigorously.

New cases may continue to be filed against us. We cannot assure you that we will not incur liability in the future in respect of any of the pending or possible litigation in view of the inherent uncertainties involved in court and jury rulings. In the future, if



new information regarding such matters becomes available to us (such as a final, non-appealable adverse verdict against us or otherwise ultimately being found liable with respect to such matters), at that time we would consider such information in evaluating any remaining cases then-pending against us as to whether it might then have become probable we have incurred liability with respect to these matters, and whether such liability, if any, could have become reasonably estimable. The resolution of any of these cases could result in the recognition of a loss contingency accrual that could have a material adverse impact on our net income for the interim or annual period during which such liability is recognized and a material adverse impact on our consolidated financial condition and liquidity.

### ***Environmental matters and litigation***

Our operations are governed by various environmental laws and regulations. Certain of our businesses are and have been engaged in the handling, manufacture or use of substances or compounds that may be considered toxic or hazardous within the meaning of applicable environmental laws and regulations. As with other companies engaged in similar businesses, certain of our past and current operations and products have the potential to cause environmental or other damage. We have implemented and continue to implement various policies and programs in an effort to minimize these risks. Our policy is to maintain compliance with applicable environmental laws and regulations at all of our plants and to strive to improve environmental performance. From time to time, we may be subject to environmental regulatory enforcement under U.S. and non-U.S. statutes, the resolution of which typically involves the establishment of compliance programs. It is possible that future developments, such as stricter requirements of environmental laws and enforcement policies, could adversely affect our production, handling, use, storage, transportation, sale or disposal of such substances. We believe that all of our facilities are in substantial compliance with applicable environmental laws.

Certain properties and facilities used in NL's former operations, including divested primary and secondary lead smelters and former mining locations, are the subject of civil litigation, administrative proceedings or investigations arising under federal and state environmental laws and common law. Additionally, in connection with past operating practices, we are currently involved as a defendant, potentially responsible party ("PRP") or both, pursuant to the Comprehensive Environmental Response, Compensation and Liability Act, as amended by the Superfund Amendments and Reauthorization Act ("CERCLA"), and similar state laws in various governmental and private actions associated with waste disposal sites, mining locations, and facilities that we or our predecessors, our subsidiaries or their predecessors currently or previously owned, operated or used, certain of which are on the United States Environmental Protection Agency's ("EPA") Superfund National Priorities List or similar state lists. These proceedings seek cleanup costs, damages for personal injury or property damage and/or damages for injury to natural resources. Certain of these proceedings involve claims for substantial amounts. Although we may be jointly and severally liable for these costs, in most cases we are only one of a number of PRPs who may also be jointly and severally liable, and among whom costs may be shared or allocated. In addition, we are occasionally named as a party in a number of personal injury lawsuits filed in various jurisdictions alleging claims related to environmental conditions alleged to have resulted from our operations.

Obligations associated with environmental remediation and related matters are difficult to assess and estimate for numerous reasons including the:

- complexity and differing interpretations of governmental regulations,
- number of PRPs and their ability or willingness to fund such allocation of costs,
- financial capabilities of the PRPs and the allocation of costs among them,
- solvency of other PRPs,
- multiplicity of possible solutions,
- number of years of investigatory, remedial and monitoring activity required,
- uncertainty over the extent, if any, to which our former operations might have contributed to the conditions allegedly giving rise to such personal injury, property damage, natural resource and related claims, and
- number of years between former operations and notice of claims and lack of information and documents about the former operations.

In addition, the imposition of more stringent standards or requirements under environmental laws or regulations, new developments or changes regarding site cleanup costs or the allocation of costs among PRPs, solvency of other PRPs, the results of future testing and analysis undertaken with respect to certain sites or a determination that we are potentially responsible for the release of hazardous substances at other sites, could cause our expenditures to exceed our current estimates. We cannot assure you that actual costs will not exceed accrued amounts or the upper end of the range for sites for which estimates have been made, and we cannot assure you that costs will not be incurred for sites where no estimates presently can be made. Further, additional environmental and related matters may arise in the future. If we were to incur any future liability, this could have a material adverse effect on our consolidated financial statements, results of operations and liquidity.

We record liabilities related to environmental remediation and related matters (including costs associated with damages for personal injury or property damage and/or damages for injury to natural resources) when estimated future expenditures are probable and reasonably estimable. We adjust such accruals as further information becomes available to us or as circumstances change. Unless the amounts and timing of such estimated future expenditures are fixed and reasonably determinable, we generally do not discount estimated future expenditures to their present value due to the uncertainty of the timing of the payout. We recognize recoveries of costs from other parties, if any, as assets when their receipt is deemed probable. At December 31, 2019, we had not recognized any material receivables and at December 31, 2018, we had recognized \$15.0 million of receivables for recoveries related to the California case discussed above.

We do not know and cannot estimate the exact time frame over which we will make payments for our accrued environmental and related costs. The timing of payments depends upon a number of factors, including but not limited to the timing of the actual remediation process; which in turn depends on factors outside of our control. At each balance sheet date, we estimate the amount of our accrued environmental and related costs which we expect to pay within the next twelve months, and we classify this estimate as a current liability. We classify the remaining accrued environmental costs as a noncurrent liability.

The table below presents a summary of the activity in our accrued environmental costs during 2017, 2018, and 2019 are presented below.

	<b>Years ended December 31,</b>		
	<b>2017</b>	<b>2018</b>	<b>2019</b>
	<b>(In millions)</b>		
Balance at the beginning of the year	\$ 122.6	\$ 117.5	\$ 103.4
Additions charged to expense, net	4.1	3.1	.3
Payments, net	(9.1)	(17.2)	(4.0)
Changes in currency exchange rates and other	(.1)	-	-
Balance at the end of the year	<u>\$ 117.5</u>	<u>\$ 103.4</u>	<u>\$ 99.7</u>
Amounts recognized in our Consolidated Balance Sheet at the end of the year:			
Current liabilities	\$ 6.8	\$ 6.5	\$ 4.5
Noncurrent liabilities	110.7	96.9	95.2
Total	<u>\$ 117.5</u>	<u>\$ 103.4</u>	<u>\$ 99.7</u>

*NL*—On a quarterly basis, NL evaluates the potential range of its liability for environmental remediation and related costs at sites where it has been named as a PRP or defendant. At December 31, 2019, NL had accrued approximately \$94.5 million related to approximately 32 sites associated with remediation and related matters that it believes are at the present time and/or in their current phase reasonably estimable. The upper end of the range of reasonably possible costs to NL for remediation and related matters for which NL believes it is possible to estimate costs is approximately \$115 million, including the amount currently accrued.

NL believes that it is not reasonably possible to estimate the range of costs for certain sites. At December 31, 2019, there were approximately five sites for which NL is not currently able to reasonably estimate a range of costs. For these sites, generally the investigation is in the early stages, and NL is unable to determine whether or not NL actually had any association with the site, the nature of its responsibility, if any, for the contamination at the site and the extent of contamination at and cost to remediate the site. The timing and availability of information on these sites is dependent on events outside of NL's control, such as when the party alleging liability provides information to NL. At certain of these previously inactive sites, NL has received general and special notices of liability from the EPA and/or state agencies alleging that NL, sometimes with other PRPs, are liable for past and future costs of remediating environmental contamination allegedly caused by former operations. These notifications may assert that NL, along with any other alleged PRPs, are liable for past and/or future clean-up costs. As further information becomes available to us for any of these sites which would allow us to estimate a range of costs, we would at that time adjust our accruals. Any such adjustment could result in the recognition of an accrual that would have a material effect on our consolidated financial statements, results of operations and liquidity.

*Other*—We have also accrued approximately \$5.2 million at December 31, 2019 for other environmental cleanup matters. This accrual is near the upper end of the range of our estimate of reasonably possible costs for such matters.

### ***Insurance coverage claims***

We are involved in certain legal proceedings with a number of our former insurance carriers regarding the nature and extent of the carriers' obligations to us under insurance policies with respect to certain lead pigment and asbestos lawsuits. The issue of whether insurance coverage for defense costs or indemnity or both will be found to exist for our lead pigment and asbestos litigation depends upon a variety of factors and we cannot assure you that such insurance coverage will be available.

We have agreements with three former insurance carriers pursuant to which the carriers reimburse us for a portion of our future lead pigment litigation defense costs, and one such carrier reimburses us for a portion of our future asbestos litigation defense costs. We are not able to determine how much we will ultimately recover from these carriers for defense costs incurred by us because of certain issues that arise regarding which defense costs qualify for reimbursement. While we continue to seek additional insurance recoveries, we do not know if we will be successful in obtaining reimbursement for either defense costs or indemnity. Accordingly, we recognize insurance recoveries in income only when receipt of the recovery is probable and we are able to reasonably estimate the amount of the recovery.

### ***Other litigation***

In addition to the litigation described above, we and our affiliates are involved in various other environmental, contractual, product liability, patent (or intellectual property), employment and other claims and disputes incidental to our present and former businesses. In certain cases, we have insurance coverage for these items, although we do not expect any additional material insurance coverage for our environmental claims. We currently believe that the disposition of all of these various other claims and disputes (including asbestos-related claims), individually or in the aggregate, should not have a material adverse effect on our consolidated financial position, results of operations or liquidity beyond the accruals already provided.

### **Other matters**

***Concentrations of credit risk***—Sales of TiO<sub>2</sub> accounted for approximately 94% of our Chemicals Segment's sales in each of 2017, 2018 and 2019. The remaining sales result from the mining and sale of ilmenite ore (a raw material used in the sulfate pigment production process), and the manufacture and sale of iron-based water treatment chemicals and certain titanium chemical products (derived from co-products of the TiO<sub>2</sub> production processes). TiO<sub>2</sub> is generally sold to the paint, plastics and paper industries. Such markets are generally considered "quality-of-life" markets whose demand for TiO<sub>2</sub> is influenced by the relative economic well-being of the various geographic regions. Our Chemicals Segment sells TiO<sub>2</sub> to over 4,000 customers, with the top ten customers approximating 34% of our Chemicals Segment's net sales in 2017, 33% in 2018 and 36% in 2019. Our Chemicals Segment did not have sales to a single customer comprising 10% or more of its net sales in each of 2017 and 2018. In 2019 one customer accounted for approximately 10% of our Chemicals Segment's net sales. The table below shows the approximate percentage of our Chemicals Segment's TiO<sub>2</sub> sales by volume for its significant markets, Europe and North America, for the last three years.

	<u>2017</u>	<u>2018</u>	<u>2019</u>
Europe	50 %	44 %	46 %
North America	31 %	37 %	34 %

Our Component Products Segment's products are sold primarily in North America to original equipment manufacturers. The ten largest customers related to our Component Product's Segment accounted for approximately 44% of our Component Products Segment's sales in each of 2017 and 2018 and 47% in 2019. One customer of the security products reporting unit accounted for approximately 16% of the Component Products Segment's total sales in 2017, 13% in 2018 and 14% in 2019.

Our Real Estate Management and Development Segment's revenues are land sales income and water and electric delivery fees. During 2017 we had sales to three customers that each exceeded 10% of our Real Estate Management and Development Segment's net sales related to land sales and one customer related to water delivery sales. During 2018 we had sales to three customers that each exceeded 10% of our Real Estate Management and Development Segment's net sales all related to land sales. During 2019 we had sales to three customers that each exceeded 10% of our Real Estate Management and Development Segment's net sales related to land sales and one customer related to water delivery sales.

***Long-term contracts***—Our Chemicals Segment has long-term supply contracts that provide for certain of its TiO<sub>2</sub> feedstock requirements through 2022. The agreements require Kronos to purchase certain minimum quantities of feedstock with minimum purchase commitments aggregating approximately \$897 million over the life of the contracts in years subsequent to December 31, 2019. In addition, our Chemicals Segment has other long-term supply and service contracts that provide for various raw materials and

services. These agreements require Kronos to purchase certain minimum quantities or services with minimum purchase commitments aggregating approximately \$74 million at December 31, 2019.

**Income taxes**—Prior to 2017, NL made certain pro-rata distributions to its stockholders in the form of shares of Kronos common stock. All of NL’s distributions of Kronos common stock were taxable to NL and NL recognized a taxable gain equal to the difference between the fair market value of the Kronos shares distributed on the various dates of distribution and NL’s adjusted tax basis in the shares at the dates of distribution. NL transferred shares of Kronos common stock to us in satisfaction of the tax liability related to NL’s gain on the transfer or distribution of these shares of Kronos common stock and the tax liability generated from the use of Kronos shares to settle the tax liability. To date, we have not paid the liability to Contran because Contran has not paid the liability to the applicable tax authority. The income tax liability will become payable to Contran, and by Contran to the applicable tax authority, when the shares of Kronos transferred or distributed by NL to us are sold or otherwise transferred outside the Contran Tax Group or in the event of certain restructuring transactions involving us. We have recognized deferred income taxes for our investment in Kronos common stock.

We are a party to a tax sharing agreement with Contran providing for the allocation of tax liabilities and tax payments as described in Note 1. Under applicable law, we, as well as every other member of the Contran Tax Group, are each jointly and severally liable for the aggregate federal income tax liability of Contran and the other companies included in the Contran Tax Group for all periods in which we are included in the Contran Tax Group. Contran has agreed, however, to indemnify us for any liability for income taxes of the Contran Tax Group in excess of our tax liability computed in accordance with the tax sharing agreement.

**Note 19—Financial instruments:**

The following table summarizes the valuation of our short-term investments and financial instruments by the ASC Topic 820 categories as of December 31, 2018 and 2019:

	<b>Fair Value Measurements</b>		
	<b>Total</b>	<b>Quoted prices in active markets (Level 1)</b>	<b>Significant other observable inputs (Level 2)</b>
	(In millions)		
<b>Asset (liability)</b>			
<b>December 31, 2018:</b>			
Marketable securities:			
Current	\$ 2.5	\$ -	\$ 2.5
Noncurrent	4.8	1.6	3.2
<b>December 31, 2019:</b>			
Marketable securities:			
Current	\$ 2.1	\$ -	\$ 2.1
Noncurrent	6.2	1.3	4.9

See Note 6 for information on how we determine the fair value of our marketable securities.

**Currency forward contracts** - Certain of our sales generated by our Chemicals Segment’s non-U.S. operations are denominated in U.S. dollars. Our Chemicals Segment periodically uses currency forward contracts to manage a very nominal portion of currency exchange rate risk associated with trade receivables denominated in a currency other than the holder’s functional currency or similar exchange rate risk associated with future sales. Derivatives that we use are primarily currency forward contracts and interest rate swaps. We have not entered into these contracts for trading or speculative purposes in the past, nor do we currently anticipate entering into such contracts for trading or speculative purposes in the future. Derivatives used to hedge forecasted transactions and specific cash flows associated with financial assets and liabilities denominated in currencies other than the U.S. dollar and which meet the criteria for hedge accounting are designated as cash flow hedges. Consequently, the effective portion of gains and losses is deferred as a component of accumulated other comprehensive income (loss) and is recognized in earnings at the time the hedged item affects earnings. Contracts that do not meet the criteria for hedge accounting are marked-to-market at each balance sheet date with any resulting gain or loss recognized in income currently as part of net currency transactions. The fair value of the currency forward contracts is determined using Level 1 inputs based on the currency spot forward rates quoted by banks or currency dealers.

At December 31, 2018 and 2019, Kronos had no currency forward contracts outstanding. We did not use hedge accounting for any of our contracts to the extent we held such contracts during 2017, 2018 and 2019.

**Interest rate swap contract** - As part of our interest rate risk management strategy, in August 2015 Kronos entered into a pay-fixed/receive-variable interest rate swap contract with Wells Fargo Bank, N.A. to minimize our exposure to volatility in LIBOR as it relates to our forecasted outstanding variable-rate indebtedness. Under this interest rate swap, we paid a fixed rate of 2.016% per annum, payable quarterly, and received a variable rate of three-month LIBOR (subject to a 1.00% floor), also payable quarterly, in each case based on the notional amount of the swap then outstanding. The effective date of the swap contract was September 30, 2015. The notional amount of the swap started at \$344.8 million and declined by \$875,000 each quarter beginning December 31, 2015, with an original final maturity of the swap contract in February 2020. This swap contract was designated as a cash flow hedge and qualified as an effective hedge at inception under ASC Topic 815 in respect of our term loan indebtedness. The effective portion of changes in fair value on this interest rate swap was recorded as a component of other comprehensive income, net of deferred income taxes. Commencing in the fourth quarter of 2015, as interest expense accrued on LIBOR-based variable rate debt, we classified the amount we paid under the pay-fixed leg of the swap and the amount we receive under the receive-variable leg of the swap as part of interest expense, with the net effect that the amount of interest expense we recognize on our LIBOR-based variable rate debt each quarter, as it relates to the notional amount of the swap outstanding each quarter, to be based on a fixed rate of 2.016% per annum in lieu of the level of LIBOR prevailing during the quarter.

In September 2017, in connection with the voluntary prepayment and termination of Kronos' term loan discussed in Note 9, Kronos voluntarily terminated this swap contract, as it no longer had any exposure to volatility in respect of LIBOR. The cost to us to early terminate the swap contract was \$3.3 million, which was paid to Wells Fargo concurrent with the termination. Such \$3.3 million charge is classified as part of our loss on prepayment of debt discussed in Note 9. Such \$3.3 million amount is also classified as part of the cash paid for interest disclosed in our Consolidated Statement of Cash Flows for the year ended December 31, 2017.

During 2017 (prior to the termination of the interest rate swap contract), a pretax unrealized loss arising during the period of \$2.3 million was recognized in other comprehensive income (loss) related to the interest rate swap. During such period \$2.1 million was reclassified from accumulated other comprehensive loss into earnings and is included in interest expense in our Consolidated Statements of Income. From the inception of the swap until the swap contract termination, there had been no gains or losses recognized in earnings representing hedge ineffectiveness with respect to the interest rate swap.

**Other** - The following table presents the financial instruments that are not carried at fair value but which require fair value disclosure as of December 31, 2018 and 2019:

	December 31, 2018		December 31, 2019	
	Carrying amount	Fair value	Carrying amount	Fair value
	(In millions)			
Cash, cash equivalents and restricted cash equivalents	\$ 523.7	\$ 523.7	\$ 583.8	\$ 583.8
Deferred payment obligation	9.6	9.6	9.9	9.9
Long-term debt (excluding capitalized leases):				
Kronos Senior Notes	452.4	412.9	442.6	457.0
Valhi credit facility with Contran	314.3	314.3	313.0	313.0
Tremont promissory note payable	9.4	9.4	2.0	2.0
BMI bank note payable	18.0	18.8	17.2	17.9
LandWell note payable to the City of Henderson	2.1	2.1	1.6	1.6
LandWell bank note payable	-	-	15.0	15.0

At December 31, 2019, the estimated market price of Kronos' Senior Notes was €1,020 per €1,000 principal amount. The fair value of Kronos' Senior Notes was based on quoted market prices; however, these quoted market prices represent Level 2 inputs because the markets in which the Senior Notes trade were not active. Fair values of variable interest rate debt and other fixed-rate debt are deemed to approximate book value. Due to their near-term maturities, the carrying amounts of accounts receivable and accounts payable are considered equivalent to fair value. See Notes 4 and 10.

**Note 20—Recent accounting pronouncements:**

*Adopted*

On January 1, 2019, we adopted ASU 2016-02, *Leases (Topic 842)*, which is a comprehensive rewriting of the lease accounting guidance which aims to increase comparability and transparency with regard to lease transactions. The primary change was the recognition of lease assets for the right-of-use of the underlying asset and lease liabilities for the obligation to make payments by lessees on the balance sheet for leases previously classified as operating leases. ASU 2016-02, as amended, also requires increased qualitative disclosure about leases in addition to quantitative disclosures previously required. As permitted, we adopted this ASU prospectively as of January 1, 2019 with no restatement of prior period financial statements. This ASU permits companies to elect certain practical expedients upon adoption, and at adoption we elected the package of practical expedients related to, among other things, lease classification (in which existing leases classified as operating leases under prior GAAP are classified as an operating lease under the new ASU, and existing leases classified as a capital lease under prior GAAP are classified as a finance lease under the new ASU), nonlease components (in which nonlease components associated with a lease and paid by us to the lessor, such as property taxes, insurance and maintenance, are treated as a lease component and considered part of minimum lease rental payments), and short-term leases (in which leases with an original maturity of 12 months or less are excluded from the recognition requirements of the new ASU). Upon adoption of this new ASU, at January 1, 2019 we recognized an aggregate right-of-use operating lease asset of \$35.1 million and a corresponding aggregate operating lease liability of \$34.5 million (there was no impact to the opening balance of retained earnings at January 1, 2019 as a result of adopting this new ASU). See Notes 1 and 7.

*Pending Adoption*

In December 2019, The Financial Accounting Standards Board issued ASU 2019-12, *Simplifying the Accounting for Income Taxes*, which changes the accounting for certain income tax transactions and reduces complexity in accounting for income taxes in certain areas. The ASU introduces new guidance including providing a policy election for an entity to not allocate consolidated current and deferred tax expense when a member of a consolidated tax return is not subject to income tax in its separate financial statements and is a disregarded entity by the taxing authority; and providing guidance to evaluate whether a step-up in tax basis of goodwill relates to a business combination in which book goodwill was recognized or a separate transaction. The ASU also changes existing guidance in a number of areas, including: the method of making an intraperiod allocation of total income tax expense if there is a loss in continuing operations and gains outside of continuing operations; determining when a deferred tax liability is recognized after an investor in a non-U.S. entity transitions to or from the equity method of accounting; accounting for tax law changes and year-to-date losses in interim periods; and determining how to apply the income tax guidance to franchise taxes that are partially based on income. The amendments in ASU 2019-12 are effective for us beginning in the first quarter of 2021, with early adoption permitted. We expect to adopt this ASU in the first quarter of 2020 and we do not expect the adoption to have a material effect on our Consolidated Financial Statements.

**Note 21—Quarterly results of operations (unaudited):**

	<b>Quarter ended</b>			
	<b>March 31</b>	<b>June 30</b>	<b>Sept. 30</b>	<b>Dec. 31</b>
	<b>(In millions, except per share data)</b>			
<b>Year ended December 31, 2018</b>				
Net sales	\$ 466.0	\$ 510.2	\$ 455.2	\$ 388.7
Gross margin	185.3	184.0	132.7	107.2
Operating income	118.8	130.0	69.2	52.7
Net income from continuing operations	70.2	20.0	148.3	28.4
Amounts attributable to Valhi stockholders:				
Income from continuing operations	\$ 51.7	\$ 11.3	\$ 142.8	\$ 22.3
Income (loss) from discontinued operations	37.6	.4	.7	(4.6)
Net income	<u>\$ 89.3</u>	<u>\$ 11.7</u>	<u>\$ 143.5</u>	<u>\$ 17.7</u>
Earnings per share:				
Income from continuing operations	\$ .15	\$ .03	\$ .42	\$ .07
Income (loss) from discontinued operations	.11	-	-	(.01)
Basic and diluted income per share	<u>\$ .26</u>	<u>\$ .03</u>	<u>\$ .42</u>	<u>\$ .06</u>
<b>Year ended December 31, 2019</b>				
Net sales	\$ 479.6	\$ 528.6	\$ 475.2	\$ 414.1
Gross margin	121.8	123.2	98.4	91.2
Operating income	60.4	65.9	41.4	25.0
Net income from continuing operations	28.4	18.2	17.2	14.4
Amounts attributable to Valhi stockholders:				
Net income	<u>\$ 18.2</u>	<u>\$ 7.1</u>	<u>\$ 13.1</u>	<u>\$ 10.8</u>
Basic and diluted income per share	<u>\$ .05</u>	<u>\$ .02</u>	<u>\$ .04</u>	<u>\$ .03</u>

We recognized the following amounts during 2018:

- a pre-tax gain of \$12.5 million in the first quarter related to the sale of land not used in our operations (see Note 13);
- a pre-tax charge of \$62 million related to the litigation settlement expense recognized in the second quarter (see Note 18);
- a non-cash deferred income tax benefit of \$112 million in the third quarter related to a change in the deferred income tax liability related to our investment in Kronos as a result of the 2017 Tax Act (see Note 14);
- a pre-tax gain of \$12.5 related to a securities transaction gain recognized in the third quarter related to the sale of our interest in Amalgamated Sugar Company LLC (see Note 6);
- a current cash income tax expense of \$4.0 million in the fourth quarter of 2018 related to GILTI (see Note 14).

We recognized the following amounts during 2019:

- a pre-tax charge of \$19.3 million related to a litigation settlement expense primarily recognized in the second quarter (see Note 18);
- pre-tax income from tax increment infrastructure reimbursement of \$8.8 million primarily recognized in the second quarter (see Note 7);
- pre-tax insurance recoveries of \$7.7 million primarily related to a single insurance recovery settlement recognized in the second quarter (see Note 13);
- a pre-tax gain on sale of land of \$4.4 million in the third quarter (see Note 13); and
- a pre-tax gain of \$3.0 million related to NL's sale of its insurance and risk management business recognized in the fourth quarter (see Note 13).

The sum of the quarterly per share amounts may not equal the annual per share amounts due to relative changes in the weighted average number of shares used in the per share computations.

EXHIBIT 21.1

SUBSIDIARIES OF THE REGISTRANT

Name of Corporation	Jurisdiction of Incorporation or Organization	% of Voting Securities Held at December 31, 2019 (1)
ASC Holdings, Inc.	Utah	100%
Kronos Worldwide, Inc. (2)	Delaware	50%
NL Industries, Inc. (2), (3), (4)	New Jersey	83%
CompX International Inc. (4)	Delaware	87%
Tremont LLC	Delaware	100%
TRECO LLC	Nevada	100%
Basic Management, Inc.	Nevada	63%
Basic Water Company	Nevada	100%
Basic Water Company SPE LLC	Nevada	100%
Basic Environmental Company LLC	Nevada	100%
Basic Power Company	Nevada	100%
Basic Remediation Company LLC	Nevada	100%
Basic Land Company	Nevada	100%
The LandWell Company LP (5)	Delaware	50%
Henderson Interchange Sign LLC	Nevada	100%
TRE Holding Corporation	Delaware	100%
TRE Management Company	Delaware	100%
Tall Pines Insurance Company	Vermont	100%
Medite Corporation	Delaware	100%

- (1) Held by the Registrant or the indicated subsidiary of the Registrant.
- (2) Subsidiaries of Kronos are incorporated by reference to Exhibit 21.1 of Kronos' Annual Report on Form 10-K for the year ended December 31, 2018 (File No. 333-100047). NL owns an additional 30% of Kronos directly.
- (3) Subsidiaries of NL are incorporated by reference to Exhibit 21.1 of NL's Annual Report on Form 10-K for the year ended December 31, 2018 (File No. 1-640).
- (4) Subsidiaries of CompX are incorporated by reference to Exhibit 21.1 of CompX's Annual Report on Form 10-K for the year ended December 31, 2018 (File No. 1-13905).
- (5) TRECO LLC owns an additional 27% of The LandWell Company LP directly.



[THIS PAGE INTENTIONALLY LEFT BLANK]

[THIS PAGE INTENTIONALLY LEFT BLANK]



**Valhi, Inc.**

Three Lincoln Centre  
5430 LBJ Freeway, Suite 1700  
Dallas, TX 75240-2620  
(972) 233-1700